

Introduction to Mechanical Design and Manufacturing

INTRODUCTION TO MECHANICAL DESIGN AND MANUFACTURING

DAVID JENSEN



Introduction to Mechanical Design and Manufacturing Copyright © by David Jensen is licensed under a Creative Commons Attribution-NonCommercial 4.0 International License, except where otherwise noted.

CONTENTS

Introduction	1
--------------	---

Part I. Product Design from a Mechanical Engineering Perspective

Three Views of Product Design	7
Typical Types of Product Design	10
Design Process Overview	12
A Case Study - A Ball Point Pen	15
Why Integrate Design and Manufacturing?	20
Wrap up - Product Design from a Mechanical Engineering Perspective	21

Part II. Design Primitives and Fundamentals

Design Drivers - What is a “Good” solution in the Product Design Context	25
Tangible and Intangible Properties of Product Design	30
Case Study - Design Vision	34
Models – The Language of Design	39
Wrap up - Design Primitives and Fundamentals	44

Part III. Design Teams and Design Project Management

Identify and Define a Product Design Opportunity	47
Team-Based Design Decision Making	51
Individual Design Decision Making	54

Project Timeline Management	57
Project Team Management	60
Wrap up - Design Teams and Design Project Management	64

Part IV. Defining and Managing Design Requirements

Who are the Stakeholders and What do they Want?	67
Methods to Gather Stakeholder Needs	69
Checklist for Generating Requirements	71
Engineering Requirements	79
House of Quality Tool for Needs and Specification Management	82
Wrap Up - Defining and Managing Design Requirements	85

Part V. Conceptual Design Process and Tool

Creativity Techniques	89
Tools for Supporting Creative Design Solutioning	93
Functional Analysis	101
Morphological Chart	106
Decision and Selection	113
Develop Prototypes to Further Define Concepts	121
Wrap Up - Conceptual Design and Tools	131

Part VI. Systematic and Iterative Process of Embodiment Design

Overview of the Design Embodiment Process	135
Constraints	136
Configuration and Architecture	137

Connections and Interfaces	139
Define Components	142
Iterate and Refine	144
Wrap Up - Detailed Design	145

Part VII. Specification of Standard Mechanical Components

Generalized Process for Standard Specifications	149
Fasteners	154
Pins and Joints	156
Bearings	159
Mechanical Springs	161
Motors and Controllers	166
Wrap Up - Common Mechanical Component Specification	175

Part VIII. Assemblies for Motion and Power Delivery

Machines and the Control of Work	179
Linkages and Mechanisms	181
Motion and Control of Mechanisms	189
Mechanism Synthesis	196
Mechanism Posture and Position Analysis	199
Mechanism Force, Velocity and Acceleration Analysis	205
Cam Systems and Cam Design	210
Gearing Systems	214
Pulleys and Belts and Chain and Sprocket Systems	218
Wrap Up - Assemblies for Motion and Power	221

Part IX. Product Design Prototyping

Types of Prototypes and Prototyping Strategy	225
Prototyping Methods and Technologies	228
Building and Testing Prototypes	232
Wrap-Up - Prototyping Product Concepts	234

Part X. Design for Manufacturing and Assembly Principles and Methods

Design for Manufacturing Principles	237
Design for Assembly Principles	239
Introduction to Geometric Dimensions and Tolerances	243
Fits and Tolerances	248
Wrap-Up - Design for Manufacturing and Assembly	253

Part XI. Manufacturing - Casting and Molding Process

Metal Casting Fundamentals and Terms	257
Types of Casting Process and Excepted Tolerances	259
Multiple Use Casting and Molds	262
Single Use Molds	266
Powder Metal Processes	270
Design for Casting and Molding Principles and Best Practices	272

Part XII. Manufacturing - Forming and Shaping Processes

Metal Forming Process Types and Tolerances	277
Rolling	279

Drawing	281
Forging	282
Extrusion	284
Sheet Metal Work	286
Design for Forming Principles and Practices	290

Part XIII. Manufacturing - Machining Processes

Types of Cutting and Machining Process and Tolerances	295
Milling	299
Drilling, Boring, Broaching, and Tapping	301
Turning	305
Grinding and Polish	306
Finishing Treatment Processes	308
Design for Machining Processes	314

Part XIV. Manufacturing - Joining Processes

Welding Methods	319
Brazing and Soldering	322

Part XV. Manufacturing - Plastic Processes

Plastic Materials	327
Molding	329
Plastic Extrusion	334
Plastic 3D Printing at Large Scale	335
Machining	336

Design for Plastic Manufacturing

337

Part XVI. Taking the Next Steps

Preliminary Patent Applications

341

Professional Licensure and Consulting

343

Final Thoughts

345

This book is an introduction to product design and manufacturing, with a focus on the mechanical engineering aspects. It covers the principles, methods, tools and techniques that are used to create, analyze, optimize and manufacture products that meet the needs and wants of customers. The book is intended for students, educators, practitioners and researchers who are interested in learning about the theory and practice of product design and manufacturing. The book is open access, which means that it is freely available online for anyone to read, download, share and reuse. The book aims to provide a comprehensive and up-to-date overview of the current state of the art in product design and manufacturing, as well as to inspire new ideas and innovations.

This book builds on the efforts of many individuals and existing content. You will find additional resources and other open access content linked throughout the text.

Are you using this textbook in your class? Let me know!

PART I

PRODUCT DESIGN FROM A MECHANICAL ENGINEERING PERSPECTIVE

Learning Objectives

This first part summarizes the overall perspective and steps for product design and manufacturing. By the end of this part readers should be able to:

- Describe the systematic design process.
- Understand and explain what drives the design decision-making process.
- Describe how design problems differ from other types of engineering analysis tasks.

Introduction

One of the most distinctive features of human beings is their ability to create and transform the world around them. From the earliest tools and artworks to the most advanced technologies and innovations, humans have always been driven by a desire to make things that serve their needs, express their ideas, and shape their environment. This creative impulse is part of human nature, and it reflects our innate curiosity, intelligence, and imagination. Making things is not only a practical activity, but also a way of exploring our identity, culture, and values.

So why are you here? What is the point of taking a course and learning about an activity you have already been doing most of your life from building with Legos to organizing and making your family dinner? Yes, as humans, we are makers. But as designers, we are makers who make things well... at least... when it works out. As we will see, that is not always the case.

Designing is an innate ability that humans possess, as we constantly create and improve our surroundings to suit our needs and desires. However, this does not mean that we can design anything without guidance or knowledge. Taking a course and learning about product design can help us develop our skills, understand the principles and methods of design, and apply them to various contexts and domains. Product design is not just about making things look good or function well, but also about solving problems, meeting user needs, and creating value for society. By learning from experts and peers, we can gain insights, feedback, and inspiration that can enhance our design process and outcomes.

As engineers, we have a specific perspective on the phenomena of designing that we will discuss in detail. But it is important to understand that, for engineers, designing is more than making. Engineers are sworn to a code of ethics, among which is usually that we use our knowledge and skill for the betterment of humanity. Therefore, we are bound by our honor to ensure we are using the best of our knowledge and skills to design products and systems that benefit humanity.

Ethics in Engineering & Engineering Groups – ASME

The term *design* can be understood as both a noun and a verb. As a noun, design refers to the outcome of a creative process, such as a product, a service, or a system. From the object perspective, the term design implies more than the physical object. This noun sense also conveys the information content represented by the object. Consider a key for a door lock. The *design* of the key includes a specific shape and material. The shape contains information about the lock (the position the tumblers need to engage the locking mechanism) and the material represents information about how the designers expected the key to be used. One aspect of ***Design Thinking*** is understanding that every made product or system can be understood as the summation of all the decisions that lead to it. A designer is responsible for making many of those decisions.

The act of making those decisions is the activity or verb form of the term design. As a verb, design refers to the activity of creating something, that is, a way of thinking. Most of the study of design in this text is focused on this activity perspective. We will focus on tools, methods, and best practices to help designers make decisions or, in other words, *to design*. Finally, design as a verb can also be a way of thinking and problem-solving that involves empathy, creativity, and iteration. This is broadly referred to as ***Design Thinking***.

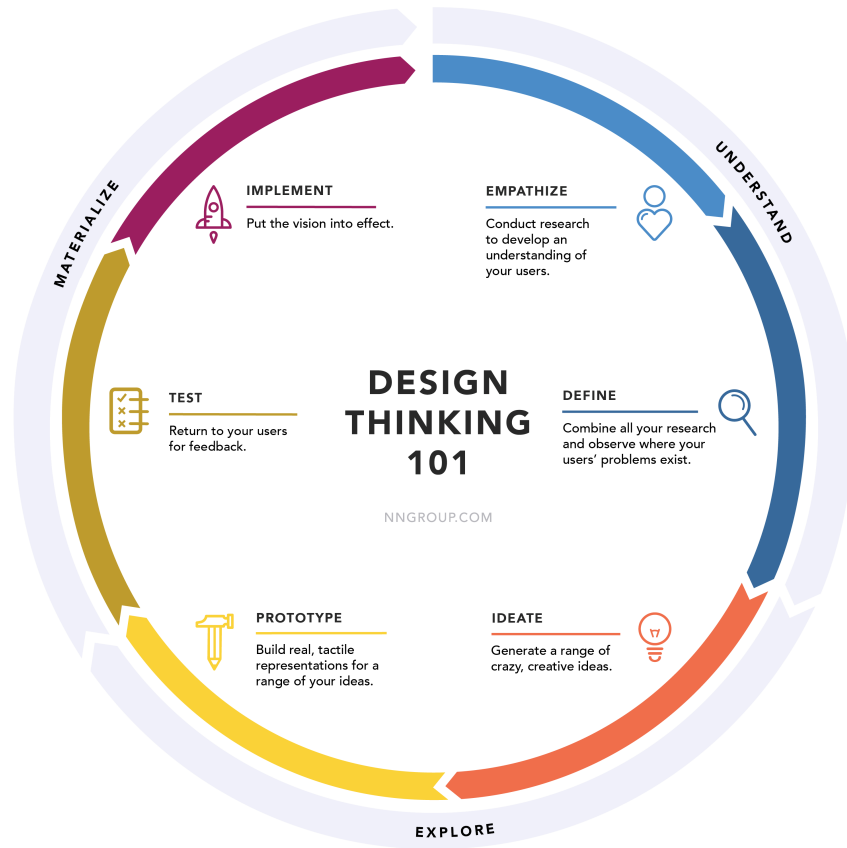

https://media.nngroup.com/media/editor/2016/07/29/designthinking_illustration_final-01-01.png

THREE VIEWS OF PRODUCT DESIGN

Technical – Aesthetic – Economic

The term design can have different meanings and interpretations depending on the context and the discipline. For example, graphic design is concerned with the visual aspects of a product, such as colors, fonts, images, and layouts. Product structure design is focused on the physical components and functions of a product, such as materials, shapes, mechanisms, and interfaces. Other types of design include service design, interaction design, user experience design, and system design. All these design disciplines share some common principles and methods, but they also have their own goals and challenges. Therefore, it is important to understand the scope and nature of each design domain before engaging in a product development process.

Designing is a complex and multifaceted phenomenon that can be understood from different perspectives. One perspective is aesthetic, which focuses on the form, appearance, and style of a product. Another perspective is technical, which deals with the functionality, performance, and reliability of a product. A third perspective is economic or entrepreneurial, which considers the marketability, and profitability of a product. These perspectives are different yet have important interactions and relationships. For example, a product that is aesthetically pleasing may attract more customers, but it also needs to be technically sound and economically viable. A product that is technically innovative may offer new benefits, but it also needs to be aesthetically appealing and economically feasible. A product that is economically successful may generate more revenue, but it also needs to be aesthetically satisfying and technically reliable. Therefore, design requires a balance and integration of these perspectives to create products that meet the needs and expectations of users and stakeholders.

The most important misconception to address right off the bat is what domain or perspective you should have. The target audience for this text focuses on the technical domain. There is often an underlying anxiety with respect to the other domains. ***Siloing*** is a term used when you or your team focus only on one aspect of the design, such as the technical, and trust that others will handle the economic and aesthetic perspectives. You may not be getting a degree in business, but without understanding the economic drivers, your product design may devolve into non-value adding activities. You may or may not consider yourself artistic. However, you can learn and apply principles to develop elegant and functional products. In short, individuals will have specific education, skills, and experience in a particular domain. However, great designers will continuously consider perspectives outside their own throughout the design process.

The Technical Perspective of Product Design

This textbook will focus on the technical perspective of product design. Let's start with a detailed definition.

Engineering Design is a systematic and iterative process(1) of decision-making(2) to develop(3) a product, service, process, or system(4) to satisfy stakeholder needs.

Let's dig into this definition a little deeper with the numbers shown above:

1. Understand that the activity of designing involves moving through systematic stages as well as iterations within and between those stages is critical. There is a natural human desire not to revisit a decision once it has been made. However, changes will occur, and knowledge gained from the design process will require revisiting some decisions. However, for design work to be successful it must be moving forward towards completion.
2. Designing is not the same thing as tinkering. Design engineers are not hired to "just try stuff until it works". Your education and experience are valuable because you will be using them to make decisions. You also have the honorable and grave responsibility for those decisions as the products we make affect human lives.
3. Various stages of designing are often enjoyable for many people. Creative thinking and problem solving, "eureka moments", and detailed modeling and analytical thinking can be very satisfying. However, designing needs to lead to one of two outcomes: either successful designs or valuable learning experiences.
4. There are many different technical domains in design. Often, there is a significant overlap in methods and goals. However, there are specific tools and practices that are most effective in certain domains. Not all of the tools and techniques in architectural design will be applicable to chemical process design. However, there is often much that can be learned by studying how others design. Always keep an open and learning mindset. This text will focus on techniques and tools that are most effective in the development of electromechanical products.

To misquote Voltaire: "Perfection is the enemy of good enough." The end goal of design is satisfaction of needs. There will always be tradeoffs. Thus, a successful design is one that meets those needs. Most of the time, there is no way of knowing what the "best" solution will be in the beginning. If any design decision cannot ultimately be traced back to a stakeholder's needs, that decision should be suspect.

There is a likely untrue story of Thomas Edison trying and failing 10,000 times to invent the

light bulb. While this sounds encouraging, it is not designing (nor what actually happened in the light bulb development process). <http://uncommoncontent.blogspot.com/2015/05/how-many-times-did-edison-fail-in.html>).

TYPICAL TYPES OF PRODUCT DESIGN

If product design is a decision-centric process, it can be helpful to consider what types of decisions need to be made. The overall type of design activity strongly influences the type of decision a designer will need to make. While designing a product, engineers will often utilize many of the following types of design activities. However, it is often the case that one primary type of activity dominates. The specific order sequence of decisions, the type of tools and best practices, and some of the goals will be different depending on the type of design activity.

Selection Design

Selection design is a type of product design that involves choosing and combining components from existing catalogs, rather than creating new ones from scratch. Selection design can reduce the cost and time of product development, as well as ensure compatibility and reliability of the components. However, selection design also requires careful analysis of the requirements and constraints of the product, as well as evaluation of the available components in terms of their performance, quality, and cost. An example of selection design is designing a bicycle by selecting and assembling different parts from various suppliers, such as the frame, wheels, brakes, gears, and so on.

Variant Design

Variant design is a product design method that involves choosing the best options from a set of alternative sub-assemblies to meet the customer's requirements. Variant design allows the designer to create different versions of a product that share some common features but differ in others. For example, when building a custom desktop computer, the designer can use variant design to select the best combination of components such as CPU, RAM, GPU, motherboard, storage, etc. based on the customer's needs and budget. Variant design can reduce the design time and cost by reusing existing sub-assemblies and avoiding unnecessary changes.

Assembly or Packaging Design

Assembly or packaging design is a type of product design that involves the integration of the components specifically to meet high level functions. For example, in a smartphone, the assembly or packaging design

determines how the processor, memory, battery, camera, and other components are arranged and connected inside the phone case. Assembly or packaging design can affect the performance, reliability, cost, and manufacturability of the product. Therefore, it requires careful consideration of various factors such as the materials, geometry, interfaces, connections, and environmental conditions of the components and the product as a whole. Assembly or packaging design also involves trade-offs between competing objectives such as minimizing weight, maximizing strength, optimizing heat transfer, and reducing noise and vibration.

Novel Design

Novel design is a term used to describe a design that is original and not primarily derived from an existing solution. Novel design often involves technology push, meaning that a new technology is developed or adapted to meet the needs and expectations of the stakeholders. Technology push can create new opportunities but faces challenges such as aspects of feasibility, usability and acceptability are typically unknown beforehand. A novel design should balance the benefits and risks of technology push with the requirements and preferences of the users and other stakeholders. Often, the first company to introduce the novel design has an advantage.

Redesign

Redesign is a type of design that builds on existing solutions rather than creating new ones from scratch. It is often driven by market-pull, which means that there is a demand or an opportunity for improvement in the current market. For example, a redesign project might be initiated when there are changes in the market conditions, such as new competitors, customer preferences, or regulations. Alternatively, a redesign project might be triggered by the identification of a new stakeholder or an unmet need that was not addressed by the original solution. Redesign involves analyzing the existing solution, identifying its strengths and weaknesses, and proposing modifications or enhancements that can increase its value, usability, or performance.

DESIGN PROCESS OVERVIEW

In this course we will utilize a “systematic” description of the design process. There are several reasons for using this as a model but before getting into those justifications, it is important to note that there are actually many paradigms of engineering design. The way you perceive the design process affects how, when and what type of decisions you make. For an example of a very different paradigm from systematic design, look up C-K theory. Additionally, there are many different variations of the systematic process that help designers focus on one aspect or another. For example, User-Centered design is a popular paradigm that focuses designers’ empathy to satisfy the needs of users or customers.

So why are focusing on the systematic design process?

1. The systematic process is what is most common in industrial practice.
2. The systematic nature is conducive to the structure of an academic course with stages, assessments, and regular deliverables.

5 Stages of Product Design

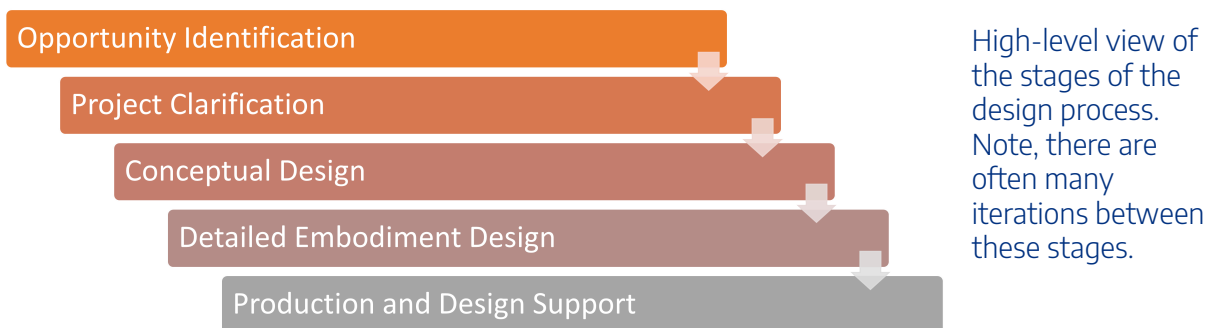

At the most basic form, a systematic design process describes the process of moving between four phases:

1. Opportunity Identification
2. Project Clarification
3. Conceptual Design
4. Embodiment and Detail Design
5. Design Support

Opportunity Identification

The first phase of product design is identifying and clarifying a project opportunity. This phase involves finding a problem or need that can be solved by designing a new or improved product. The problem or need may come from various sources, such as customers, competitors, market trends, regulations, or technological developments. The product designer must research the problem or need and define it clearly and precisely.

Identifying and clarifying a project opportunity also requires evaluating the feasibility and desirability of the potential product. The product designer must consider the technical, economic, social, and environmental aspects of the product and how they affect its performance, cost, quality, safety, and sustainability. This stage often also includes the identification of stakeholders. Stakeholders are those with an interest in the outcome of the design process. Those can include your company, government regulators, distribution and sales organizations, customers, users, maintenance personnel or organizations, and others depending on the domain. Failing to identify an important stakeholder at this stage can lead to making the wrong product for the wrong stakeholder.

Project Clarification

The second phase of engineering design is project clarification. In this phase, the engineer defines the problem and its scope more clearly by determining what these stakeholders need from the design, such as functionality, performance, reliability, safety, cost, aesthetics, etc. These needs are then prioritized and translated into measurable technical targets that can be used to evaluate and compare different design concepts in the next phase. Project clarification is a critical step in engineering design because it ensures that the design meets the expectations and requirements of the intended users and customers, as well as other social, environmental, ethical, and legal factors. The project clarification stage is when we define the evaluation criteria to assess if our design is successful. Successful designs are those that satisfy stakeholder needs by achieving the identified targets within economic, manufacturability, ethical and other constraints.

Conceptual Design

The third phase of engineering design is conceptual design. In this phase, the problem is defined by identifying the required functions. The functions are the actions or tasks that the product or system must perform to satisfy the customer needs and specifications.

Conceptual design involves generating one or more solution principles for each function. The next step of conceptual design is to select the concept for each function and combine them into an overall product or system concept. This synthesis step should be done several times in order to develop a large potential pool of complete concepts. Finally, these complete concepts can be evaluated and a single or few concepts can move

forward towards detailed design. This evaluation is done by using various criteria such as stakeholder needs, design targets, concept screening, concept scoring, and decision matrices. The selected concept should meet or exceed the customer expectations and requirements, as well as be feasible, reliable, and cost-effective.

Embodiment and Detailed Design

The detailed stage of design is the fourth phase in the mechanical product design process, where the system architecture, assemblies and their arrangements are defined. This stage involves specifying the types of standard components and the material and geometry of custom-made components that will be used to realize the product functionality and performance. The Detailed stage of design requires careful analysis and evaluation of various design alternatives, trade-offs and constraints, as well as consideration of manufacturability, reliability, maintainability and cost aspects. The output of this stage is a complete set of detailed drawings, specifications and documentation that describe the product structure and characteristics.

Production and Support

The production and support stage is the fifth and final stage of product design. This stage involves defining the processes and methods for manufacturing and assembling the product. This may require testing and refining different prototypes until the product meets the desired specifications and quality standards. The production and support stage also includes providing ongoing maintenance and service for the product, as well as planning for its disposal or recycling at the end of its life cycle. This is important for minimizing the environmental impact of the product and promoting sustainability.

A CASE STUDY - A BALL POINT PEN

The following motivating example is from the Delft Design Guide.

Daalhuizen, Jaap. 2018. Delft Design Approach, Delft University of Technology.

Products are designed and made because of their functions. To design a product is to conceive of the use of the product and to find a suitable geometrical and physio-chemical form for the product and its parts, so that the intended function, or functions, can be fulfilled. Seen this way, the kernel of designing a product is reasoning from function to form and use. In order to understand the nature of product design one must understand the nature of that reasoning process. Therefore, by means of an example, we shall take a look at the relationships between the function, the properties, the form and the use of products.

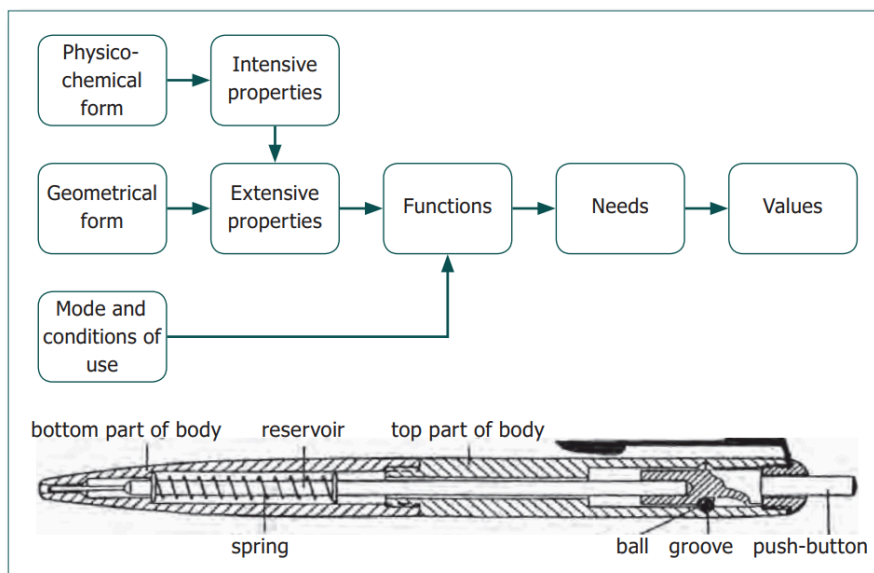

fig. 1.1 Model of reasoning by designers. (Roozenburg and Eekels, 1995)

Form:

Figure 1.1 shows a ballpoint pen. A ballpoint pen can be seen as an assembly of different parts.

Each part is defined by its form. By the form of a part, we mean the geometrical form (geometry or shape including size) as well as the physio-chemical form (the material).

Properties:

Due to their form, the parts have particular properties. Some of these properties depend on the physicochemical form only. These are called the *intensive properties*. Examples are the hardness of the writing ball, the density of the body and the viscosity of the ink. Other properties, the thing properties, are a result of the intensive properties plus the geometrical form. For example, the weight of the body of the pen depends on the density and its volume. Rigidity of the body parts and ink flow smoothness are other examples. These properties are called *the extensive properties*. Designers are particularly focused on the extensive properties, as they most directly determine the functioning of a product. By choosing for a material, a designer sets many intensive properties all at once so to say, both good and less desirable ones (steel is stiff, but it is heavy and rusts; aluminum is light and does not corrode but is less stiff). The art of designing is to give the product such a geometrical form that it has the desired extensive properties, given the intensive ones.

Function:

Due to its properties a product can perform functions. In our example: the function of a ballpoint pen is 'writing'. A function is the intended ability of a product to change something in the environment (including ourselves) of that product. Some process should run differently than it would without the product, e.g. a coffee mill changes beans into ground coffee, a chair prevents one from becoming tired, and a poster provides information (decreases uncertainty). Properties and functions have in common that they both say something about the behavior of things; they differ in that products have particular properties irrespective of the purposes of people. So, statements on properties are objectively true (or false). This is not so for functions. Functions express what a product is for, its purpose, and this depends on intentions, preference, objectives, goals and the like, of human beings. So different persons might see different things as the function of a product.

Needs and Values:

By fulfilling functions products may satisfy needs and realize values. For instance, 'writing' may

provide for a need to express oneself and thereby realize aesthetical or economical values. In figure 1.1 developing a product proceeds from right to left. The more to the right one starts the more open-ended the design process will be (ballpoints are by far not the only things that can help realizing aesthetical values). But often designers start from an initial idea about function(s) for a new product and for the remainder of this section we shall assume that this is the case.

The kernel of the design problem:

Now one can think up all sorts of functions and try to design a product for them, but will that product really behave as intended? Of course, the functioning of a product depends on its properties and hence on its geometrical and physio-chemical form. But there is more to it. For instance, a ballpoint will write only if being used as anticipated by its designers: one must hold the pen in a certain way, one can write only on a more or less horizontal surface (on vertical surfaces ballpoints do not work) and the air pressure in the environment should neither be too low nor too high (in space capsules, normal ballpoints do not work). So not only the form but also the mode and conditions of use determine how a product will actually function. Said differently: *the context* of use counts as much as the product itself and therefore designers should equally pay attention to both of them. In many cases, especially for innovative products, the mode and conditions of use are not given facts for the designer but are thought up – together with the form of the product – and hence form an essential part of the design. So, designing a product involves more than designing the material thing; it also includes the design of its use. Figure 1.1 shows how the functioning of a product depends on its form and its use. The arrows indicate causal relations. This means that if you know the geometrical and physio-chemical form of a product (i.e. the design of the ballpoint) you can in principle predict its properties. And if you also know in which environment and how the product will be used you can predict whether it will work or not. This kind of reasoning is often called *analysis*. For designers, analysis is an important form of reasoning, because it is the basis for all sorts of simulation. But for designers the essential mode of reasoning is to reason from function to form. Before something can be analyzed, designers should first think up the form and its use as a possibility, and this in such a way that, if users act in accordance with the usage instructions, the intended function is realized. This is the kernel of the design activity. Reasoning from function to form is usually called *synthesis*. The descriptions represented in whatever manner of the form and the use of the product make up the design. Now there is an important difference between these two modes of reasoning. The reasoning from form and use to functioning – ‘analysis’ – is based on deduction. Deduction is a conclusive form of reasoning, because in principle there is only one

answer: the product has or has not the required properties and will or will not function as intended. But we cannot infer conclusively the geometrical and physio-chemical form from the function, even if we would know everything about the laws of nature that govern the required behavior of the product. And in principle there are always different possibilities.

Here lies the challenge for designers, for in designing the most decisive step is not to predict the properties of a product already thought up, but the preceding step of conceiving of the form and use of that product. In a rather poignant contrast to this stands the fact that for the transition from form and use to function much scientific knowledge and methods are available, while the transition of function to form depends largely on the creative abilities and insight of the designer. This does not mean that scientific and technical knowledge does not play a part. Causal models indicate the direction in which main choices can be made (choice of material, choice of shapes, choice of one or more key dimensions). Yet these models never lead to an unambiguous answer. The number of possible solutions to a design problem is in principle even innumerable. The foregoing explains why in product design intuition and creativity have an indispensable role to play. Notwithstanding the importance of scientific knowledge, systematic approaches and modern possibilities for simulation, without intuition and creativity design processes would come to a standstill. A design cannot be deduced from a description of a problem, nor from a function or a performance specification. A design must be created in the true sense of the word. Knowledge only is not sufficient to design a product. Producing new ideas for products requires intuition and creativity, not only in the domain of product design but also in all design domains.

A Multidisciplinary Approach:

In the preceding analysis much has been left out in order to highlight the kernel of designing. In reality product designers have to deal with a variety of interests and stakeholders in the design process. Therefore, in addition to the function(s) many other factors must be considered when designing a product. Consumers look upon a product as something to be bought and used. To the design engineer it is a technical-physical system that has to function efficiently and reliably. Production engineers have to manufacture it, often in large numbers, preferably fast, cheaply, accurately and with the lowest possible number of faults. A marketer considers it a commodity with added value, something that people are prepared to buy. Entrepreneurs invest in new products and count on an attractive return. People that are not directly involved may see above all the reverse side of the coin: the undesirable and often even harmful side effects of production and use. To every point of view, there are corresponding requirements that must be

taken into account. Product design, therefore, demands a multidisciplinary approach. Which disciplines have to contribute largely depends on the characteristics of the product to be developed, but engineering design, industrial design, ergonomics, marketing and innovation management are nearly always involved.

Reference: Roozenburg, N. and Eekels, J. (1995) Product Design: Fundamentals and Methods, Chichester: Wiley, 1995, pp. 53-81

WHY INTEGRATE DESIGN AND MANUFACTURING?

There are many great books, videos and resources that cover concepts and best practices for the design of products. The same can be said of resources to understand common manufacturing and assembly practices. However, it is often difficult to find these in a single location. That is the main objective of this text. As a mechanical engineer, you should have some exposure to the product and system design processes and common tools. However, this resource alone will not fully prepare you to be a design engineer. Additionally, you may find yourself working the manufacturing domain. This text will provide a reasonable background on many common manufacturing methods and best practices. However, you will not fully be prepared to work as a manufacturing engineer and will need to learn a lot more about specific processes and tools.

Ultimately, this text is a jumping off resource with the intent to point you towards your own quest of continuous improvement. It is up to you to decide what type of engineer you want to be.

WRAP UP - PRODUCT DESIGN FROM A MECHANICAL ENGINEERING PERSPECTIVE

Key Concepts and Terms

- Aesthetic, Economic, and Technical perspectives of product design
- Characteristic types of design: Selection, Variant, Assembly/Packaging, Novel, Redesign
- The systematic design process: Opportunity Identification, Project Clarification, Conceptual Design, Detail or Embodiment Design, Production and Support
- The nature of design problems: Open-ended, multiple possible solutions, and a focus on stakeholder satisfaction

Chapter Questions



An interactive H5P element has been excluded from this version of the text. You can view it online here:

<https://uark.pressbooks.pub/mechanicaldesign/?p=272#h5p-1>

PART II

DESIGN PRIMITIVES AND FUNDAMENTALS

Learning Objectives

This part discusses the fundamental concepts and terms related to the design process. After this part readers will be able to:

- Understand the concept of satisfying requirements for concept evaluation.
- Define the tangible and intangible properties of product concept.
- Develop a vision for a product and understand how to communicate that vision.

Designing is not Problem Solving... but it involves a lot of it!

Problem solving is the process of finding a solution to a given situation or challenge. One way to approach problem solving is to use the given-this-find-this formulation. This formulation consists of three parts: the given information, the desired information, and the constraints or criteria. For example, designing a chair will require defining dimensions and materials. Given the material properties and a maximum load, the minimum thickness of the chair material can be found to satisfy a strength or deflection constraint. This type of problem solving is very common in the engineering curriculum and most are well familiar with it.

Another common method for solving problems is to use heuristics. Heuristics are rules of thumb or shortcuts that help simplify the problem and guide the search for a solution. For example, a heuristic for the chair design might include typical thickness per material type. Using a heuristic like this might result in getting an approximate and useful solution but not defining an exact geometry. Heuristics are not guaranteed to find

the optimal solution, but they can help reduce the complexity and time of problem solving. Another form of heuristics is pattern matching. Many students have experience using homework problems or example problems to study for or complete exams. The same pattern matching can be used in problem solving in design that are similar in domain or solution principle.

However, there is a distinction between typical engineering problem solving and engineering design. One of the main distinctions between problem solving in engineering and design work in engineering is the degree of uncertainty and ambiguity involved in the process. Problem solving in engineering typically involves applying well-established methods and techniques to clearly defined problems with known parameters and constraints. Design work in engineering, on the other hand, involves dealing with ill-structured problems that have multiple possible solutions and criteria for evaluation. Design work in engineering requires more creativity, innovation and iteration than problem solving in engineering.

One of the challenges of product design is that design problems are often ill-structured or ill-defined. This means that there is no clear and definitive statement of what the problem is, what the goals are, what the constraints are, or what the criteria for success are. Ill-structured problems require designers to explore, frame, and refine the problem space as well as the solution space. They also require designers to deal with uncertainty, ambiguity, and complexity. Ill-structured problems are common in product design because products are influenced by many factors, such as user needs, market trends, technological opportunities, social and environmental impacts, and competitive forces. Therefore, product designers need to adopt a flexible and iterative approach that allows them to learn from feedback, experiment with alternatives, and adapt to changing conditions.

One way to describe the difference is that a design problem is like the given-this-find-this problem solving formulation except that the givens, the constraints, and the objectives change and are redefined throughout the process. This leads to an understandable frustrating question: If the problem continuously changes, how do we know when we have a “good” design or solution?

DESIGN DRIVERS - WHAT IS A "GOOD" SOLUTION IN THE PRODUCT DESIGN CONTEXT

Good Enough

One of the key challenges in product design is how to make optimal decisions that balance the needs and preferences of the users, the constraints and resources of the project, and the goals and vision of the stakeholders. However, finding the optimal solution is often impossible or impractical, as it would require exploring all possible alternatives and evaluating them against multiple criteria. This is where the concept of *satisficing* comes in handy. Satisficing is a term coined by the economist and Nobel laureate Herbert Simon, who argued that human decision makers often settle for satisfactory solutions rather than optimal ones, due to their limited information, time, and cognitive abilities. In product design, satisficing means choosing a design option that meets a minimum level of acceptability or adequacy, rather than searching for the best possible option. Satisficing can help designers avoid analysis paralysis, reduce uncertainty and risk, and speed up the design process. However, satisficing also has some drawbacks, such as missing out on potentially better solutions, compromising on quality or innovation, and settling for suboptimal outcomes. Therefore, satisficing should be used with caution and judgment, and not as an excuse for laziness or mediocrity.

There are three high-level categories of satisficing for product design: Project Cost, Product Quality features, and Time to Market. These categories represent the main factors that influence the design decisions and outcomes of a product development process.

Project Cost

The project cost for product design is composed of different parts, such as design, manufacturing, testing, marketing, and distribution. Each of these parts has a significant impact on the success of a design project, as they affect the quality, functionality, usability, and appeal of the product. However, among these parts, design is the most influential and critical one. Design decisions themselves have very little cost compared to other parts of the project, but they determine the requirements and specifications for the rest of the project. For example, a design decision about the shape, size, or material of a product can affect the manufacturing process, the testing methods, the marketing strategy, and the distribution channels.

Cost committed and cost incurred are two important concepts in the design and manufacturing process.

Cost committed refers to the amount of money that is allocated or obligated for a project or activity, regardless of whether it has been spent or not. Cost incurred refers to the actual expenditure of money for a project or activity, which may be less than or equal to the cost committed.

The difference between cost committed and cost incurred can have significant implications for the design and manufacturing process. For example, Figure # shows the relationship between cost committed and cost incurred over the different stages of the design and manufacturing process, from conceptual design to production. The figure shows that the majority of the cost of manufacturing is already committed at the end of the conceptual design stage, even though the actual cost incurred is still low. This means that any changes or modifications made after the conceptual design stage will have a limited impact on reducing the cost of manufacturing but may increase the cost incurred due to rework or delays. Therefore, it is important to make optimal decisions and trade-offs during the conceptual design stage, when the cost committed is still low and flexible, and avoid unnecessary changes or errors in later stages, when the cost committed is high and fixed.

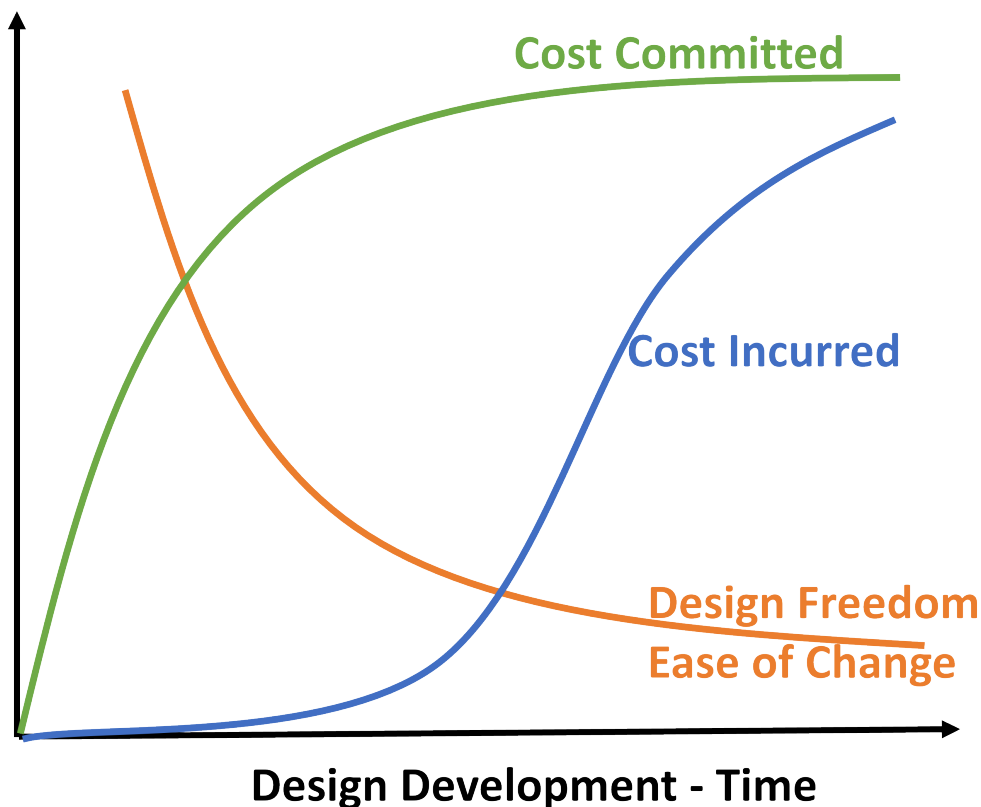

As a product is refined the cost of development increase while design freedom decreases.

Project Quality Features

A product affords a capability to a particular level of performance for a period of time. These three things

(capability, level of performance, and time period) can all be summarized as feature qualities. For example, a consumer might compare two vehicles based on safety. They might look at rollover resistance (a capability and a performance level) as well as a perceived reliability (how long it should continue to provide that performance). When designing a product there are design decisions that affect the quality of the features in the product. Further, the law of diminishing returns affects these choices. A cell phone that offers 1 terabyte of storage is not much different than a phone that offers 100 terabytes as both are well beyond what the typical consumer needs. The satisfactory quality of different features are not equal, that is, designers do not try and optimize every feature.

The **Kano model** is a framework for prioritizing features of a product based on the level of customer satisfaction they can bring. The Kano model was introduced by Noriaki Kano, a quality management professor at the Tokyo University of Science, in 1984. According to the Kano model, there are three types of features: basic, performance, and attractive. Basic features are the ones that customers expect and take for granted, such as the brakes of a car. They do not increase satisfaction if present, but they cause dissatisfaction if absent. Performance features are the ones that customers are aware of and can compare with competitors, such as the speed of a car. They increase satisfaction if present and decrease satisfaction if absent. Attractive features are the ones that customers do not expect and are pleasantly surprised by, such as a sunroof of a car. They increase satisfaction if present, but do not cause dissatisfaction if absent. The Kano model helps product managers and designers identify the optimal mix of features that can satisfy and delight customers while being feasible to implement.

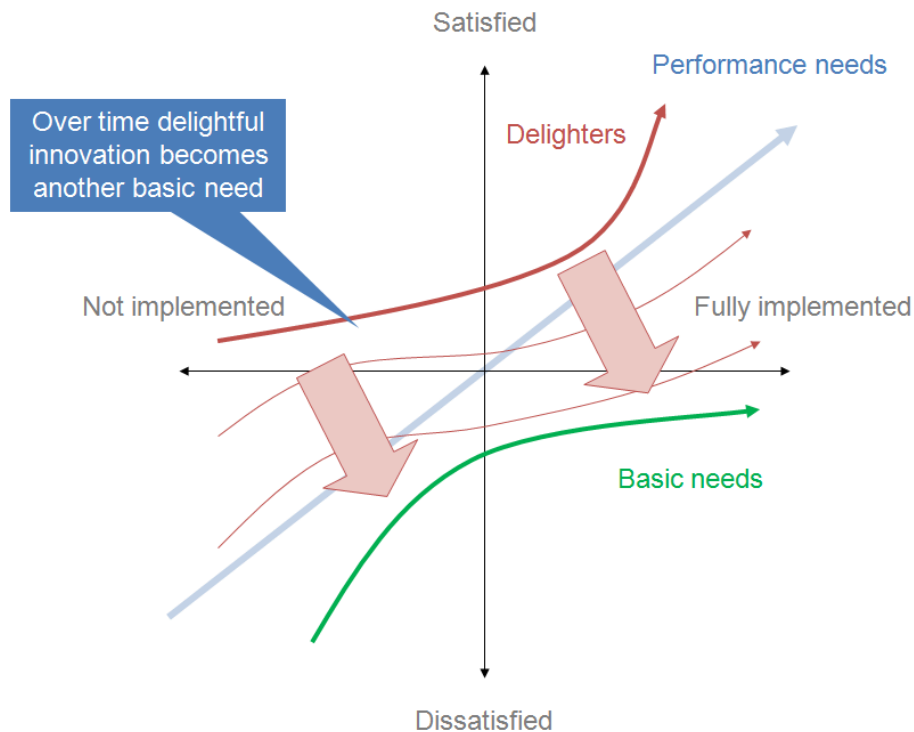

Kano Model – Source: https://commons.wikimedia.org/wiki/File:Kano_model_showing_transition_over_time.png

Time to Market

Time to market (TTM) is the measure of how long it takes your product team to usher an idea from inception to full public release. It gives you a way to conceptualize the amount of time required to complete various tasks throughout product development. In a competitive and fast-changing market, reducing TTM can provide significant advantages for your product, such as gaining a competitive edge, early revenue generation, and maximizing product lifecycle.

The performance evolution of a product over time can often be described by an S-curve, which shows how the product evolves from its introduction to its maturity and decline. One example of a product that follows an S-curve is the lightbulb. The lightbulb was invented in the late 19th century and improved gradually over time, reaching its peak performance in the mid-20th century. The lightbulb's performance is measured by its efficiency, which is the ratio of light output to power input. The efficiency of a lightbulb depends on the type of filament, the gas inside the bulb, and the shape and size of the bulb. New innovations drive the improvement in efficiency.

The S-curve of the lightbulb's efficiency shows that in the early stages, the rate of progress was slow, as inventors experimented with different materials and designs. As the technology became more mature, the rate of progress increased, as engineers optimized the existing solutions and discovered new ones. However, as the technology approached its physical limits, the rate of progress slowed down again, as further improvements became more difficult and costly. Without introduction of a completely new technology that utilizes different underlying physics (such as LEDs), the performance tends to follow this curve.

Depending on the maturity of a product, the time to market constraints differ. For a new type of product, the time to market constraints are longer, as it requires more research and development, testing, and validation. Being the first to enter the market is important, but only if the functionality is adequately implemented. Legal protections such as patents help provide companies time to develop new technology products.

For a mature product based on well-established technology, the time to market is shorter, as it relies on incremental innovations and adaptations. Taking a long time to make an incremental improvement will often result in losing out on market share as others will have provided that improvement (or comparative performance) earlier.

See the following article from Jason Crawford on how to understand innovation using the S-curve model.

[Teasing apart the S-curves](#)

These three categories (Cost, Quality of Features, and Time to Market) define and constrain most of the product design decisions. Further, they interact with each other. Spending more time to make improvements in quality increases cost and obviously extends the time to market. Shorter time to market goals may lead to selecting more costly manufacturing choices, thus reducing the value of more market share. Therefore, we define a "good design" as one which satisfies our cost, quality and time frame constraints.

TANGIBLE AND INTANGIBLE PROPERTIES OF PRODUCT DESIGN

What makes up a “Design?”

A product design (*noun*) includes aspects that are physical or tangible and easily observed as well as characteristics that are inferred. The overall product look, what components are used and their sizes and materials are usually easily observable. However, the purpose of each component, the justification for why it was manufactured in a certain way, and the overall vision or strategy of the product producer must be inferred using good engineering analysis. Consider *reverse engineering*. In reverse engineering, an existing product performance and physical features are measured. However, simply knowing all the dimensions of every part in a new car doesn't enable someone to make an exact copy of that car. The hard work of reverse engineering is understanding the intangibles. What are the functions, why did the designers choose certain dimensions, materials, and processes, etc.? Answer these questions requires detailed analysis and the end result is often an answer with some underlying uncertainty. In a *forward design*, process the same works in the opposite direction but the same challenges exist. Defining the functions, behaviors, strategy and vision are the difficult first step. When done correctly, specification of the physical architecture and component specification is straight forward.

Tangibles – Systems, Subsystems and Assemblies, Components

Product design is the process of creating a solution that meets the needs and expectations of the customers and the stakeholders. It involves designing and validating systems, assemblies or subsystems, and components that work together to deliver the desired functionality and performance.

A *system* is a set of interrelated subsystems or assemblies that form a whole and perform a specific function. For example, a car is a system that consists of various subsystems such as the engine, the transmission, the brakes, etc. A *system design* defines the overall architecture and specifications of the system, such as its inputs, outputs, interfaces, constraints, and requirements.

An *assembly* or a *subsystem* is a group of components that work together to perform a sub-function within the system. For example, the engine is a subsystem that converts fuel into mechanical power. An *assembly*

design defines the structure and configuration of the assembly or subsystem, such as its dimensions, materials, connections, tolerances, and testing methods.

A *component* is a single part or element that performs a specific task within the assembly or subsystem. For example, a piston is a component that moves up and down inside the cylinder of the engine. A *component design* defines the shape and properties of the component, such as its geometry, surface finish, strength, durability, and manufacturability. While mostly outside the scope of a mechanical design focus text, software can also be implemented at the component or assembly level.

By designing and validating systems, assemblies or subsystems, and components in a systematic and iterative way, product designers can create solutions that meet the needs and expectations of the stakeholders. The process of product design moves from the system level to the component level. Components are synthesized into assemblies and assemblies into systems. This process is described in the chapter on detailed design.

Function, Behavior, Performance, and Strategy/ Vision

A *function* is the purpose or goal of a product design. It describes what the product is intended (by designers) to do or achieve for the user or the environment. A function can be expressed as a verb and a noun, such as “to store books” or “to filter water”. A product design can have one or more functions, depending on its complexity and scope. Additionally, a product has both high-level functions (a car transports people) and numerous sub functions (safely secure passengers, cool passengers).

A function is an essential aspect of product design, as it guides the design process and influences the form, materials, features, and aesthetics of the product. A function also helps to evaluate the effectiveness and efficiency of a product design, by comparing the intended function with the actual performance and user feedback. We will revisit functions and functions structures in Chapter 5 on conceptual design development.

As function describes the intended actions of a product, *behavior* is a description of the actual actions of components and products. Behavior is the physical phenomena needed to express a function. For example, the function of converting electrical energy into rotational mechanical energy is an idea that can be expressed as the electromotive force. Behavior can be described using equations relating parameters. Such as converting electrical voltage and current (electrical power) to torque and rotational speed (mechanical power). Components implement one or more behaviors in order to express a desired function. A DC motor implements the function of conversion of electrical power to mechanical power using the physical principle of the electromotive force. One of the major challenges of design is that components don’t exhibit only a single behavior. A DC motor also exhibits vibration and heat. These are not usually the primary desired functions, however, designers must consider them as well. Functions of heat transfer and vibration management also must be expressed through behavior and ultimately lead to specification of components such as housings and heat sinks. This leads to a few important principles:

1. Functions, Behaviors, and Components (sometimes called structures) are closely tied together in the design process. A choice in any domain affects others.
2. The same function can be implemented with many different behaviors and components, selecting one solution too early in design process unnecessarily constrains the available design choices later.
3. The decision process for function, behavior and component are cyclical. Meaning that new additional functionality is often needed when a behavior or component is specified.

Structure-Behavior-Function is a formal modeling perspective – See more here:



One or more interactive elements has been excluded from this version of the text. You can view them online here: <https://uark.pressbooks.pub/mechanicaldesign/?p=72#oembed-1>

The concept of performance or quality was discussed in the previous section. To reiterate here, the choice to what level of behavioral performance (fuel efficiency for example) and which areas of performance to focus on define your technical competitive strategy. As you will see when we discuss developing specifications, setting these targets is essential for developing competitive products.

Design Strategy and Product Vision

Finally, we will consider the role of *design strategy* or, more elegantly, *product vision*. This intangibles concept affects the design decisions and thus the final outcome of the product design process. In the product marketplace, there are often many different manufacturers for the same general product. The sum of what differentiates them is their different design strategies. When designing a product, you will make many choices considering functionality, behaviors, components and levels or performance. What should guide that process is your product vision.

A vision in the context of product design provides us with a personal, inspiring image of a new future situation created by a designer or a group of designers and/or other professionals. This new future situation may directly concern the new product itself (features, functions etc.), but also the domain and context within which the product will be used, the user(s), the usage (or interaction) of the user(s) with the product, the business or other aspects related to the product design. A design vision includes:

1. an insight into or understanding of the product-user-interaction-context system;
2. a view on the essence of the problem: “which values are to be fulfilled?”;
3. a general idea or direction about the kind of solutions to be expected.

A strong, convincing vision is often well-founded by arguments based on theories and facts, and is often communicated effectively by using images, text and other presentation techniques. A design vision should be sharable and inspiring. As it is the result of the use of theories, facts and arguments, it should be an ‘objective’ interpretation.

Delft Design Guide.

Daalhuizen, Jaap. 2018. Delft Design Approach, Delft University of Technology.

CASE STUDY - DESIGN VISION

The following is an excerpt from the Delft Design Guide.

Daalhuizen, Jaap. 2018. Delft Design Approach, Delft University of Technology.

Design Vision

Function

The most important functions for the design are:

- Transport children on water, the toy needs to float on water, the transportation function enables that children can take part in competitions and water cycle
- Transform muscle strength into driving force; the children have to use of the driving mechanism to move the water cycle
- Teach children something about mechanics; one of the goals of the company is to introduce children to mechanics and how the product works
- Children should enjoy themselves; of course this has to be a result of the points listed above

Target Group

The most important target group are children from 7 – 11 years. Nevertheless the product also needs to be used by youngsters and elder people. A distinctive characteristics of this group is the ability to swim thus need less guarding. Children have a lot of fantasy and have a keen interest in mechanics. The other relevant group is camping users or café users next to lakes. The intention is that these people buy the product to provide children with maximum fun. These people do not care about the product. They only want that it is stored very well during winter at minimum maintenance.

Interested Party

The remaining interested party are the parents. They want their child to have fun and at the same time be safe without their constant guard. Others concerned are other water users who should experience minimum inconvenience from the product, the water cycle.

Environment for use

The product is going to be used on lakes next to campings and other recreational areas. Lakes have no current, often little beaches with grass on them. Lakes often have little cafes or toilet spots which could serve as storage space for the product.

Relation with other products

The product will have to compete with other water game activities. Other products can be water cycles, beach balls but also bigger beach balls or rubber boats. The unique quality of this product is that it embodies all of these functions including the fantasy aspect of the target group.

Distinguishing aspects

The product needs to command attention in between all other activities in such a lake. It has to come across as very safe. The product needs to be produced as environmentally friendly as possible and should resist long term influences of sand, water and sunlight.



AI generated image concept for a water cycle kid's toy.

How do we set our Design Goals or Vision?

The following is an excerpt from the Delft Design Guide.

Daalhuizen, Jaap. 2018. Delft Design Approach, Delft University of Technology.

What Is a Strategy Wheel?

A strategy wheel is a visual representation and a quick tool to review a company's strengths (see figure 2.1). A strategy wheel presents the company's competencies on the axes, and the scores of the competencies on those axes. By using the diagram, you obtain a quick understanding of the company's strategic strengths. Often it is useful to construct strategy wheels of a company's direct competitors. A product innovation process (see section 1.2 *in the PDF linked above*) starts with a clear understanding of the current situation of a company. The need for a new product arises from an understanding of a company's strategic strengths and weaknesses, and the opportunities in the market. A thorough analysis of the current situation of a company yields an understanding of the company's strategic strengths (for example: technical know-how, product portfolio, development (capability), financial position, export

know-how, marketing, organization and personnel, management). The strategy wheel is sometimes used to compare other things than a company's strategic position. For example, design concepts can be analyzed and reviewed using the strategy wheel (see fig. 2.1). The axes represent design requirements on which the design concepts are evaluated. The strategy wheel then yields a visual representation of the scores of the different design concepts on the design requirements. Also, there are various adaptations of the strategy wheel (for example the 'EcoDesign Strategy Wheel', in this section).

fig. 2.1 Strategy Wheel (Buijs and Valkenburg, 1996)

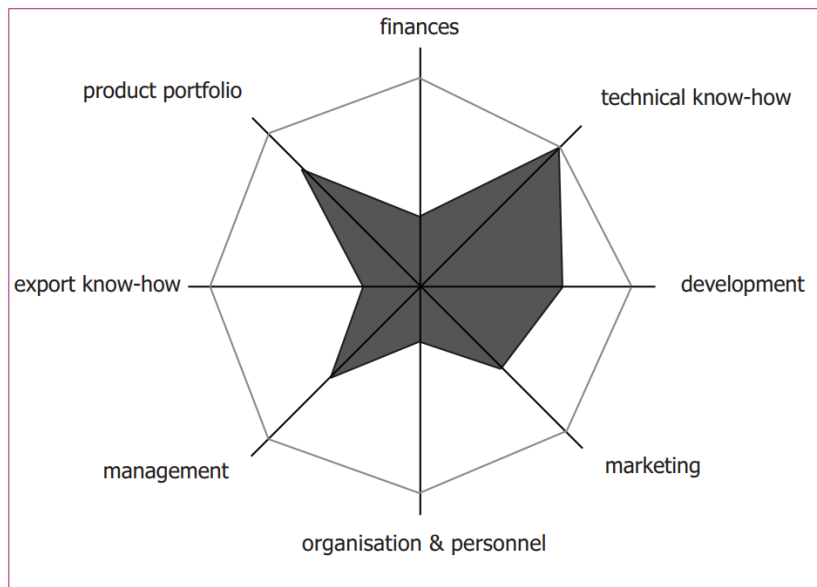

Strategy Wheel showing company strengths.

When Do You Use a Strategy Wheel?

A strategy wheel is usually applied in the beginning of a new product development process in order to present the strategic strengths of a company.

How to Use a Strategy Wheel?

Starting Point The results of an internal analysis form the starting point for the use of the strategy wheel: a clear understanding of the company's strategic strengths in relation to its direct competitors. **Expected Outcome** The outcome of the use of the strategy wheel is a visual representation and a better understanding of the company's strategic strengths.

For an example of using a strategy wheel see: [The Strategy Wheel \(The Big Picture View of How You Will Win\)](#)

MODELS – THE LANGUAGE OF DESIGN

What is a model?

One of the most important aspects of product design is communication. Communication between designers and developers, between developers and users, between users and other users. How can we ensure that everyone involved in the product development process understands the goals, the features, the constraints, and the feedback of the product? The answer is models.

Models are the language of product design. They are simplified representations of reality that capture the essential aspects of a product and omit the irrelevant details. Models can take many forms, such as sketches, wireframes, prototypes, mockups, diagrams, flowcharts, user stories, personas, scenarios, etc. Models help designers to explore ideas, test assumptions, validate solutions, and communicate with stakeholders. Models also help developers to implement the product according to the design specifications and user needs. Models also help users to learn how to use the product and provide feedback on their experience.

Models are not static or final. They are dynamic and iterative. They evolve as the product design process progresses and as new information and insights emerge. Models are not meant to be perfect or complete. They are meant to be useful and meaningful. Models are not meant to be taken literally or rigidly. They are meant to be interpreted and adapted. Models are not meant to be isolated or independent. They are meant to be connected and integrated.

Models are the language of product design because they enable effective communication across different levels of abstraction, different stages of development, and different perspectives of involvement. By using models, product designers can create products that meet the needs and expectations of their users and stakeholders. Throughout the design process, you will develop and communicate with many different types of models. Let's look at the most common types and their value.

Symantec or Text-Based Models

A semantic model is a way of describing a product or a system using natural language. It can help designers and stakeholders to communicate the purpose, functionality, and structure of the product or system. For example, a semantic model for a car might include statements like “A car is a vehicle that transports people and goods”, “A car has four wheels, an engine, a steering wheel, and a brake pedal”, and “A car can accelerate, decelerate, turn left, and turn right”. A semantic model can convey the essential features and behaviors of the product or system, as well as the relationships and dependencies among its components. Semantic models can also help to

identify gaps, inconsistencies, or ambiguities in the design process. Typically, customer needs and engineering requirements are represented as semantic models.

Semantic models, like any type of model, have some limitations.

- – They may not capture the symbolic qualities of form that convey psychological, social and cultural context to the users. Language is limited to describe the “feel” of a product.
- – They may not account for the diversity of views and interpretations among different users and organizations as it is impossible to capture all views in a limited amount of useful text.
- – They may not communicate effectively with other domains, such as manufacturing and engineering. With different standards and terminology, various misunderstanding can occur.

Graphical Models



An example of a graphical model – A CAD based model. Source: https://commons.wikimedia.org/wiki/File:CAD_Model.JPG

Graphical models such as drawings, CAD models, and sketches are essential tools for product design. They allow designers to visualize their ideas, explore different options, and communicate with other designers and stakeholders. Graphical models can also help designers to test their assumptions, identify potential problems, and evaluate the feasibility and usability of their products. Graphical models include: 1) **Concept sketches** that are quick and rough drawings that capture the main features and functions of a product. They are used to generate and compare different alternatives in the early stages of design. 2) **Technical drawings** that are detailed and precise drawings that show the dimensions, materials, and specifications of a product. They are used to document and communicate the final design for manufacturing and assembly. 3) **CAD models** that capture the geometric information of components, parts and assemblies. These are useful for developing analytical models and generating technical drawings.

- – However, graphical models also have some limitations such as:
- – They may not capture all the aspects and complexities of a product, such as its behavior, performance, or context of use.
- – They may be misinterpreted or misunderstood by different audiences, especially if they are not accompanied by clear explanations or annotations.
- – They may become outdated or irrelevant as the design process progresses and new information or feedback emerges.

Analytical Models

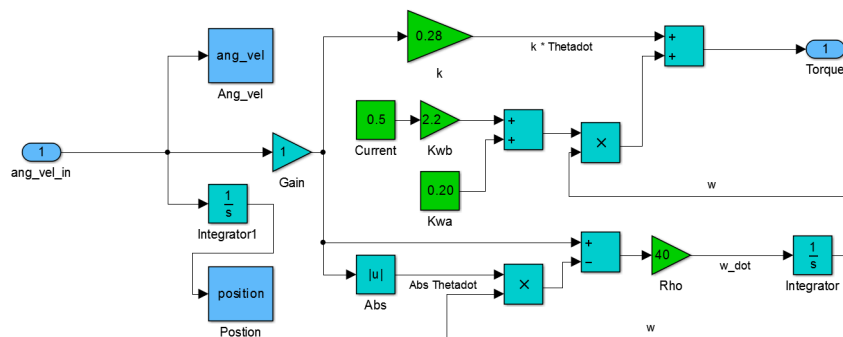

An example of an analytical model. Often these are implemented with analysis software like Matlab.

Analytical models are mathematical representations of physical phenomena or systems that can be used in product design. They can take the form of equations or simulations that describe the behavior, performance, or interactions of a product or its components. For example, an analytical model can be used to calculate the stress and strain on a bridge, the airflow and drag on an airplane, or the heat transfer and energy consumption of a refrigerator.

Analytical models have several advantages in product design. They can help designers to explore different design alternatives, optimize design parameters, and evaluate design trade-offs. They can also help designers to communicate their design rationale and decisions to other stakeholders, such as customers, managers, or regulators. By using analytical models, designers can demonstrate how their product meets the design specifications, requirements, and constraints.

However, analytical models also have some limitations in product design. They often rely on simplifying assumptions and idealizations that may not reflect the real-world conditions or uncertainties. They may also be inaccurate or incomplete due to lack of data, measurement errors, or modeling errors. Therefore, analytical models should not be used as the sole basis for design decisions, but rather as a tool to support design reasoning

and validation. Analytical models should be verified and validated by comparing them with experimental data, empirical evidence, or other sources of information.

Physical Models – Prototypes

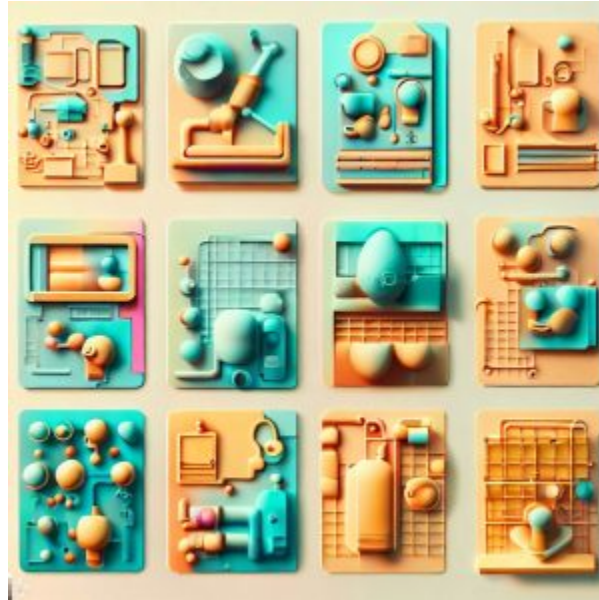

Generated image illustrating 3D printing as a method for developing physical prototypes.

Physical models are tangible representations of a product design that can be used for various purposes, such as testing, evaluation, communication and demonstration. Physical models can range from proof-of-concept prototypes and mock-ups to high-fidelity prototypes and final products.

A ***proof-of-concept prototype*** is a working model that demonstrates the feasibility of an idea. It is used in the early stages of product development to decide whether an idea is feasible enough to develop. A proof-of-concept prototype can help prevent resource waste, inform investors, identify roadblocks, and get ahead of the competition. However, a proof-of-concept prototype also has some limitations. It does not show how the product will look, function, or perform in the real world. It does not test the user experience, usability, or market demand of the product. It does not guarantee the success or profitability of the product. Therefore, a proof-of-concept prototype is only the first step in bringing an idea to life, and it should be followed by other stages of development such as prototyping, piloting, and minimum viable product (MVP).

An ***industrial prototype*** is a sample of the final product that is used to test and evaluate its usability and aesthetics. It is useful for exploring solutions for the shape, feel, and interactions, identifying potential problems, and making changes before final production. Industrial prototypes can be expensive, time-consuming, and wasteful depending on the number of iterations and revisions required. It can also be

challenging to ensure that the prototype matches the final product in terms of quality, performance, and reliability. Developing useful industrial prototypes often requires finding skilled technical artists to properly develop a useful model.

A ***functional prototype*** is a type of prototype that demonstrates the functionality and performance of a product. It is useful for testing the feasibility, usability and user satisfaction of a product before launching it to the market. However, a functional prototype may not reflect the final appearance, materials or dimensions of a product, and it may require more time and resources to develop than other types of prototypes. A functional prototype will often not address uncertainty in manufacturing methods or consumer satisfaction.

A ***manufacturing or assembly prototype*** is a physical model of a product that is made using the same materials, manufacturing, and assembly processes as the final product. These are often called “Alpha prototypes” as well. They are useful for testing the functionality, quality and durability of the product before mass production. It is also useful for validating the desired manufacturing and assembly process and procedures. The limitations of a manufacturing prototype are that it can be expensive, time-consuming and risky to produce, and it may not reflect the actual market demand or customer feedback for the product.

In later chapters we will discuss the development of different types of prototypes and their value in the design process.

WRAP UP - DESIGN PRIMITIVES AND FUNDAMENTALS

Summary of Key Concepts

- Designing versus problem solving
- Satisficing of stakeholder needs
- Tangible versus intangibles in the design specification
- The value and types of models in product design

Part 2 Questions



An interactive H5P element has been excluded from this version of the text. You can view it online here:

<https://uark.pressbooks.pub/mechanicaldesign/?p=279#h5p-2>

PART III

DESIGN TEAMS AND DESIGN PROJECT MANAGEMENT

Learning Objectives

In this chapter we will discuss how to identify and define a project opportunity and how to put together and manage a team to be effective in a product design project. Readers will be able to:

- Apply tools to define the risks and potential gains for a design opportunity.
- Describe the process of decision-making at the individual and team level.
- Use tools to manage project deliverable times and responsibilities.
- Understand and practice being an effective design team member.

A product design project is a complex and dynamic process that requires a clear understanding of the problem, the context, and the goals. One of the first steps in any product design project is to identify and define a project opportunity, which is a gap or a need that can be addressed by a new or improved product. A project opportunity can arise from various sources, such as customer feedback, market research, technological innovation, or social trends. To define a project opportunity, we need to answer questions such as: Who are the potential users and customers of the product? What are their needs, wants, and preferences? What are the existing solutions and competitors in the market? What are the technical, economic, environmental, and ethical constraints and criteria for the product? How can we measure the success of the product?

Another important step in a product design project is to put together and manage a team that can work effectively and efficiently to achieve the project goals. A product design team typically consists of people with different skills, backgrounds, and perspectives, such as engineers, designers, marketers, managers, and customers. A product design team needs to have a clear vision, mission, and strategy for the project, as well as a well-defined division of roles and responsibilities. A product design team also needs to communicate frequently and openly, to share information, ideas, feedback, and decisions. A product design team should

also foster a culture of collaboration, creativity, and innovation, where team members respect each other's opinions, support each other's efforts, and learn from each other's experiences.

IDENTIFY AND DEFINE A PRODUCT DESIGN OPPORTUNITY

A product design opportunity is a gap or a need in the market that can be addressed by creating a new or improved product. To identify and define a product design opportunity, the following steps can be followed:

1. Conduct a market research to understand the current trends, customer needs, competitors, and existing solutions in the domain of interest.
2. Define the problem statement that clearly describes the problem to be solved, the target users, and the desired outcomes or benefits of the solution.
3. Generate and evaluate ideas for possible solutions that meet the problem statement and the user needs. Consider the feasibility, viability, and desirability of each idea.
4. Select the best idea and refine it into a product concept that specifies the main features, functions, and benefits of the product.
5. Validate the product concept with potential users and stakeholders to get feedback and improve the design.

Ideally all of these are completed before significant amount of technical engineering design work is committed. There is an art to committing the right amount of engineering analysis resources and person-hours to completely define a design project opportunity. Committing many person-hours towards detailed analysis prior to commitment from management or external stakeholders can a waste if not pushed forward through the design stage. Alternatively, committing resources to a poorly researched design opportunity is a guaranteed path to failure. Is formalized structure helps to identify the pros and cons of pursuing a potential design project and can help acquire stakeholder buy in. One tool for defining a potential project is called a SWOT (Strength, Weakness, Opportunity, and Threat) analysis.

SWOT Analysis

A SWOT analysis is a strategic tool that helps to evaluate the internal and external factors that affect the success of a product design opportunity. It stands for Strengths, Weaknesses, Opportunities and Threats. Strengths are the positive attributes of the product or the organization that give it an advantage over others. Weaknesses are the negative aspects that limit the product's performance or hinder its development. Opportunities are the favorable situations or trends in the market or environment that create new possibilities for the product.

Threats are the unfavorable conditions or risks that pose challenges or threats to the product’s viability or profitability.

SWOT-аналіз



Typical layout of a SWOT Analysis. Source:
[https://commons.wikimedia.org/wiki/
 File:SWOT_en.svg](https://commons.wikimedia.org/wiki/File:SWOT_en.svg)

A SWOT analysis can help to identify and prioritize the key factors that influence the product design opportunity and to generate ideas for improvement or innovation. To conduct a SWOT analysis, follow these steps:

1. Define the product design opportunity clearly and specifically.
2. Brainstorm and list all the relevant strengths, weaknesses, opportunities and threats for the product design opportunity.
3. Analyze and evaluate each factor in terms of its importance and impact on the product design opportunity.
4. Organize and summarize the results in a matrix or a table with four quadrants, one for each category of SWOT.
5. Use the SWOT analysis to formulate strategies and actions that leverage the strengths, overcome the weaknesses, exploit the opportunities and mitigate the threats.

For example, suppose a company wants to design a new smartwatch that can monitor health and fitness data. A SWOT analysis for this product design opportunity could look like this:

STRENGTHS	WEAKNESSES
<ul style="list-style-type: none"> – Innovative features and functions – Strong brand reputation and customer loyalty <ul style="list-style-type: none"> – Experienced and skilled design team 	<ul style="list-style-type: none"> – High cost of production and maintenance – Limited battery life and compatibility <ul style="list-style-type: none"> – Regulatory and ethical issues
OPPURTUNITIES	THREATS
<ul style="list-style-type: none"> – Growing demand and interest in wearable devices – Potential partnerships with health care providers and fitness centers <ul style="list-style-type: none"> – Emerging markets and segments 	<ul style="list-style-type: none"> – Intense competition from existing and new players – Rapid changes in technology and customer preferences <ul style="list-style-type: none"> – Legal and security risks

Using a SWOT Analysis

Based on this SWOT analysis, some possible strategies and actions for the product design opportunity could be:

- Differentiate the product from competitors by offering unique features and functions that add value to customers.
- Reduce the cost of production and maintenance by optimizing the design process and using cheaper materials or components.
- Extend the battery life and compatibility by improving the software and hardware integration and offering wireless charging options.
- Address the regulatory and ethical issues by complying with relevant laws and standards and ensuring data privacy and security.
- Promote the product to potential customers by highlighting its benefits and advantages over other products.
- Seek partnerships with health care providers and fitness centers to increase the market reach and credibility of the product.
- Explore new markets and segments by adapting the product to suit different needs and preferences of customers.
- Monitor the market trends and customer feedback to keep up with the changes in technology and customer expectations.
- Anticipate and prepare for possible legal and security risks by implementing appropriate measures and contingency plans.

Some people have a strong interest and desire to explore the business aspect of new product design. For more content for those interested in entrepreneurship see Ch. 5 Introduction – Entrepreneurship | OpenStax

TEAM-BASED DESIGN DECISION MAKING

Models of Team-Based Decision-Making

One of the challenges that product teams face is how to make effective decisions that lead to successful outcomes. There are different models of team decision making that can be applied depending on the situation, the time available, and the level of participation required. As you can see, some of the same models for individual decision making apply to group decision making.

Rational decision model

This model focuses on using logical steps to come up with the best solution possible. It involves defining the goal or problem, gathering relevant information, generating a list of options, evaluating the pros and cons of each option, and choosing the optimal one. This model is useful when there is enough time and data to analyze multiple solutions and compare their quality.

Vroom-Yetton decision model

This model was designed for collaborative decision making and helps determine how much input should be sought from team members. It involves answering a series of questions about the nature and importance of the decision, the availability and expertise of team members, and the likelihood of acceptance and commitment. Based on the answers, the model suggests one of five decision styles: autocratic, consultative, facilitative, delegative, or collaborative.

Tuckman's FSNP/FSNPA model

This model describes the stages of team development and how they affect decision making. The stages are forming (when team members get to know each other), storming (when team members experience conflicts and disagreements), norming (when team members establish norms and expectations), performing (when team members work effectively and efficiently), and adjourning (when team members complete the task and disband). This model is useful for understanding how team dynamics change over time and how to adapt decision making accordingly.



One or more interactive elements has been excluded from this version of the text. You can view them online here: <https://uark.pressbooks.pub/mechanicaldesign/?p=86#oembed-1>

Lencioni model

This model identifies five dysfunctions that can hinder team decision making and performance: absence of trust, fear of conflict, lack of commitment, avoidance of accountability, and inattention to results. It also provides strategies to overcome each dysfunction and build a cohesive and productive team. This model is useful for diagnosing and resolving issues that may affect team decision making.



One or more interactive elements has been excluded from this version of the text. You can view them online here: <https://uark.pressbooks.pub/mechanicaldesign/?p=86#oembed-2>

Can groups even make decisions?

One mathematical caveat to the above. There is good evidence that there is no such thing as a perfect team-based decision. In fact, it may be that teams cannot actually make decisions, only individuals can. However, in reflection, after a design is developed, many individuals describe the “team” as coming to consensus. In the detailed design stage, we will discuss the tools to support design decision making.

Specifically, Arrow's impossibility theorem is a mathematical result that shows that there is no perfect way to aggregate individual preferences into a collective decision. This has important implications for product design decision making in a design context, where designers often have to balance the needs and wants of different stakeholders, such as users, clients, managers, and themselves. One way to deal with this challenge is to use a structured process that involves defining the problem, generating alternatives, evaluating criteria, and selecting the best option. However, even this process may not guarantee a satisfactory outcome for everyone involved, as different criteria may conflict or contradict each other. Therefore, product designers need to be aware of

the limitations and trade-offs of any decision-making method they use and communicate them clearly and transparently to the relevant parties.

The implication of this mathematical theory is that the best we will identify is tools and best practices for defining and selecting the best option in any decision-making stage.

INDIVIDUAL DESIGN DECISION MAKING

Models of Human Decision Making

Every human has a lifetime of experience in decision making. However, it is helpful to be reflective on how we make decisions, especially as it related to developing products.

All decision making is the process of choosing among different options or courses of action. There are different general models of decision making that can help individuals or organizations to make better decisions, especially with respect to product design decisions making.

Rational model

This model follows a sequence of logical steps to analyze the problem, gather relevant information, generate possible solutions, evaluate the pros and cons of each option, and select the best one based on objective criteria. The rational model relies on data, logic, and analysis to make decisions. For example, a company might use this model to decide which new product to launch based on market research and cost-benefit analysis.

Intuitive model

This model relies on gut feelings, instincts, or hunches to make decisions. The intuitive model does not require much information or analysis, but rather trusts the decision maker's experience and intuition. For example, a manager might use this model to hire a new employee based on their impression during the interview.

Vroom-Yetton model

This model considers the level of participation and involvement of others in the decision making process. The Vroom-Yetton model suggests that different situations require different degrees of autocratic, consultative, or democratic decision-making styles. For example, a leader might use this model to decide how much to involve their team members in a strategic decision based on factors such as time pressure, quality requirements, and acceptance needs.



One or more interactive elements has been excluded from this version of the text. You can view them online here: <https://uark.pressbooks.pub/mechanicaldesign/?p=84#oembed-1>

Recognition-primed model

This model describes how experts make decisions in complex and uncertain situations. The recognition-primed model assumes that experts can quickly recognize patterns and cues from their previous experience and use them to generate and evaluate a single option that works. For example, a firefighter might use this model to decide how to respond to an emergency based on their knowledge and skills.

Bounded rationality model

This model acknowledges the limitations and constraints that affect human decision making. The bounded rationality model suggests that people cannot process all the information available or consider all the alternatives possible, so they use heuristics or rules of thumb to simplify the decision-making process and choose a satisfactory option rather than an optimal one. For example, a consumer might use this model to decide which brand of cereal to buy based on availability, price, or familiarity.

Creative model

This model emphasizes the generation of novel and original solutions to problems. The creative model involves divergent thinking, brainstorming, experimentation, and feedback to produce innovative and unique outcomes. For example, a designer might use this model to create a new logo for a company based on inspiration, imagination, and iteration.

Designers make decisions that could be accurately described by many of these models depending on the context. The most important part is that designers are reflective of their own thinking and the potential limitations that may impact those decisions. For example, rational and bounded rationality methods can be

overly reliant and overly confident on limited information. Intuitive methods are subject to a host of natural human biases in thinking.

PROJECT TIMELINE MANAGEMENT

Timelines and Deliverables

A timeline management solution is essential for a product design project, as it helps to plan, monitor and control the various tasks and deliverables involved. A timeline management solution can help to define the scope, objectives and milestones of the project, as well as assign roles and responsibilities to the team members. It can also help to track the progress and status of the project, identify potential risks and issues, and communicate effectively with the stakeholders. A timeline management solution can improve the efficiency, quality and success of the product design project.

Gantt Charts

A Gantt chart is a graphical tool that helps product design development teams to plan, coordinate, and track their tasks and progress over time. A Gantt chart shows the start and end dates of each task, the dependencies between tasks, the milestones and deliverables, and the allocation of resources. A Gantt chart can provide several benefits for product design development projects, such as:

- – It can help to define the scope and objectives of the project and break them down into manageable tasks.
- – It can help to estimate the duration and cost of each task and the overall project.
- – It can help to identify and mitigate potential risks and issues that may arise during the project.
- – It can help to communicate and collaborate with stakeholders and team members on the project status and expectations.
- – It can help to monitor and control the project performance and quality and make adjustments as needed.

Therefore, a Gantt chart is a valuable tool for product design development teams to plan, execute, and evaluate their projects effectively and efficiently.

Here are some detailed steps for creating a Gantt chart for a mechanical product design project:

1. Define the scope and objectives of the project. What are you trying to achieve with your product design?

What are the main features and functions of the product? What are the deliverables and deadlines of the project?

2. Break down the project into phases and tasks. Identify the major phases of the product design process, such as research, ideation, prototyping, testing, and manufacturing. Then, divide each phase into smaller and more manageable tasks that can be assigned to different team members or groups.
3. Estimate the duration and effort of each task. How long will each task take to complete? How much time and resources will each task require? Use historical data, expert opinions, or estimation techniques to determine realistic durations and efforts for each task.
4. Identify the dependencies and constraints of each task. How do the tasks relate to each other? Which tasks need to be completed before others can start? Which tasks can be done in parallel or overlap? What are the external factors that may affect the completion of the tasks, such as availability of materials, equipment, or personnel?
5. Create a Gantt chart using a software tool or a spreadsheet. Enter the tasks, durations, dependencies, and milestones into a Gantt chart tool or a spreadsheet program that can generate a Gantt chart. Adjust the start and end dates of each task according to their dependencies and constraints. Use different colors or symbols to indicate different phases, groups, or priorities of the tasks.
6. Review and refine the Gantt chart with your team and stakeholders. Share the Gantt chart with your team members and stakeholders and get their feedback and approval. Make sure everyone understands their roles and responsibilities and agrees on the timeline and scope of the project. Update the Gantt chart as needed to reflect any changes or revisions.
7. Monitor and control the progress of the project using the Gantt chart. Use the Gantt chart as a communication and tracking tool throughout the project lifecycle. Compare the actual progress of each task with the planned progress on the Gantt chart. Identify any issues or risks that may cause delays or deviations from the plan. Take corrective actions or preventive measures to keep the project on track and on budget.



One or more interactive elements has been excluded from this version of the text. You can view them online here: <https://uark.pressbooks.pub/mechanicaldesign/?p=88#oembed-1>

Other Common Design Project Management Tools

There are some other common software tools used for project management. Regardless of your technical expertise, you will likely still need to interact with some sort of project management. It is highly advisable for students who want to demonstrate that they are ready for an internship or initial job to demonstrate competency with these common tools. Before your next internship or job interview, review the following tools and be ready to be conversant on them to demonstrate your readiness to be productive in their software ecosystem.

- Microsoft Project: This is a popular and widely used tool that allows users to create and manage project plans, assign tasks and resources, track progress and costs, generate reports and charts, and integrate with other Microsoft applications.

- Jira: This is a tool that focuses on agile project management methodologies, such as Scrum and Kanban. It enables users to create and prioritize user stories, manage sprints and backlogs, track issues and bugs, collaborate with team members, and visualize workflows and metrics.

- Trello: This is a tool that uses a simple and intuitive interface based on boards, lists, and cards. It allows users to organize and manage projects of any size and complexity, assign tasks and deadlines, add comments and attachments, create checklists and labels, and integrate with various apps and services.

- Asana: This is a tool that helps users to manage projects and workflows from start to finish. It allows users to create and share goals and milestones, assign tasks and subtasks, set due dates and dependencies, track progress and status updates, communicate with team members, and automate repetitive tasks.

- Basecamp: This is a tool that provides a centralized platform for project management and team collaboration. It allows users to create and join projects, add tasks and events, upload files and documents, chat with team members, send messages and announcements, and monitor activity and feedback.

PROJECT TEAM MANAGEMENT

Document and Communication Management

Document sharing services are a critical part of collaboration on product designs. They allow you to share files with team members, track changes, and provide feedback all in one place. This can save you a lot of time and hassle, and it can help to ensure that everyone is on the same page.

Some of the benefits of using a document sharing service include:

- **Collaboration:** Document sharing services make it easy to collaborate on product designs with team members who are located in different places. You can share files, track changes, and provide feedback all in one place.
- **Version control:** Document sharing services typically provide version control, which means that you can track changes to files over time. This can be helpful if you need to revert to a previous version of a file or if you need to see how a file has evolved over time.
- **Security:** Document sharing services typically offer security features, such as password protection and file encryption. This can help to protect your files from unauthorized access.
- **Ease of use:** Document sharing services are typically easy to use. You can typically upload files to a service, share them with others, and track changes with just a few clicks.

If you are working on a product design project, I recommend using a document sharing service. It can save you a lot of time and hassle, and it can help to ensure that everyone is on the same page.

Here are some specific examples of document sharing services that can be used for product design:

- **Dropbox:** Dropbox is a popular document sharing service that offers a variety of features, including version control, security, and ease of use.
- **Google Drive:** Google Drive is another popular document sharing service that offers similar features to Dropbox.
- **Microsoft OneDrive:** Microsoft OneDrive is a document sharing service that is offered by Microsoft. It offers a variety of features, including version control, security, and integration with other Microsoft products.

In the industrial design context, secure file sharing is critical to protecting intellectual property as well. There are thousands of successful phishing attacks on industrial and manufactures every year. One important part

of continuous education for designers is understanding the latest potential avenues for threats to intellectual property and other critical information.

Having a **secure communication plan** is also a key element for successful design teams and protection of intellectual property. The easiest way to breakdown team cohesion and effectiveness is miscommunication about communication expectations. Make expectations clear early on how your team communicates (emails, weekly meetings etc.) and individual's responsibilities to be involved in those communications and meetings.

The Character of Effective Teams

Personnel management on product design teams is a crucial aspect of delivering successful products that meet user needs and business objectives. However, product design teams often face common challenges such as:

1. Aligning the team's vision and goals with the product strategy and roadmap
2. Communicating and collaborating effectively across different functions and disciplines
3. Balancing user feedback, stakeholder expectations, and technical constraints
4. Managing team workload, resources, and deadlines
5. Fostering a culture of innovation, learning, and growth

To overcome these challenges, product design teams can use various tools and best practices, such as:

- Creating cross-functional squads or pods that work on a specific part of the product or user problem
- Establishing clear roles and responsibilities for each team member and ensuring accountability
- Using agile methodologies and frameworks to plan, execute, and iterate on product development
- Adopting user-centric design processes and methods to understand, validate, and test product ideas
- Leveraging collaboration tools and platforms to share information, feedback, and ideas
- Conducting regular team meetings, reviews, and retrospectives to align, communicate, and improve
- Providing team members with opportunities for learning, development, and recognition

Perception of Equitable Work Distribution

One of the key factors for a successful design project is to ensure that everyone on the design team feels like their contributions are equitable and appreciated. This means that each team member has a clear role and responsibility, that their input is valued and respected, and that they receive constructive feedback and recognition for their work. Equitable and appreciated contributions can foster a sense of belonging, trust, and collaboration among the team members, as well as increase their motivation, creativity, and satisfaction. A

design team that feels equitable and appreciated can also produce better outcomes for the project, as they can leverage their diverse perspectives, skills, and experiences to create innovative solutions that meet the needs and expectations of the stakeholders.

Best Practice to Support Creativity, Ingenuity, Innovation

Creativity, ingenuity, and innovation are essential qualities for a design team to produce solutions that meet the needs and expectations of their clients and users. However, no tool or method will overcome an ineffective team culture.

Some Strategies for Better Team Dynamics

Read the following Harvard Business Review article: Making Dumb Groups Smarter by Cass R. Sunstein and Reid Hasti

Summary:

Silence the Leader

To avoid self-censorship in groups, leaders should welcome diverse opinions and avoid stating their own views too soon. Leaders can also help low-status members, such as minorities or women, to have more influence by showing an open mind and asking for honest feedback. This way, groups can benefit from more information and better decisions.

Prime Critical Thinking

Group members may self-silence when they fear punishment for dissenting opinions. However, social norms can be influenced by priming, which activates certain thoughts or associations. Experiments show that priming people with either “getting along” or “critical thinking” affects their willingness to share information. Therefore, group leaders should promote information disclosure from the start, even if it challenges the group consensus.

Reward Group Success

When group success is rewarded, individuals have an incentive to cooperate, share information, and seek consensus. This can lead to more accurate and rational judgments, as well as higher levels of creativity and innovation.

Assign Roles

Individual bias decreases when team members are assigned specific roles. These can be a member's actual expertise (ideal) or member can play an expertise role. Someone considers manufacturing, another regulation and safety, etc.

Appoint a Devil's Advocate

Asking someone to *intentionally* take the role of contrarian can result in useful negative criticism and more open idea sharing. However, unasked for this can be potentially negative for the team's decision-making. Another approach is to appoint a contrarian team to provide critical feedback.

WRAP UP - DESIGN TEAMS AND DESIGN PROJECT MANAGEMENT

Summary of Key Concepts

- SWOT analysis and the value of having a clear project vision and definition before beginning a design project.
- What are the models of individual and team decision making. When will you use each type of method?
- What practical aspects will you need to help implement to have a successful project team?

Part Questions



An interactive H5P element has been excluded from this version of the text. You can view it online here:

<https://uark.pressbooks.pub/mechanicaldesign/?p=281#h5p-3>

PART IV

DEFINING AND MANAGING DESIGN REQUIREMENTS

Learning Objectives

In this chapter we explore how to identify stakeholder needs and develop those into criteria by which we can evaluate the success of a concept or design. Reader will be able to:

- Define who are stakeholders for a design opportunity.
- Utilize various tools for gathering and quantifying stakeholder needs.
- Develop testable engineering specifications to evaluate concepts.

Introduction

One of the most important steps in product design is identifying who are the stakeholders of the product and what are their wants and needs. Stakeholders are any individuals or groups who have an interest in or are affected by the product, such as customers, users, manufacturers, suppliers, distributors, regulators, competitors, etc. Their wants and needs are the problems they face or the goals they want to achieve with the product.

However, wants and needs are often vague, subjective, and conflicting. They may not be explicitly stated or easily observable. They may also change over time or vary across different contexts and situations. Therefore, product designers need to have effective methods and tools to elicit, analyze, prioritize, and validate the wants and needs of different stakeholders.

Once stakeholder wants and needs are clearly defined, they need to be translated into technical specifications that can guide the design process. Technical specifications are measurable and testable requirements that

specify what the product should do, how well it should do it, and under what conditions it should do it. They define the performance, functionality, quality, reliability, safety, usability, and aesthetics of the product.

By correctly gathering needs, developing specifications, and then designing to those specifications, we can design successful products that satisfy the stakeholders and meet their expectations. This chapter will introduce some of the key concepts and techniques for identifying stakeholders, determining their wants and needs, and interpreting those into technical specifications.

WHO ARE THE STAKEHOLDERS AND WHAT DO THEY WANT?



Who are these Stake-Holders – The Dad joke.

Stakeholders are individuals or groups who have an interest or influence in the outcome of a product design project. They can be internal or external to the organization that is developing the product. Some examples of stakeholders are:

- **Users:** The end-users of the product who will benefit from its features and functions. They have needs such as usability, reliability, affordability, and satisfaction.
- **Customers:** For many products, the end user may not directly pay for it. For example, consider the Online Learning software you use in this course. A student and a university might have different product needs for the same product. While many of their needs are similar to users, they may have other cost-based and product ecosystem needs.
- **Developers/Designers:** The people who create the product using various tools and technologies. They have needs such as clear requirements, adequate resources, feedback, and recognition. You are a stakeholder in your own design. This most often is seen when a product design fall outside of the designer’s expertise or available resources.
- **Managers:** The people who oversee the product development process and ensure that it meets the goals and expectations of the organization. They have needs such as budget, timeline, quality, and risk management.

– **Suppliers:** The entities that provide the materials, components, or services that are needed for the product development. They have needs such as timely payment, communication, and collaboration.

– **Regulators:** The authorities that enforce the laws, standards, or regulations that apply to the product or its domain. They have needs such as compliance, safety, and transparency.

Stakeholder needs can sometimes conflict with each other or with the product design objectives. For example:

– Customers may want a product that is easy to use and has many features, but designers may face technical challenges or resource constraints in delivering such a product.

– Managers may want a product that is delivered on time and within budget, but customers may demand changes or enhancements that require more time and money.

– Suppliers may want a long-term contract and a high price for their inputs, but managers may want to negotiate for lower costs and more flexibility.

– Regulators may want a product that meets strict criteria and undergoes rigorous testing, but developers may want to innovate and experiment with new solutions.

METHODS TO GATHER STAKEHOLDER NEEDS

One of the challenges of product design is to identify the correct stakeholders, understand their needs, and develop a design strategy that balances those needs. **Ethnographic methods** are a set of techniques for gathering stakeholder needs, especially from users and customers. Ethnographic methods involve observing, interviewing, and interacting with stakeholders in their natural contexts, to gain insights into their behaviors, preferences, motivations, and pain points. Some common ethnographic methods for gathering needs are:

- **Contextual inquiry:** A method of observing and interviewing stakeholders while they perform their tasks in their natural environment. This allows the designer to understand the context of use, the goals and challenges of the stakeholders, and the current workflows and processes.

- **Focus group:** A method of gathering feedback from a group of stakeholders who share similar characteristics or experiences. This allows the designer to explore different perspectives, opinions, and attitudes on a topic or a product concept.

- **Persona:** A method of creating fictional characters that represent different types of stakeholders. This allows the designer to empathize with the stakeholders, and to design for their needs, goals, and pain points.

- **Journey map:** A method of visualizing the steps and emotions that a stakeholder goes through when interacting with a product or a service. This allows the designer to identify the opportunities and challenges for improving the stakeholder experience.

- **Card sorting:** A method of asking stakeholders to sort a set of cards with words or images into categories that make sense to them. This allows the designer to understand how the stakeholders organize and label information, and to design an intuitive information architecture.

While not focused on mechanical product design, the following illustrates several important points when considering the customer and user stakeholders.



One or more interactive elements has been excluded from this version of the text. You can view them online here: <https://uark.pressbooks.pub/mechanicaldesign/?p=98#oembed-1>



CHECKLIST FOR GENERATING REQUIREMENTS

The following text is from the Delft Design Guide.

Daalhuizen, Jaap. 2018. Delft Design Approach, Delft University of Technology.

What are Checklists for Generating Requirements?

Checklists for Generating Requirements are lists of questions that you can ask yourself when creating a design specification (list of requirements) (see also 'Design Specification (Criteria)' in this section). Checklists ensure that you adopt a systematic approach to the creation of the program of requirements. The most important thing is not to forget a particular requirement, meaning that we have to arrive at a complete collection of requirements. You can create a program of requirements by taking into account three points of view (see also 'Design Specification (Criteria)' in this section): (1) the stakeholders, (2) the aspects involved, and (3) the product life cycle. You can take these different points of view into account when generating requirements, and some provide explicit, clear-cut checklists (for example Pugh). Other points of view, for example the process tree, are not checklists by definition. However, they help the generation of requirements in the same way.

The Stakeholders

The aims and preferences of people set the requirements for a new product. Who are the people affected by the new product, what interests do they have, what do they decide on, and what information can they provide? Important stakeholders are the company, its (future) customers, suppliers, transport companies, wholesale and retail trade, consumer organizations, and legislators. An example of a checklist to distinguish relevant stakeholders can be found in Jones (1982).

Aspects Involved in Product Design

There are checklists of aspects which usually play a role in the assessment of a product. By aspects we mean such general issues as performance, environment, maintenance, aesthetics and appearance, materials, and packaging among others. Such checklists have been drafted by Hubka and Eder (1988), Pahl and Beitz (1984), and Pugh (1990) – see the example in figure 2.14.

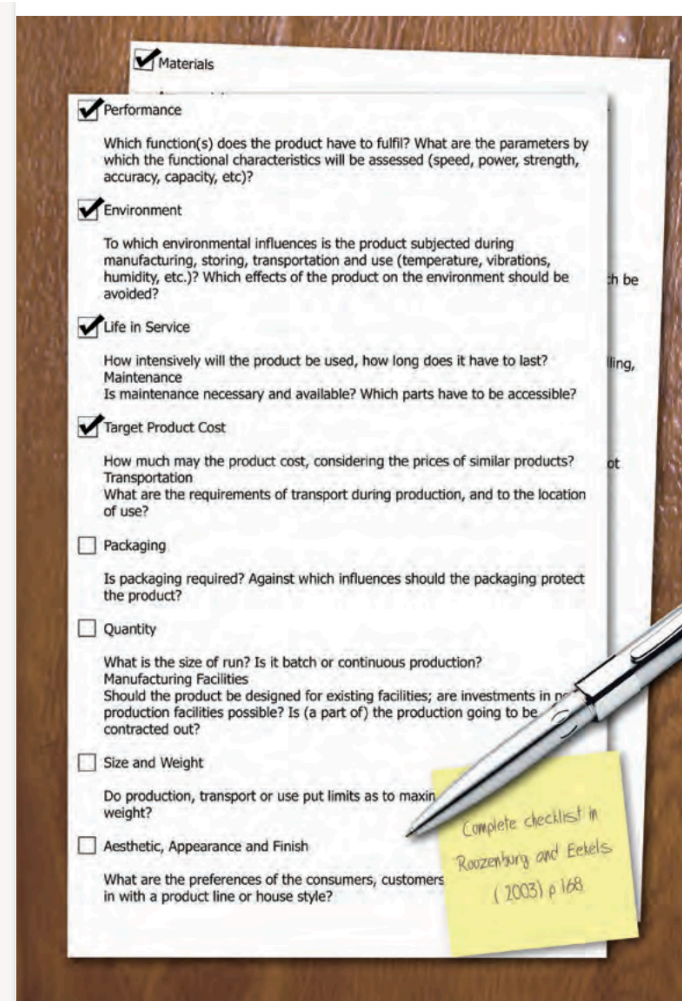

fig. 2.14 Example of a Problem Definition (from student report)

Example of a stakeholder

Product Process Tree

The process tree of a product (see 'Process Tree' in this section) provides a third viewpoint to arrive at a complete specification. Between its origination and disposal, a product goes through several processes, such as manufacturing, assembly, distribution, installation, operation, maintenance, use, reuse and disposal. Each of these processes comes with certain requirements and wishes for the new product. You become aware of these requirements by making a process tree.

Requirement Checklist	
Performance	What functions does the product need to fulfill. What are the parameters by which that function will be assessed? Such as speed, power, strength, etc.
Environment	What environmental factors will influence the product and how might the product influence the environment? Temperature, exposure to sunlight, chemical or biological resistance.
Life in Service	How intensively will the product be used? How long does it have to last? Is maintenance necessary? Which parts need to be accessible?
Target Production Cost	How much should the product cost considering similar products? Is transportation of the product a significant portion of the cost?
Packaging	Is packaging required and are there any special packaging needs for protection, freshness, etc?
Quantity	What is the size of a production run? Will it be batch run or continuous manufacturing? Are current production facilities capable and will any production need to be contracted out?
Size and Weight	Between the product stages of production, transportation, storage, usage, and recycling; are there restriction on size and weight?
Aesthetic, look and feel	How should the consumer feel while using the product? What impressions are made through its use?
Materials	Are there special materials involved in production and use that will require consideration?
Manufacturing and Assembly	Are the desired methods of manufacturing and assembly currently within capability or is investment needed?

Translating Needs into Testable Requirements

What Is a *Design Specification*?

The Design Specification consists of a number of requirements (see figure 2.15). The design of a product is 'good' in so far as it complies with the stated requirements. A requirement is an objective that any design alternative must meet. The program of requirements is thus a list of objectives, or goals. Goals are images of intended situations, and consequently requirements are statements about the intended situations of the design alternative. Design alternatives should comply optimally with the requirements; an alternative which does not comply with one or more of the requirements is a bad alternative and cannot be chosen. Many requirements are specific; they apply to a particular product, a specific use, and a specific group of users. There are also requirements with a wider scope, as they are the result of an agreement within a certain branch of industry or an area of activity. Such a requirement is called a standard. To some extent, a designer is free to choose requirements; standards, however, are imposed by an external authority.

2. Distribution:

- 2.01 The electrical home scissors should be efficiently transported from producer to wholesale and/or small shops
- 2.02 The electrical home scissors be efficiently transported from wholesale or small shops to the consumer
- 2.03 The product may not be damaged during transportation and storage
- 2.04 The packaged product needs to be stackable
- 2.05 The displayed product should clearly communicate its function and possibilities

3. Use:

- 3.01 The product can be carried and hand-held
- 3.02 The electrical home scissors have to be ready for use in 1minute, preferably without use of any extra tool
- 3.03 The method of assembly of parts needs to be clear
- 3.04 The use of the electrical home scissors needs to be clear
- 3.05 Possible use restrictions of the electrical home scissors need to be clear
- 3.06 The operation of the product needs to be clear
- 3.07 The product needs to be operated standing and seated.
- 3.08 The product needs to be able to be used with one hand left and right handed
- 3.09 The product needs to resist a fall of 0.8m
- 3.10 The product may not damage the environment in which the product will be used
- 3.11 The product has to be designed in such a way that it will not harm users
- 3.12 The electrical home scissors need to be able to be cleaned with a wet tissue
- 3.13 Adjustments should be done by the user
- 3.14 The electrical home scissors need to be able to be repaired at a repair service

fig. 2.15 Example of a Design Specification (Criteria) (from student report)

Example of design specification

When Can You Make a Design Specification?

Normally, a design specification is constructed during the problem analysis, the result being some finished list of requirements. However, a design specification is never really complete. During a design project, even during the conceptual designing stages, new requirements are frequently found because of some new perspective on the design problem. Therefore, a design specification should be constantly updated and changed.

How to Make a Design Specification?

Starting Point The starting point for making a design specification is formed by the analyses that take place during the stage of problem analysis. **Expected Outcome** The outcome is a

structured list of requirements and standards. Programs consisting of 40 or 50 requirements are not uncommon.

Possible Procedure

1. List as many requirements as possible. Roozenburg and Eekels state that in order to arrive at a complete design specification, different points of view can be taken into account (see 'Checklists for Generating Requirements' in this section). Choose one, or several, of these points of views (stakeholders, aspects, or process tree) to help generate requirements. You can also use checklists, for example Pugh's checklist (see figure 2.14).
2. Make a distinction between hard and soft requirements (i.e. between quantifiable requirements and wishes).
3. Eliminate requirements which are in fact similar or which do not discriminate between design alternatives.
4. Identify whether there is a hierarchy in requirements. Distinguish between lower-level requirements and higher-level requirements.
5. Put requirements into practice: determine the variables of requirements in terms of observable or quantifiable characteristics.
6. Make sure that the program of requirements fulfils the following conditions:
 1. each requirement must be valid
 2. the set of requirements must be as complete as possible
 3. the requirements must be operational
 4. the set of requirements must be non-redundant
 5. the set of requirements must be concise
 6. The requirements must be practicable.

Tips and Concerns

- Be careful: do not make the possibilities for your design too limited by defining too many requirements.
- Distinguish between measurable requirements and non-measurable requirements.
- Give your requirements numbers in order to be able to refer to them.

References and Further Reading

Roozenburg, N.F.M. and Eekels, J. (1995) Product Design: Fundamentals and Methods, Utrecht: Lemma.

Roozenburg, N. and Eekels, J. (1998, 2nd ed.) Product Ontwerpen: Structuur en Methoden, Utrecht: Lemma.

Cross, N. (1989) Engineering Design Methods, Chichester: Wiley

ENGINEERING REQUIREMENTS

Requirements versus Specifications

Design specifications and engineering requirements are two types of documents that describe the desired features and characteristics of a product or system. However, they differ in their level of detail, scope and purpose.

Design specifications are usually broader and more general than engineering requirements. They address the “how” of the design, such as the materials, dimensions, functions and performance of the product or system. Design specifications may also include some non-technical aspects, such as aesthetics, ergonomics and usability. Design specifications are often used as a basis for developing engineering requirements.

Engineering requirements are more specific and precise than design specifications. They address the “what” of the design, such as the minimum and maximum values, tolerances, constraints and criteria that the product or system must meet. Engineering requirements are often derived from design specifications, customer needs, standards and regulations. Engineering requirements are usually written in a formal and standardized language, such as natural language with mathematical expressions or a modeling language.

The most important characteristic of an engineering requirement is that they must be **testable** (or falsifiable). If a requirement cannot objectively be determined to be satisfied or not, it is not properly written. The main task of the verification is developing and testing prototypes to understand if they satisfy requirements. In other words, engineering requirements are means by which we know if we have designed what we set out to design.

A properly formatted engineering requirement should have the following elements:

- A unique identifier, such as a number or a code. These are often hierarchical to indicate what aspect of the product the requirement relates.
- A subject, such as the name of the product or system component
- A predicate, such as a verb or an adjective that describes the desired state or behavior of the subject
- An object, such as a value, a unit, a condition or a reference that quantifies or qualifies the predicate
- A rationale, such as a reason or a justification for why the requirement is needed
- A verification method, such as a test, an analysis or an inspection that can be used to check if the requirement is met

For example, a properly formatted engineering requirement for a chair could be:

REQ-001: The chair shall support a static load of 150 kg without permanent deformation.

Rationale: To ensure safety and durability of the chair. Verification: Load test.

An improperly formatted engineering requirement for the chair could be:

The chair should be comfortable and sturdy.

This requirement is vague, subjective and unverifiable. It does not specify what constitutes comfort and sturdiness, how to measure them or what values are acceptable.

It is very common that a stakeholder need or design specification becomes multiple engineering requirements due to the need for the requirement to be clear, concise and specifically testable.

Example – Mechanical Pencil Requirement

Here is an example of an improperly worded engineering requirement for a mechanical pencil:

The mechanical pencil should be comfortable to use and should write smoothly for at least 100 pages before needing a new lead.

This requirement is improperly worded because:

- It uses the word “should” instead of “shall”. “Should” is subjective and indicates that the requirement is not mandatory, while “shall” is objective and indicates that the requirement is mandatory.
- The phrase “comfortable to use” is vague and difficult to test. There is no objective way to measure comfort, so it is not possible to determine whether or not the pencil meets this requirement.
- The phrase “write smoothly” is also vague and difficult to test. There is no objective way to measure smoothness, so it is not possible to determine whether or not the pencil meets this requirement.
- The requirement specifies that the pencil must write for at least 100 pages before needing a new lead. However, this requirement does not specify what type of paper the pencil will be used on or what type of lead will be used. The performance of the pencil may vary depending on these factors, so it is not possible to guarantee that the pencil will meet this requirement in all cases.

Here is an example of a properly worded engineering requirement for a mechanical pencil:

REQ-001: The mechanical pencil shall have a grip diameter of 10 mm and shall be able to write at least 100 pages of single-spaced text on standard 8.5" x 11" paper using a 0.5 mm HB lead without skipping or jamming.

This requirement is properly worded because:

- It uses the word “shall” to indicate that the requirement is mandatory.
- It is specific and precise, defining the grip diameter of the pencil, the type of paper that will be used, the type of lead that will be used, and the expected performance of the pencil.
- It is testable, as it is possible to measure the grip diameter of the pencil and to test the pencil’s performance on standard 8.5" x 11" paper using a 0.5 mm HB lead.

Try it yourself:

1. Write an intentionally poorly written requirement. Be sure to include words like “should” or “designed to”, vague untestable parameters and multiple dependencies.
2. Consider the most humorous way the requirement could be satisfied without actually satisfying the underlying customer need. For example: A car can meet a poorly written requirement for minimum acceleration by being dropped from a crane.
3. Rewrite your requirement to make it “fool proof”.

HOUSE OF QUALITY TOOL FOR NEEDS AND SPECIFICATION MANAGEMENT

The House of Quality (HOQ)

The House of Quality (HOQ) is a tool that helps designers relate and validate the connections between stakeholder needs and design specifications or engineering requirements. It is a matrix that shows the relationship between what the customers want and how the product can meet those wants. The HOQ also helps designers to compare their product with competitors and identify areas for improvement.

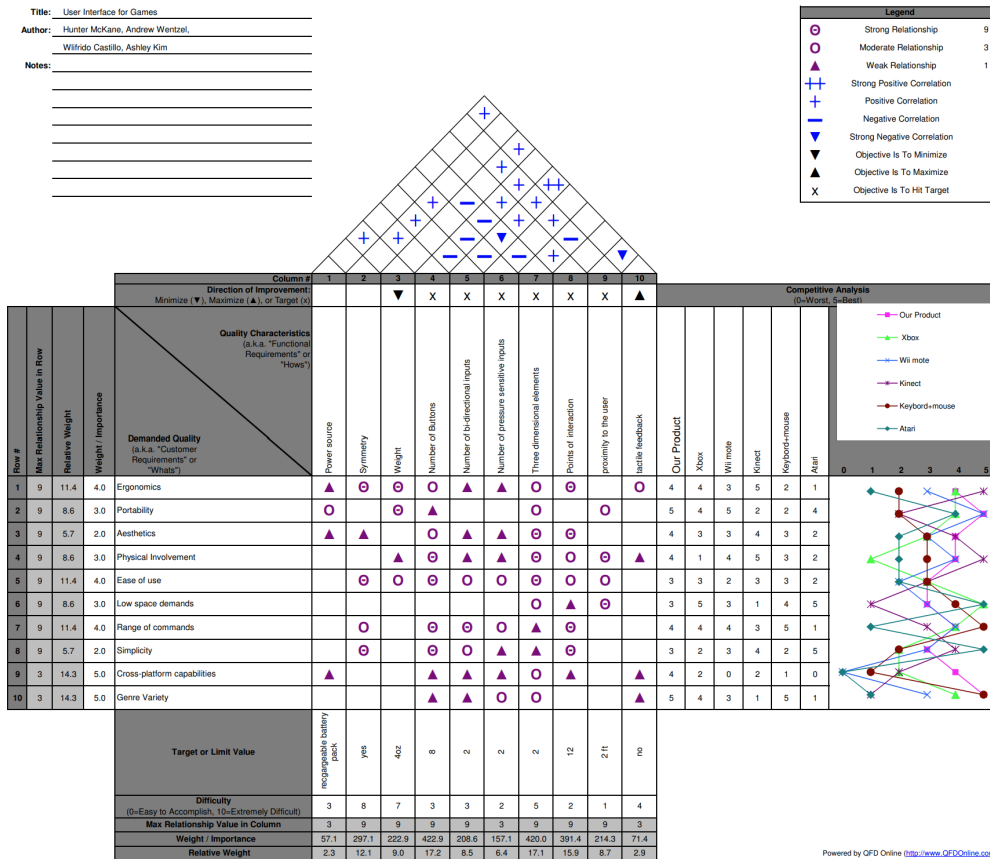

This is an example of completed house of quality for a game user interface.

An Excel-based Template is available from the following website (among many others as well).

QFD Online – Free House of Quality (QFD) Templates for Excel

The HOQ has six main parts:

– **Customer requirements:** These are the needs and expectations of the customers, expressed in their own words. This is sometimes called the “Voice of the Customer”

– **Engineering characteristics:** These are the measurable attributes of the product that affect its performance and quality. They can be derived from technical standards, specifications, regulations, etc.

– **Relationship matrix:** This is the core of the HOQ, where the customer requirements and engineering characteristics are linked. Each cell in the matrix indicates how strongly an engineering characteristic affects a customer requirement. The strength of the relationship can be rated using symbols, numbers, or colors.

– **Correlation matrix:** This is a smaller matrix at the top (or roof) of the HOQ, where the engineering characteristics are compared with each other. Each cell in the matrix shows how positively or negatively two engineering characteristics correlate. The correlation can be indicated using symbols, such as +, -, or 0.

– **Competitive assessment:** This is a section at the bottom of the HOQ, where the product is evaluated against its competitors based on the customer requirements and engineering characteristics. The evaluation can be done using symbols, such as \circ , Δ , or \times , or numbers, such as 1 to 5.

– **Technical assessment:** This is a section at the right of the HOQ, where the engineering characteristics are prioritized based on their importance and difficulty. The importance can be calculated by multiplying the relationship matrix ratings by the customer requirements weights. The difficulty can be estimated by considering factors such as cost, time, feasibility, etc.

The process for filling out the HOQ can be summarized as follows:

1. Define the scope and objective of the design project.
2. Identify and prioritize the customer requirements using various methods and sources.
3. Identify and define the engineering characteristics that can satisfy the customer requirements.
4. Fill in the relationship matrix by rating how each engineering characteristic affects each customer requirement.
5. Fill in the correlation matrix by rating how each engineering characteristic correlates with each other.
6. Fill in the competitive assessment by evaluating how the product and its competitors perform on each

customer requirement and engineering characteristic.

7. Fill in the technical assessment by calculating the importance and estimating the difficulty of each engineering characteristic.
8. Analyze and interpret the results of the HOQ and use them to guide further design decisions and actions.



One or more interactive elements has been excluded from this version of the text. You can view them online here: <https://uark.pressbooks.pub/mechanicaldesign/?p=105#oembed-1>

Instructions for Completing a House of Quality



One or more interactive elements has been excluded from this version of the text. You can view them online here: <https://uark.pressbooks.pub/mechanicaldesign/?p=105#oembed-2>

Industry Interview – What is Voice of the Consumer and How is it Used?

WRAP UP - DEFINING AND MANAGING DESIGN REQUIREMENTS

Summary of Concepts

This chapter discussed the process of developing, defining, and managing design requirements. Starting from identifying the customer needs and translating them into testable design requirements. It explained the importance of understanding the problem context, the stakeholders, and the functional and non-functional aspects of the product. It also presented various methods and tools for eliciting, analyzing, and prioritizing customer needs, such as interviews, surveys, focus groups, QFD, and Kano model. It then showed how to formulate design requirements that are clear, measurable, and consistent with the customer needs and the design specifications.

Questions



An interactive H5P element has been excluded from this version of the text. You can view it online here:

<https://uark.pressbooks.pub/mechanicaldesign/?p=290#h5p-4>

PART V

CONCEPTUAL DESIGN PROCESS AND TOOL

Learning Objectives

This part focuses on beginning the conceptual design stage. Specifically, we will discuss methods of creatively exploring and generating a large set of diverse potential solutions. A management technique for organizing solutions and some techniques for evaluating and selecting concepts once a large pool of them has been generated. At the end of this part students will be able to:

- Identify several methods and best practices for creative concept generation
- Utilize a morphological matrix to manage and generate solution
- Develop a diverse set of concepts that satisfy all functional requirements of a product
- Utilize a Pugh chart to semi-objectively compare different concepts against criteria to make rational down-selection choices

Introduction

The following text is from the Delft Design Guide.

Daalhuizen, Jaap. 2018. Delft Design Approach, Delft University of Technology.

After the phase of problem analysis, the conceptual design phase begins. Conceptual designing means the creative act of thinking up product ideas and concepts. Once a design problem, requirements and a product vision have been formulated, product ideas and concepts have to

be generated. An idea is a first thought that comes to mind, usually in the form of a simple drawing, without dimensions, proportions, shape and materials. Concepts are more developed, have materials, dimensions, shape, details and technical solution principles. Conceptual design is a process of creative thinking, of developing initial ideas into concepts and offering realistic solutions to the design problem. It is a divergent and convergent process in which ideas are generated, tested and evaluated and developed into concepts. Ideas are generated by means of creativity techniques, such as brainstorming or Synectics. In your evaluation of ideas, you bear in mind the design goal and the design specification. Visualizing is an important aspect in the creative phase of designing: often you explore early ideas by means of sketches. Three-dimensional models such as sketch models, mock-ups and prototypes are also used. Such representations of ideas can be used for simulation and for testing the ideas and concepts.

CREATIVITY TECHNIQUES

A Word about Creativity

Research shows that, on average, the more schooling one has the less creative they are on divergent thinking scores. See this for example. Unfortunately, you have had a lot of school to get to this point! However, creativity is NOT an inherent property of some people and not others. Research continues to show that being creative and innovative are learnable skills. Do not sell yourself short. But also, be prepared to work hard if you want to become more creative!



One or more interactive elements has been excluded from this version of the text. You can view them online here: <https://uark.pressbooks.pub/mechanicaldesign/?p=109#oembed-1>

The following text is from the Delft Design Guide.

Daalhuizen, Jaap. 2018. Delft Design Approach, Delft University of Technology.

What Are Creativity Techniques?

The techniques for thinking up solutions to problems are called 'creativity techniques' or 'creativity methods'. Most of these methods are general – they are applicable to a wide variety of problems. Creativity techniques are very useful in the design process, generating large amounts of ideas in a short time. There are many different creativity techniques, often classified according to structures like the following one (see Marc Tassoul, 2007):

Inventorying techniques: Techniques used to collect and recall all kinds of information

around an issue. This helps in making an inventory of what we have in terms of ideas, or data, or whatever. Examples are Mind Maps (see 'Mind Map' in this section).

Associative Techniques: With associative techniques, great numbers of ideas and options are generated through association within a relatively short time. Association techniques encourage spontaneous reactions to ideas expressed earlier. An example of an associative technique is the brainstorming method (see 'The Brainstorming Method' in this section)

Confrontational Techniques: With confrontational techniques, ideas are generated by thinking outside one's familiar frame of reference. By identifying and breaking assumptions, you are able to open up a wider solution space. New connections are made between the original issues in hand and a new idea through bisociation or force-fit. Completely new, unexpected combinations of viewpoints can arise, which bring the solution of the problem one step closer.

Provocative Techniques: With provocative techniques, assumptions and preconceptions are identified and broken from inside the familiar frame of reference (e.g. by asking questions like: "What if not?" and "What else?"). Provocative techniques make use of analogies, metaphors and random stimuli. Ideas will seem strange at first, but when force-fitted on the original issues they provoke new insights. Both confrontational and provocative techniques contain the principle of (1) making the strange familiar and (2) the familiar strange.

Intuitive Techniques: With intuitive techniques you develop a vision, or a new perspective on the original issue in hand. Intuitive techniques are useful for letting go: to guide the idea generation techniques by whatever comes to mind. It is a technique that allows for spontaneous and intuitive idea generation and reflecting upon the generated ideas. These techniques have a great influence on enthusiasm, motivation and courage of the team members.

Analytic-Systematic Techniques: Analytic-systematic methods are based on the analysis and systematic description of a problem, the drawing up of an inventory of solutions, variants to subproblems, and the systematic varying and combining of these solution variants. The morphological method and function analysis are the most typical examples (see 'Function Analysis' and 'Morphological Chart' in this section). Creative Problem Solving In order to apply the various creativity techniques effectively, a creative process needs to be followed. A very simple model of the creative process is provided by Wallas (1926): (1) preparation, (2) incubation, (3) illumination, and (4) verification. In the preparation phase the problem is defined. During the incubation phase, the issue is let go and attention is focused on other (inspirational) aspects. In the illumination phase an opening is (suddenly) found, from which an approach is developed to deal with the issue in hand. During the verification phase the idea is tested and evaluated.

Tassoul and Buijs (2005) have modelled the creative problem-solving process in a more elaborate model, called the CPS model revisited (see figure 2.18). This model consists of three phases: (1) problem statement, (2) idea generation, and (3) concept development.

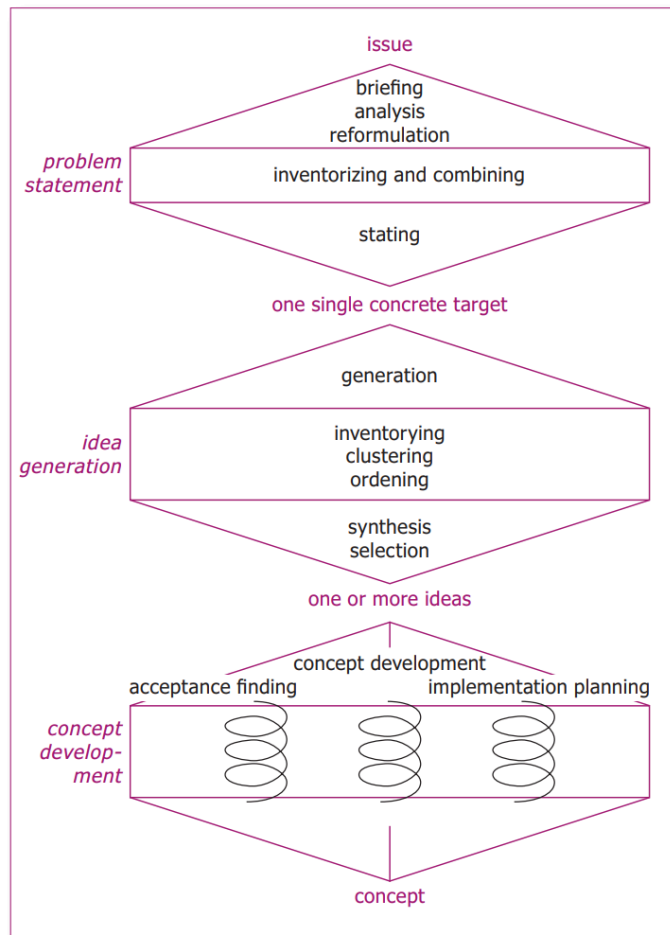

fig. 2.18 CPS model revisited of the Creative Problem Solving Process (Tassoul and Buijs, 2005)

Model of Creative problem solving

When Can You Use Creativity Techniques?

Creativity techniques are mostly used in a creative workshop, or in a brainstorm setting typically taking place at the beginning of the conceptual design phase, starting the phase of creating product ideas and concepts.

References and Further Reading

Tassoul, M. (2006) Creative Facilitation: a Delft Approach, Delft: VSSD.

Roozenburg, N.F.M. and Eekels, J. (1995) Product Design: Fundamentals and Methods, Utrecht: Lemma.

Roozenburg, N. and Eekels, J. (1998, 2nd ed.) Product Ontwerpen: Structuur en Methoden, Utrecht: Lemma.

Wallas, G. (1926, 1970) 'The art of thought', In: Vernon, P.E. (ed.) Creativity, Harmondsworth: Penguin.

TOOLS FOR SUPPORTING CREATIVE DESIGN SOLUTIONING

The following text is from the Delft Design Guide.

Daalhuizen, Jaap. 2018. Delft Design Approach, Delft University of Technology.

Mind Map

A Mind Map is a graphical representation of ideas and aspects around a central theme, showing how these aspects are related to each other. With a Mind Map you can map all the relevant aspects and ideas around a theme, bringing structure, overview and clarity to a problem. A Mind Map helps in systematically unpacking abstract thoughts and notions. It is like a tree, with branches leading to the thoughts and aspect of the theme. Graphically, one can use the analogy of the tree by making branches that are important thicker than others. Mind Mapping is an excellent technique for developing your intuitive capacity. It is especially useful for identifying all the issues and subissues related to a problem. Mind Maps can also be used for generating solutions to a problem and mapping their advantages and disadvantages. The latter is accomplished by making the main branches the solutions and the subbranches from each of these the pros and the cons. Analyzing the Mind Map helps you find priorities and courses of action.

When Can You Use a Mind Map?

A Mind Map can be used in different stages of the design process but is often used in the beginning of idea generation. Setting up a Mind Map helps you to structure thoughts and ideas about the problem and connect these to each other. However, a Mind Map can also be used in the problem analysis phase of a design project. Mind Maps also work well for outlining presentations and reports. In fact, Mind Mapping can be used in a wide variety of situations.

How to Use a Mind Map?

Starting Point

The starting point of a Mind Map is a central theme, for example a problem or an idea.

Expected Outcome

The outcome of a Mind Map is a structured overview of ideas and thoughts around a concept or a problem, represented graphically.

Possible Procedure

1. Write the name or description of the theme in the center of a piece of paper and draw a circle around it.
2. Brainstorm each major facet of that theme, placing your thoughts on lines drawn outward from the central thought like roads leaving a city.
3. Add branches to the lines as necessary.
4. Use additional visual techniques – for example, different colors for major lines of thought, circles around words or thoughts that appear more than once, connecting lines between similar thoughts.
5. Study the Mind Map to see what relationships exist and what solutions are suggested.
6. Reshape or restructure the Mind Map if necessary.

Tips and Concerns

- You can find software for Mind Mapping on the Internet. The disadvantages of using computer software are that there is some limitation in freedom of using hand drawings and colors, it is less personal, and it might be less suitable when sharing it with others (you and your computer alone).
- Make digital pictures of your handmade Mind Maps



One or more interactive elements has been excluded from this version of the text. You can view them online here: <https://uark.pressbooks.pub/mechanicaldesign/?p=111#oembed-1>

The Brainstorming Method

What Is the Brainstorming Method?

When people hear the word brainstorming they often think of people sitting together and thinking up ideas wildly and at random. This is partly true! Brainstorming as a method prescribes a specific approach with rules and procedures for generating ideas. It is one of many methods used in creative thinking to come up with lots of ideas to solve a problem. Various methods or approaches to creativity exist, such as: brainstorming, synectics, lateral thinking/random stimulus and biomimetics. Brainstorming was invented by Osborn as early as the 1930s. Apart from producing large numbers of ideas, brainstorming is based on another very important principle: the avoidance of premature criticism. Of course ideas must be assessed critically, but an all too critical attitude often holds back the process of generating ideas. We follow the brainstorm method of Osborn (1953) and Parnes (1992). This method consists roughly of the following steps:

1. Diverging from the problem. Beginning with a problem statement, this first stage is about a “creative démarche”: a creative path where lots of ideas are generated using different techniques. Wild and unexpected ideas are welcomed.
2. Inventorying, evaluating and grouping ideas. The second step is about evaluating, reviewing and grouping ideas. Now an overview is created of the solution space (e.g. all possible solutions) and whether more ideas are needed.
3. Converging: choosing a solution. The third step is about choosing ideas and selecting ideas for the next phase in the design process.

The process underlying this method is built upon the following assumptions:

1. Criticism is postponed. The participants in a brainstorming session should try not to think

of utility, importance, feasibility and the like, and certainly not make any critical remarks thereon. This rule should not only lead to many, but also to unexpected associations. Also, it is important to avoid participants feeling attacked.

2. 'Freewheeling' is welcomed. The purpose is to have participants express any idea they think of; 'the wilder the idea, the better', it is said. In a brainstorming session an atmosphere must be created which gives the participants a feeling of safety and security.
3. Combination and improvement of ideas are sought. You should endeavour to achieve better ideas by adding to, and building upon, the ideas of others.
4. Quantity is wanted. Try to think of as many associations as possible. The objective of this rule is to attain a high rate of association. The underlying idea is not only that 'quantity breeds quality' but also that through a rapid succession of associations the participants have little chance of being critical.

Brainstorm Session

Brainstorming (see figure 2.24) is done with a group consisting of 4-8 people. A facilitator leads the brainstorm session and asks the group provocative questions. The group's responses (the ideas) are written down on a flip-chart. The stages that the group goes through in a brainstorm session are methods on their own, and different alternative methods are possible within a brainstorm session (for example: how to's, who-what-where-when-why-how, forward and backward planning, and wishful thinking).



fig. 2.24 Brainstorm session (Tassoul, 2007)

An example brainstorming session using sticky notes.

Brainwriting Session

Brainwriting is done with a group consisting of 4-8 people. A facilitator leads the Brainwriting session and asks the group provocative questions. Each participant writes down his/ her idea on a piece of paper, and the papers are passed on to each other. In this way, an idea is elaborated when it passes through numerous participants, or an idea could serve as an inspiration for new ideas. Different versions of this method are possible. A well-known method is the 6-5-3 method.

Braindrawing Session

In a Braindrawing session (see figure 2.25) ideas are not written down but are drawn or sketched. This distinguishes Braindrawing from brainstorming, which only uses words. In a Braindrawing session each participant draws his/her ideas on paper. Also, it is possible to build on each other's ideas by passing through the drawings similar to a Brainwriting session.



fig. 2.25 Braindrawing session

Example Brain drawing session.

When Can You Use the Brainstorming Method?

A brainstorm is usually carried out in the beginning of the idea generation, with the goal of producing a large number of ideas with a group of participants.

How to Use the Brainstorming Method?

Starting Point

The starting point of a brainstorm session is a problem statement (one single concrete target).

Expected Outcome

The outcome of a brainstorm session is a large number of ideas.

Possible Procedure

1. Develop a statement of the problem (e.g. with H2's, one single concrete target) and select a group of 4-8 participants. Draw up a plan for the brainstorm session, including a detailed timeline, the steps written down, and the methods used in the brainstorm session (example of a session plan

2. You could send a note containing the statement of the problem, background information, examples of solutions and the four brainstorming rules, to the participants some time before the session.
3. Have a preparatory meeting together with the participants, right before the actual brainstorm session, whereby the method and rules are explained, the problem, if necessary, is redefined, and a so-called warm-up is held. A warm-up is a short stimulating brainstorming exercise unrelated to the problem.
4. At the beginning of the actual brainstorm session, write the statement of the problem on a blackboard or flip chart clearly visible to everyone, as well as the four rules.
5. The facilitator should ask provocative questions to the group and write down the responses on a flip chart.
6. Once a large number of ideas has been generated, the group should make a selection of the most promising and interesting ideas. Usually, some criteria are used in the selection process, which should be established with the group.



One or more interactive elements has been excluded from this version of the text. You can view them online here: <https://uark.pressbooks.pub/mechanicaldesign/?p=111#oembed-2>

Tips and Concerns

- Brainstorming is suited for solving relatively simple problems with an 'open' formulation. For more complex problems, it would be possible to brainstorm about subproblems, but then the overall view might be lost. Furthermore, brainstorming is not suited very well for problems whose solution requires highly specialized knowledge.

References and Further Reading

Roozenburg, N.F.M. and Eekels, J. (1995) Product Design: Fundamentals and Methods, Utrecht: Lemma.

Roozenburg, N. and Eekels, J. (1998, 2nd ed.) Product Ontwerpen: Structuur en Methoden, Utrecht: Lemma.

Tassoul, M. (2006) Creative Facilitation: a Delft Approach, Delft: VSSD.

Higgins, J.M. (1994) 101 Problem Solving Techniques, New York: New Management Publishing Company

FUNCTIONAL ANALYSIS

The following text is from the Delft Design Guide.

Daalhuizen, Jaap. 2018. Delft Design Approach, Delft University of Technology.

What Is a Function Analysis?

Function analysis is a method for analyzing and developing a function structure. A function structure is an abstract model of the new product, without material features such as shape, dimensions and materials of the parts. It describes the functions of the product and its parts and indicates the mutual relations. The underlying idea is that a function structure may be built up from a limited number of elementary (or general) functions on a high level of abstraction. Functions are abstractions of what a product should do. Being forced to think about the product in an abstract way stimulates creativity, and prevents you from ‘jumping to solutions’, i.e. immediately elaborating on the first idea that comes to mind, which may not be the best.

In function analysis, the product is considered as a technical-physical system. The product functions, because it consists of a number of parts and components which fulfil subfunctions and the overall function. By choosing the appropriate form and materials, a designer can influence the subfunctions and the overall function. The principle of function analysis is first to specify what the product should do, and then to infer from there what the parts – which are yet to be developed – should do. Function analysis forces designers to distance themselves from known products and components in considering the question: what is the new product intended to do and how could it do that? The method is useful to accomplish a breakthrough in thinking in conventional solutions.

A function analysis often precedes the morphological method (see ‘Morphological Chart’ in this section). The functions and subfunctions that are identified in the function analysis serve as the parameters in the morphological chart.

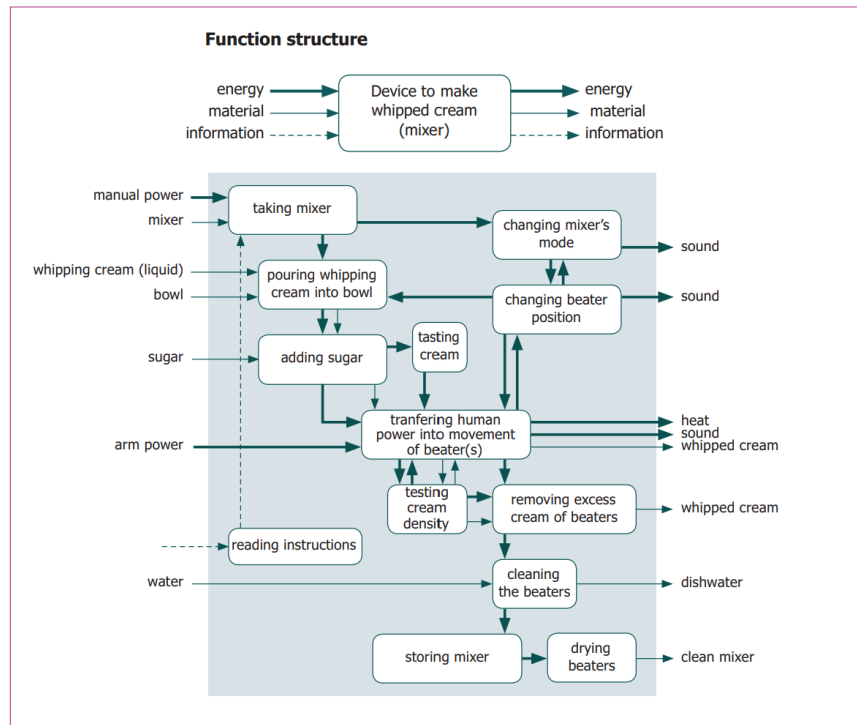

Example functional model from a student project.

When Can You Use a Function Analysis?

A function analysis is typically carried out at the beginning of idea generation.

How to Use a Function Analysis?

Starting Points

There are two possible starting points, which may be used in a combined form:

- A process tree, which can be drafted from scratch or based on an existing solution of the design problem (or a comparable problem)
- A collection of elementary (general) functions, for instance the functional basis developed by the American National Institute of Standards and Technology (NIST).

Expected Outcome

The outcome of the function analysis is a thorough understanding of the functions and subfunctions that the new product has. From functions and subfunctions the parts and components for the new product can be developed, for instance by using them as input for the creation of a morphological chart.

Possible Procedure

1. Describe the main function of the product in the form of a black box. If you cannot define one main function, go to the next step.
2. Make a list of subfunctions. The use stage of a process tree is a good starting point. By adding extra columns to the process tree in which you distinguish between product functions and user tasks, you can make a first list of functions.
3. Just like the processes in a process tree, functions are based on verb-noun combinations. Only those processes that are carried out by the product are functions; processes performed by the user are user tasks. For user tasks, you can often define functions that support the user in performing the task. For instance, for a user task lift product a supporting function would be provide grip for lifting.
4. For a complex product, you may want to develop a function structure. There are three principles of structuring: putting functions in a chronological order, connecting inputs and outputs of flows between functions (matter, energy and information flows) and hierarchy (main functions, subfunctions, subsubfunctions, etc.). These principles cannot always be applied – see the last item of Tips and Concerns. To visualize the chronological order, you can simply list the functions. To visualize the flows, you can connect boxes by arrows. To visualize hierarchy, you can draw a tree structure (just like the process tree) so that you can combine hierarchy with chronological order, or you can draw boxes-in-boxes, so that you can combine hierarchy and flows in one diagram.
5. Elaborate the function structure. Fit in a number of 'auxiliary' functions which were left out and find variations of the function structure so as to find the best function structure. Variation possibilities include moving the system boundary, changing the sequence of subfunctions and splitting or combining functions. Exploring various possibilities is the essence of function analysis: it allows for an exploration and generation of possible solutions to the design problem.



One or more interactive elements has been excluded from this version of the text. You can view them online here: <https://uark.pressbooks.pub/mechanicaldesign/?p=113#oembed-1>

Tips and Concerns

- If you have a function structure, it is recommended you develop variants of it. A statement of a problem never leads imperatively to one particular function structure. The strength of function analysis lies in the possibility of creating and comparing, at an abstract level, alternatives for functions and their structuring.
- Certain subfunctions appear in almost all design problems. Knowledge of the elementary or general functions helps in seeking product-specific functions.
- The development of a function structure is an iterative process. There is nothing against starting by analysing an existing design or with a first outline of an idea for a new solution. However, in the course of the analysis you should abstract from it.
- Function structures should be kept as simple as possible. The integration of various functions into one component (function carrier) is often a useful means in this respect.
- Block diagrams of functions should remain conveniently arranged; use simple and informative symbols. Be aware of different types of functions.
- In industrial design engineering and product design, it is not always possible to apply structuring principles. The principles have their background in mechanical engineering, where functions describe machines processing raw materials in steps to produce products. Don't worry: an unstructured list of (sub)functions is better than no function descriptions at all.

References and Further Reading

Roozenburg, N.F.M. and Eekels, J. (1995) *Product Design: Fundamentals and Methods*, Utrecht: Lemma.

Roozenburg, N. and Eekels, J. (1998, 2nd ed.) *Product Ontwerpen: Structuur en Methoden*, Utrecht: Lemma.

Cross, N. (1989) *Engineering Design Methods*, Chichester: Wiley.



MORPHOLOGICAL CHART

The following is an excerpt from the Delft Design Guide.

Daalhuizen, Jaap. 2018. Delft Design Approach, Delft University of Technology.

What Is a Morphological Chart?

The morphological chart (see figure 2.32) is a method to generate ideas in an analytical and systematic manner.

Usually, functions of the product are taken as a starting point. The various functions and subfunctions of a product can be established through a function analysis (see 'Function Analysis' in this section). However, function analysis does not guarantee that all the relevant (sub) functions are identified. Often a number of solutions to these (sub) functions are already known, while others are thought up by yourself. These solutions will form the components in the morphological chart. The morphological method thus yields a matrix of functions and components. Possible components are listed on the basis of their functions. The components are concrete and specific, specifying the elements that belong to a category (i.e. parameter). These components are already known partially from existing solutions: analogous products. Functions are listed in columns, and components are the means that realize the functions and are listed in rows.

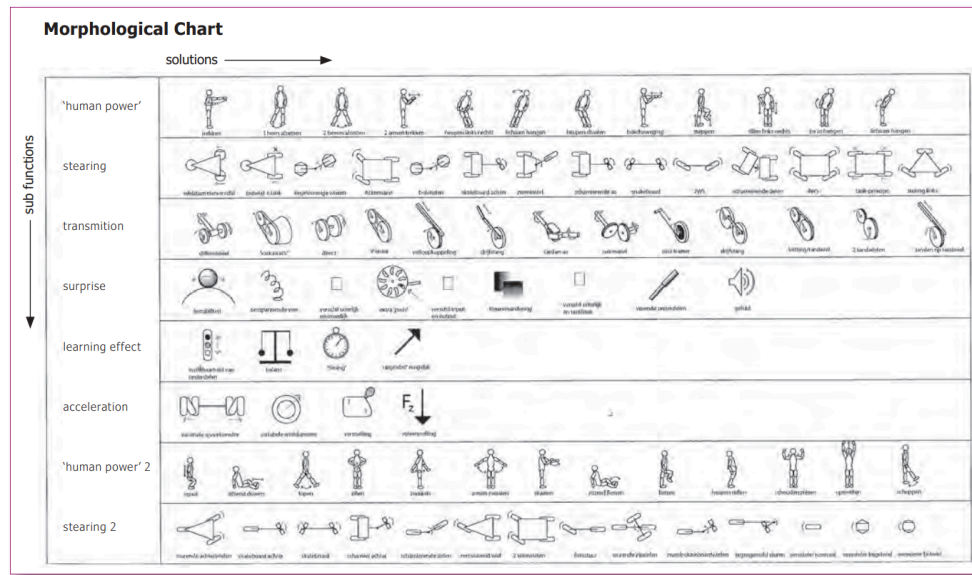

An example of a morphological matrix

The parameters are identified by focusing on the commonalities of components and describing them as the characteristics which a product should have, thus indicating what the product should be; they are essential to the solution. The parameters are independent and abstract and indicate a category (with no reference to material features). By means of the morphological chart, the product's purpose is split into a set of (sub)functions. For each of the (sub)functions ideas are generated and combined into an overall solution. Through careful selection and combination of a set of components, an idea comes about. This idea should be seen as a principal solution: a carefully chosen combination of components that together form a conceptual solution.

New components are found by making the abstract parameters concrete through the establishment of technical principles. In this way, the morphological method is an evolutionary method: parameters and components are evolved in parallel until the final morphological chart is made.

In the end, solution principles are found by choosing one component from each parameter. In other words, each combination of components (one component being selected from each parameter) suggests a solution to the problem. The generation of solutions is thus a process of systematically combining components.

However, the larger the morphological matrix, the larger the amount of possible solutions (theoretically, a 10 x 10 matrix yields 10,000,000,000 solutions), which takes much time to evaluate and choose from. In order to limit the number of options, two evaluation strategies are helpful: (a) analysis of the rows and (b) grouping of parameters.

1. a) Analysis of the rows is based on rank ordering the components per parameter in a first and second preference. The rank ordering is done against (a part of) the criteria or design requirements. Using only the first and second preferences brings down the number of components and thus reduces the number of solutions.
2. b) The second evaluation strategy is grouping the parameters in groups of decreasing importance. As a first step, only the most important group of parameters is evaluated. After one or more combinations of components have been chosen, only these are involved in the evaluation.

When Can You Use a Morphological Chart?

The morphological chart is usually applied in the beginning of idea generation. Function analysis is used as a starting point. Not all design problems are suitable for using the morphological method. The morphological chart has been successful in particular for design problems in the field of engineering design.

How to Use a Morphological Chart?

Starting Point

The starting point of a morphological chart is a well defined design problem. A function analysis of the product that needs to be designed forms another starting point: the product should be described in terms of function and subfunctions.

Expected Outcome

The expected outcome of the morphological method is a number of principal solutions (consisting of components) for the initial design problem.

Possible Procedure

1. The problem to be solved must be formulated as accurately as possible.
2. Identify all the parameters which might occur in the solution (i.e. functions and subfunctions).
3. Construct a morphological chart (a matrix), with parameters as the columns.
4. Fill the rows with the components that belong to that particular parameter. Components can be found by analysing similar products or thinking up new principles for the parameters (functions).
5. Use the evaluation strategies (analysis of rows and grouping of parameters) to limit the number of principal solutions.
6. Create principal solutions by combining at least one component from each parameter.
7. Carefully analyse and evaluate all solutions with regard to (a part of) the criteria (design requirements), and choose a limited number of principal solutions (at least 3).
8. The principal solutions selected can be developed in detail in the remaining part of the design process.

Tips and Concerns

- When a combination of components has yielded a principal solution, be sure to draw all the components when developing the solution principle in sketches.
- You may be tempted to choose the 'safe' combinations of components. Challenge yourself by making counter-intuitive combinations of components.
- Do not describe the components in words, but use pictograms or symbols to indicate them.

References and Further Reading

Roozenburg, N.F.M. and Eekels, J. (1995) *Product Design: Fundamentals and Methods*, Utrecht: Lemma.

Roozenburg, N. and Eekels, J. (1998, 2nd ed.) *Product Ontwerpen: Structuur en Methoden*, Utrecht: Lemma.

Cross, N. (1989) *Engineering Design Methods*, Chichester: Wiley

Using a Morphological Chart to Synthesizing Complete Concepts

A morphological chart captures many subsolutions to each function. A *Complete Concept Solution* is generated by synthesizing subfunctions together. You can do this by selecting one or more solution from each row and generating a sketch with each individual sub solution. Then, you will need to make sure the flows between subsolutions are logical and consistent. For example, if two subsolutions are controls knobs (for allow control) and heating elements (for provide thermal energy), synthesis of these two solutions implies some sort of electrical control board and wiring system.

Process

o synthesize subsolution concepts in a morphological chart to develop complete product concept solutions, follow these steps:

1. **Identify the main functions of the product.** What are the essential tasks that the product must perform?
2. **Break down each main function into subfunctions.** What are the smaller tasks that need to be accomplished in order to achieve the main function?
3. **Identify all possible subsolutions for each subfunction.** This can be done through brainstorming, research, and analysis.
4. **Create a morphological chart.** List the subfunctions down the left side of the chart and the subsolutions for each subfunction across the top.
5. **Generate new product concepts by combining subsolutions from different columns.** Consider all possible combinations, even if they seem unusual or impractical at first.
6. **Evaluate the new product concepts.** Consider the feasibility, cost, and performance of each concept. Select the most promising concepts for further development.

Here is an example of how to use a morphological chart to synthesize subsolution concepts to develop complete product concept solutions:

Morphological chart:

Subfunction	Heat water	Grind coffee beans	Brew coffee grounds	Keep coffee hot	Dispense coffee
Heat water	Electric	Gas	Induction		
Grind coffee beans	Blade grinder	Burr grinder			
Brew coffee grounds	Drip brewing	French press	Espresso machine		
Keep coffee hot	Carafe	Thermal pot	Heating plate		
Dispense coffee	Manual	Automatic			

New product concepts:

- Electric powered with blade grinder that feeds a drip coffee maker that pours into a thermal pot
- Gas powered with a burr grinder style grinder that feeds a French press and excess heat is used for the heating plate
-

These are just a few examples of new product concepts that can be generated using a morphological chart. By combining subsolutions from different columns, it is possible to generate a wide range of new and innovative concepts. To build these into complete solutions, you need to identify how the energy and materials will be flowing through the system.

Here are some additional tips for using a morphological chart to synthesize subsolution concepts to develop complete product concept solutions:

- Be creative and don't be afraid to explore unusual or impractical combinations at first.
- Collaborate with others to develop more complete morphological charts.
- Be sure to sketch out complete solutions and include annotations in order to make sure you don't forget a concept.
- Push yourself to make as many complete concepts as possible. Perhaps your next idea will be the best!

This is a similar approach to using morphological chart.



One or more interactive elements has been excluded from this version of the text. You can view them online here: <https://uark.pressbooks.pub/mechanicaldesign/?p=115#oembed-1>

DECISION AND SELECTION

The following is an excerpt from the Delft Design Guide.

Daalhuizen, Jaap. 2018. Delft Design Approach, Delft University of Technology.

Design is a process of diverging and converging. The design of a product grows from a product idea via solution principles, concepts and preliminary designs to a detailed definitive design. Design is also a process of working from a large number of ideas to a single detailed design. Designing without intuitive decisions is inconceivable. But for new, complex or unknown decision problems, intuitive decision-making is not always successful. Decision methods aim to help people in making a decision.

In decision methods, you compare alternatives on predefined criteria. You look at how well an alternative performs 'on the criteria' and assign a value to this performance. By bringing together the totality of the values of each of the criteria, you calculate an overall score of the alternative. Calculating the overall scores of each of the alternatives and comparing the alternatives facilitates a decision-making process. This is what decision methods are about.

The manner in which the overall score of an alternative is calculated is called the value function, or decision rule. However, these functions and rules are full of fallacies and pitfalls. Therefore, in using a certain method, you should really see whether the specific decision problem does indeed answer those assumptions, for only then does it make sense to use this method. Decision methods do not guarantee a sound answer! They are mere aids in the process of coming to a sound and wellconsidered decision.

The decision-maker should always reflect on the verdicts/decisions reached, bearing in mind the initially stated goals and aims of the projects.

Datum Method

What Is a Datum Method?

The Datum Method (see figure 2.61) is a method for evaluation of design alternatives. One of the alternatives is set as datum to which the other alternatives are compared for a range of criteria. Three judgements can be given: 'worse', 'same' or 'better' expressed in '-', '0' and '+'. The sum of each of these three values will then help to make a decision. The value of the alternatives is guessed on the basis of the 'intuitive' judgements of the decision-makers.

The method aims to provide the decision-makers with confidence through a systematic discussion of the criteria and by eliciting the advantages and disadvantages of the alternatives.

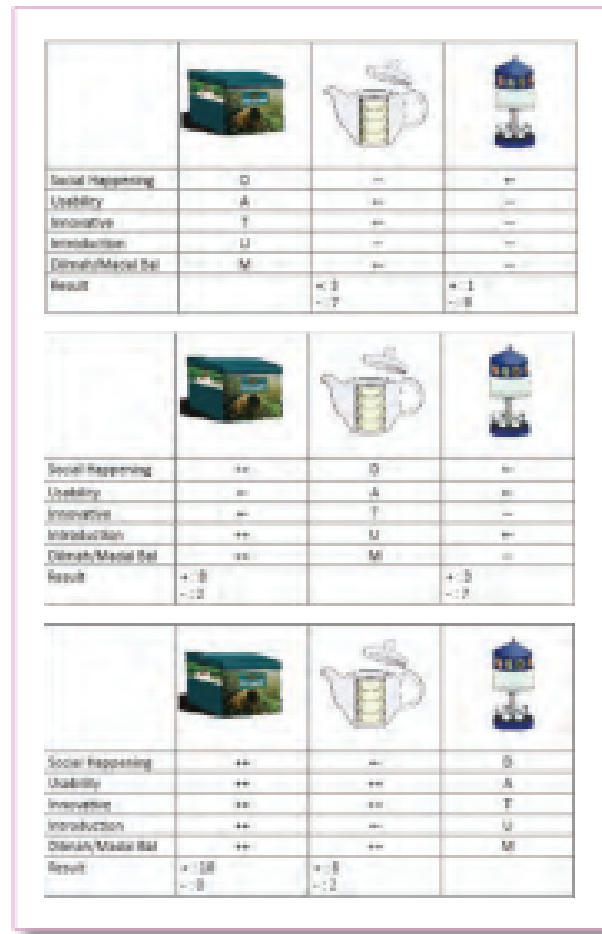

Fig. 2.61 Example of Datum Method (from student report)

Example datum chart from student project.

When Can You Use a Datum Method?

Whenever a number of alternatives of a product concept need to be compared to reach consensus in the evaluation or to make an intuitive decision, the Datum Method can be used. Although it can be used throughout the whole design process, commonly it is used to select concepts.

How to Use a Datum Method?

Starting Point

Product concepts, developed to an equal, and thus comparable, level of detail. A list of criteria suitable for use in this stage and in relation to the level of detail.

Expected Outcome

One or more strong concepts for further development, confidence in the decision for the chosen concept(s). More understanding of the value of all the concepts, more insight in the problems still to be solved and a simple matrix to discuss with others and convince third parties.

Possible Procedure

1. Arrange the concepts and criteria in a matrix (see figure 2.61).
2. Choose one of the concepts as 'datum'. Compare the other concepts to this datum and give a score for each criterium at the time (+ = better than datum, - = worse than datum and s = similar/same).
3. Indicate $\sum+$, $\sum S$ and $\sum-$ for each concept. Usually at least one concept will show more '-' and less '+'. Usually a few concepts have minor differences. Discussion can start. An equal spread of pluses, minuses and similars indicates vague and ambiguous criteria.
4. When the outcome does not distinguish enough, the process should be repeated until it does. Each time another concept should be taken as datum, leaving out the concept which was definitively worse.

Tips and Concerns

- Sometimes the designer will not only totalise the score in $\sum+$, $\sum S$ and $\sum-$, but also adds up the totals. Like each '+' for one particular concept is compensated by each '-' given to the same concept. A concept with two '+', one 'S' and two '-' will have an end score of zero (0). Although it is a way to have some outcome, one must realise that this will fade away the results and doesn't help to discuss the concepts or criteria. Another concept might score zero (0) also, thus leading to the assumption that both concepts are equal, while

the second concept initially scored one '+', three 'S' and one '-'. It all depends on the weight of each criterion and the possibility to change a '-' into 'S' or '+' by redesign. The method is therefore not to be seen as a sort of mathematically justified process, but as an aid to the decision making.

- Another aspect is the selection of criteria. Usually there are a lot of criteria to which the concepts do not comply to, yet. A criterion stating that the product should cost no more than 15 Euro's, or weigh max 800 grams, cannot be judged in the early stages of the design process. However, one may have some ideas about the relative difference in cost price. E.g. one concept seems to be more expensive than the other one, because of a larger number of parts or a more complex construction. In choosing the (more general reformulated criteria) it seems logical not to have more than eight to ten criteria.

References and Further Reading

Pugh, S. (1981) 'Concept selection: a method that works' In: Hubka, V. (ed.) Review of Design Methodology. Proceedings International Conference on Engineering Design, March 1981, Rome. Zürich: Heurista, 1981, pp.497 – 506.

Roozenburg, N.F.M. and Eekels, J. (1995) Product Design: Fundamentals and Methods, Utrecht: Lemma.

Roozenburg, N. and Eekels, J. (1998, 2nd ed.) Product Ontwerpen: Structuur en Methoden, Utrecht: Lemma.

Weighted Objectives Method

What Is the Weighted Objectives Method?

The Weighted Objectives Method (see figure 2.62) is an evaluation method for comparing design concepts based on an overall value per design concept. The biggest disadvantage of using the Datum Method or the Harris Profile is that the scores per criterion cannot be aggregated into an overall score of the design alternative. This makes a direct comparison of the design alternatives difficult. The Weighted Objectives Method does exactly this: it allows the scores of all criteria to be summed up into an overall value per design alternative.

The Weighted Objective Method assigns scores to the degree to which a design alternative satisfies a criterion. However, the criteria that are used to evaluate the design alternatives might differ in their importance. For example, the 'cost price' can be of less importance than 'appealing aesthetics'.

The Weighted Objectives Method involves assigning weights to the different criteria. This allows the decision-maker to take into account the difference in importance between criteria.

	weight	concept 1	concept 2	concept 3
controllable on velocity and direction	2	5	2	2
safe	3	6	3	3
gain enough speed	4	3	4	4
basic construction simple	1	7	5	1
well accesible parts	2	8	5	2
distinct	4	4	7	4
stable	3	3	8	3
compact	1	6	3	1
springs	1	8	2	1
price	3	7	5	3
total score		125	130	89

fig. 2.62 Example of Weighted Objectives Mehtod (from student report)

An example of a weighted matrix from student report.

When Can You Use the Weighted Objectives Method?

The Weighted Objectives Method is best used when a decision has to be made between a select number of design alternatives, design concepts or principal solutions. Usually, the Weighted Objectives Method is used when evaluating design concepts, and to make a decision as to which design concept should be developed into a detailed design.

How to Use the Weighted Objectives Method?

Starting Point

A limited number of concepts.

Expected Outcome

A chosen concept.

Possible Procedure

1. Select the criteria according to which the selection will be made. These criteria should be derived from the programme of requirements (note that probably not all requirements are applicable at this stage of the design process).
2. Choose 3 to 5 concepts for selection.
3. Assign weights to the criteria. The criteria should be appointed weights according to their importance for the evaluation. To determine the weight factor of the criteria it is recommended that you compare the criteria in pairs to attribute a weight factor. Rank each of the weights on a scale from 1 to 5 (you can also decide on a total sum of the weights of the criteria, for example 100). Make sure you discuss the tradeoffs between the criteria. Trade-offs will have to be made when weights are assigned to the individual criteria (when you are determining which of the weights are more important).
4. Construct a matrix, with the criteria in rows, and the concepts in columns.
5. Attribute values to how each concept meets a criterion. Rank the scores of the concepts from 1 to 10.
6. Calculate the overall score of each concept by summing up the scores on each criterion (make sure you take into account the weight factor).
7. The concept with the highest score is the preferred concept.

Tips and Concerns

- This method should be carried out intelligibly, while discussing and reviewing both the weights assigned to the criteria and the scores of the concepts according to all the

criteria.

References and Further Reading

Roozenburg, N.F.M. and Eekels, J. (1995) Product Design: Fundamentals and Methods, Utrecht: Lemma.

Roozenburg, N. and Eekels, J. (1998, 2nd ed.) Product Ontwerpen: Structuur en Methoden, Utrecht: Lemma

Instructions for using a Pugh Chart

Read through the guide here and watch the video below for detailed instructions.



One or more interactive elements has been excluded from this version of the text. You can view them online here: <https://uark.pressbooks.pub/mechanicaldesign/?p=119#oembed-1>

DEVELOP PROTOTYPES TO FURTHER DEFINE CONCEPTS

The following is an excerpt from the Delft Design Guide.

Daalhuizen, Jaap. 2018. Delft Design Approach, Delft University of Technology.

Design Drawing

When you enter a design studio you will find out that drawing by hand is an integral part of the decision making process, used in the early stages of design, in brainstorm sessions, in the phase of researching and exploring concepts, and in presentation. Drawing has proved to be a versatile and powerful tool for exploring and for communicating. (see: Sketching, Eissen 2007).

Exploring

Explorative drawing enables the designer to analyze visually and to generate and evaluate ideas throughout the entire product design cycle, and especially in the synthesis phase (see section 1.3 – The Basic Design cycle *in the linked PDF above*). That also includes:

- Analyzing and exploring the perimeters of the problem definition
- Using drawings as a starting point for new ideas, by means of association
- Exploring shapes and their meaning, function and aesthetics
- Analyzing and structuring principle solutions and visualizing structural and formal concepts (see section 1.5 – The Fish Trap Model *in the linked PDF above*).

Hand drawing is also beneficial to the development of the designer's visual perception, his or her imaginative capacities and perceptiveness of form in general.

Communicating

Next to verbal explanation, a designer also uses drawing to interact and communicate with several groups of people, with different levels of understanding of professional jargon:

- Fellow-designers or team members
- Model makers
- Marketing managers
- Clients and contractors
- Public offices.

Effective Drawings

The significance of a drawing depends on the context in which it is made. A drawing serves its purpose when it is efficient. Therefore a certain phase in the design process may require a certain type of drawing. Time is an issue and in many cases, a quick, suggestive sketch is preferable to a more time consuming rendering.

For generating and evaluating ideas, hand drawing is more versatile than CAD rendering and prototyping. A rendering can look very definite and unchangeable, which is not appropriate, for example, when a studio is still conferring with its client about design directions and possibilities. A (brainstorm) sketch can also easily be upgraded into a more presentable drawing, on paper or digitally by using a tablet and e.g. Adobe Photoshop or Corel Painter.



Example of product drawings at different fidelity levels.

Early Phase

In the early phase of the design process, drawing tends to be simple: basic shapes or configurations, (grey) shading and casting shadows (figure 2.37). This kind of drawing incorporates the basic skills and rules of perspective, construction of 3D shapes, shading and constructing cast shadows (figure 2.38). Color is not always used and very often this kind of drawing will suffice for idea sketching or structural concepts (fig. 2.38, and see section 1.6 – The Fish Trap Model).

Preliminary Concept Sketching

When several ideas are combined to develop preliminary concepts, the designer has a general idea about the materials being used, the shape, its function and how it is manufactured. Colour and expression of the materials (e.g. matt or reflective plastic) become more important and drawings become more elaborate. (figure 2.39) Side-view sketching can be a quick and easier way of making variations in shape, colour, details, etc. (figure 2.40).

Mixed Media

With a PC and tablet the designer can easily adjust colour and shading in the (scanned) drawing and add textures or the brand name. Computer sketching also has some advantages. It can speed up the drawing and enhance the designer's eye-hand coordination and muscular movement. A relatively new explorative medium in generating ideas is called Intuitive Sketching (van den Herik and Eissen, 2005). This method uses a simple doodle as a starting point (figure 2.41), as a means to break free from conditioning, to express feeling without hindrance, and to expand your visual language.

By combining or integrating several drawings with other types of images (figure 2.42a and b), layers of information can be presented in a coherent way and a suitable context can be provided: the meaning of the product, user environment, etc.

Material Concept Sketching or Preliminary Design

When concepts become definitive, when you want to explore or explain how different manufactured parts are assembled, or when you are communicating with an engineer, choosing an exploded view is effective (figure 2.43). Side-view drawings for exact dimensions, detail drawings, 'ghost' view or shaded cross-sections can also be very useful in communication. Drawings of user interaction can serve to get feedback from users, prior to the testing of prototypes (figure 2.44).

References and Further Reading

Eissen, J.J., van Kuijk, E. and de Wolf, P. (1984) *Produkt Presentatietechnieken*, Delft: DUP.

Eissen, J.J. and Steur, R. (2007) *Sketching: Drawing Techniques for Product Designers*, BIS Publishers.

van den Herik, Y. and Eissen J.J. (2005) Intuitive sketching: a new and explorative medium in generating ideas, CAID&CD' Delft 2005: applications of digital techniques in industrial design engineering. pp. 708-713. Beijing: International Academic Publishers

<http://www.sketching.nl/> (retrieved May 2009). see also www.designdrawing.io.tudelft.nl

Three-dimensional Models

What Are Three-dimensional Models?

A three-dimensional model is a physical manifestation of a product idea. It is a hand-built physical model that represents a mass-manufactured product. In the design process, three-dimensional models are used to express, visualise and materialise product ideas and concepts. Three-dimensional models are also called prototypes: the word prototype comes from the Latin words *proto*, meaning original, and *typus*, meaning form or model. Thus, a prototype is an original form, a first-of-its-kind model.

Prototypes offer more than drawings. Prototypes are tangible, three-dimensional forms; they can be picked up, turned over and looked at from different points of view as opposed to drawings. With prototypes, tests and measurements can be carried out to verify whether a particular solution or solution principle works. And prototypes are effective tools to communicate product ideas and concepts. Building prototypes is a form of visualising the final product form. It is a technique just like sketching, making final drawings, photography or filming. In that sense, prototypes are tools that serve the design process. More specifically, prototypes serve the form-giving process in designing.

In the practice of design, prototypes are used as important steps in the product development process. Prototypes serve the industry to test product aspects, change constructions and details, and to reach consensus within the company on the final form.

In mass production, prototypes are also used to test functionality and ergonomics. Changes that need to be made after the production preparation are often expensive and time-consuming. The final prototype thus serves for the preparation and planning of production. The first phase in the production process is called the null series: these first products (still a sort of prototypes) are used to test the production process.

Prototypes are used in the generation of ideas and concepts for three reasons:

1. Generating and developing ideas and concepts
2. Communicating ideas and concepts in design teams
3. Testing and verifying ideas, concepts and solution principles.

Prototypes for Generating and Developing Ideas and Concept

Sketch models (see figure 2.45) are kinds of prototypes that are used frequently in the phase of generating ideas and concepts. Simple materials are used, such as paper, cardboard, foam, wood, adhesives, wire and solder. Sketch models are tools that are used to visualize early ideas and to develop those early ideas into better ideas and concepts.

fig. 2.45 Sketch Model

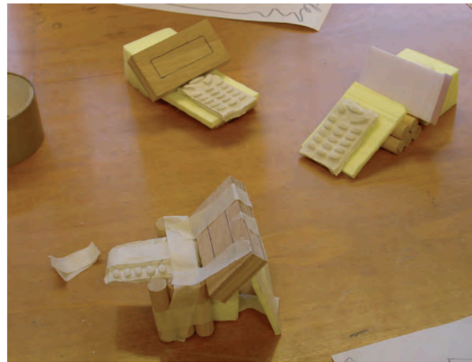

fig. 2.49 Model to test use



fig. 2.46 Proof-of-concept model or FUMO



fig. 2.47 Dummy (mock-up or VISO)



fig. 2.48 Final prototype

3D models of different abstraction levels.

Often you see an iterative process between sketching, making sketch models, drawing, and making a second generation of sketch models.

Proof-of-concept prototypes (see figure 2.46) are used to verify whether certain technical principles actually work. Materials such as technical Lego, Meccano or Fisher Techniek (prototype material) can be used. Proof-of-concept prototypes are simplifications; often details are left out, and only rudimentary forms and working principles are built. Proof-of-concept prototypes are also called FUMO's: Functional Models. Based on the moment in the idea generation phase, the level of detail is determined and the choice of materials. In the beginning of idea generation, prototypes are often built of paper, cardboard and foam. At the end of idea generation, prototypes of the concepts are made of foam, wood and metal.

A dummy (mock-up) (see figure 2.47) is a 1:1 scale model of the product idea. A dummy is a prototype that only has the external characteristics of the product idea, and not the technical working principles. It is often built at the end of the idea generation, to visualise and present final concepts. A dummy is also called a VISO: a Visual Model.

A detailed model is used in the concept generation phase to show particular details of the concept. A detailed model is much like a dummy; both are 1:1 scale models with predominantly external characteristics of high quality. A detailed model can also have some limited functionality.

A final model (see figure 2.48) often concludes the concept generation phase. The final model is a prototype that has a high-quality look, built of wood, metal or plastic, with real buttons and high-quality paint or finishing. The final model might also include some of the technical working principles.

Prototyping to Communicate Ideas and Concept in Design Teams

Prototypes are effective tools for communication purposes. When working in a team, prototypes help in building a shared understanding of the design problem and the solutions (ideas and concepts). Sketch models with increasing levels of detail help the development of product ideas and concepts within the team.

For the communication of ideas to parties outside the design process (for example stakeholders involved), prototypes are also a powerful tool. Often a dummy or a final model is used to present a product idea or product concept. Knowing the audience to whom you are presenting

is important, though, in order to present an appropriate prototype built from the right materials and with the right techniques.

Prototyping to Test and Verify Ideas, Concept and Solution Principles

Prototypes also serve the purpose of testing and verifying ideas, concept or solution principles. (See figure 2.49, also see 'Evaluation of Product Features' in section 2.4).

There are generally three types of tests for which prototypes are used:

1. Testing technical – functional characteristics of a product idea. Often a sketch model is used with some working functionality, or functioning technical principle, based on the goals of the test.
2. Testing form characteristics. Often a detailed model is used for judging user preference.
3. Testing usability characteristics. Often a final, working model is used for testing the intended usability of a product concept.

When Can You Use Three-dimensional Models?

Prototypes can be used throughout the conceptual design process. In the beginning of idea generation, various types of sketch models are used. During idea generation a dummy or detailed models are used, and the concept generation phase is often concluded with a final model.

How to Use Three-dimensional Models?

Starting Point

The starting point of building models can be a (mental) sketch of a product idea (sketch model) or detailed drawings and a building plan (final model).

Expected Outcome

The outcome of building models are threedimensional, tangible models of an idea, concept or solution principle.

Possible Procedure

1. Three-dimensional model building starts with some notion of an idea, concept or solution principle.
2. Based on the purpose of the model, some level of detail has to be determined prior to collecting materials, devising a plan and building the model. Simple sketch models at the beginning of idea generation only require a simple sketch, while final models (final prototypes) require a detailed plan of how to build the model.
3. Collect the appropriate materials, such as paper, cardboard, wood, foam, adhesives, plastics, metals, wire, and paint.
4. Devise a plan for building the model. For a simple sketch model, early idea sketches are often enough. Detailed or final prototypes usually require detailed drawing including dimensions.
5. Build the prototype (see figure 2.45).

Tips and Tricks

- Look for examples of what different sketch models can look like. Sketch models as simple as paper and glue are often very helpful in the beginning of the idea generation. Try this yourself!
- Many examples can be found of final models, or detailed models. •
- Use the expertise of the people working in model workshops.
- Select your tools for model making well

References and Further Reading

Roozenburg, N.F.M. and Eekels, J. (1995) Product Design: Fundamentals and Methods, Utrecht: Lemma.

Roozenburg, N. and Eekels, J. (1998, 2nd ed.) Product Ontwerpen: Structuur en Methoden, Utrecht: Lemma.

Interested in Getting Better at Sketching?

Check out this and the following videos in the series. Like everything else, it take lots of repeated pactice!



One or more interactive elements has been excluded from this version of the text. You can view them online here: <https://uark.pressbooks.pub/mechanicaldesign/?p=117#oembed-1>

WRAP UP - CONCEPTUAL DESIGN AND TOOLS

Summary

This chapter explored creative ways to explore the design space and develop innovative concept solutions. Techniques such as brainstorming and mind mapping can help you to generate and capture ideas. More specifically, a morphological matrix can be used to develop sub-solutions for all of the sub-functions of your product. Through synthesis, you can combine these sub-solutions to form a large and diverse set of concept solutions. Finally, after these ideation activities, your team can use decision-support tools such as the Pugh chart to evaluate, refine, and select the most promising concept to move forward to detailed design.

Questions



An interactive H5P element has been excluded from this version of the text. You can view it online here:

<https://uark.pressbooks.pub/mechanicaldesign/?p=303#h5p-6>

PART VI

SYSTEMATIC AND ITERATIVE PROCESS OF EMBODIMENT DESIGN

Learning Objectives

In this chapter we will look at the detailed design from a high-level and focus on different aspect of detailed design in later chapters. By the end of this chapter students will be able to:

- Describe and apply a systematic process to move from constraints to architecture to connection between assemblies and finally to component specification.
- Describe and utilize an iterative approach for concept refinement.

The detailed design stage, also known as the embodiment stage, is where a concept is refined through engineering analysis. This stage involves transforming the abstract idea into a concrete specification that can be implemented and tested. The detailed design stage can include activities such as selecting materials, defining dimensions, performing simulations, verifying functionality, and optimizing performance. The detailed design stage is crucial for ensuring the feasibility, reliability, and quality of the final product.

In this stage, product designers have to make many decisions that involve trade-offs between different aspects of the product, such as performance, sustainability, cost of manufacturing and assembly, aesthetics, ergonomics, usability, and so on.

For example, a product designer may have to choose between different materials for a product component, such as plastic, metal, wood, or composite. Each material has its own advantages and disadvantages in terms of strength, durability, weight, environmental impact, recyclability, availability, and cost. The product designer has to evaluate these factors and select the most suitable material for the product's function, target market, and design specifications.

Another example of a trade-off decision in the embodiment stage is the level of complexity and integration

of the product components. A product designer may have to decide whether to use more or fewer parts, whether to combine or separate functions, whether to use standard or custom parts, and so on. These decisions affect the performance, reliability, maintainability, modularity, adaptability, and assembly of the product. The product designer has to balance these aspects and optimize the product's structure and configuration.

The embodiment stage of product design is a complex and iterative process that requires creativity, analysis, evaluation, and communication skills from the product designer. The product designer has to consider many factors and constraints and make trade-off decisions that satisfy the customer's needs and expectations, as well as the technical and economic feasibility of the product.

OVERVIEW OF THE DESIGN EMBODIMENT PROCESS

The first step is to define the system level constraints and requirements, such as the functionality, performance, reliability, safety, cost, and environmental impact of the product. These constraints and requirements guide the selection of the best design alternatives and evaluation criteria. The system level constraints and requirements also help to identify the main subsystems and interfaces that make up the product.

The second step is to determine the configuration or architecture of the system, which is the arrangement and integration of the subsystems and interfaces. The configuration or architecture of the system should satisfy the system level constraints and requirements, as well as optimize the trade-offs between competing objectives, such as weight, size, complexity, and manufacturability. The configuration or architecture of the system can be represented by various tools, such as block diagrams, functional flow diagrams, or morphological charts.

The third step is to define the interfaces and connections between components and sub systems. This specifically helps determine the ideal operating window for a component performance and ensures that physical and functional limits are not exceeded.

The fourth step is to specify the components or subsystems that constitute the system, which are the individual parts or assemblies that perform specific functions within the product. The components should meet the specifications and requirements derived from the system level and the configuration or architecture of the system. The components or subsystems should also be compatible with each other and with the interfaces and connections that link them together.

Finally, designers need to iterate through the decisions made based on constraints, architecture, interfaces, and components to solve conflicts and optimize a design with respect to cost, performance, and quality. This may involve revisiting the initial requirements, specifications, and assumptions, as well as testing and evaluating the design against the desired criteria.

CONSTRAINTS

Constraints at the system level lead to constraints at the assembly and component level. Therefore, it is important to define the envelope of operation, which is the range of conditions and parameters that the system must operate within, to reduce the design space to feasible solutions. Several important constraints are power, spatial, and sequence of operations.

Power constraints refer to the amount and type of energy that the system requires to function properly. For example, a laptop computer has a power constraint at the system level, which is the battery capacity and voltage. This constraint affects the assembly level, such as the motherboard and the processor, which have to consume less power and generate less heat. The component level, such as the transistors and resistors, also have to meet the power constraint by having low resistance and high efficiency.

Force, strength, or stress constraints refer to the capacity of the material to resist deformation or mechanical failure under load. For many mechanical systems these are derived from the power constraints. The weight capacity for a product is an example of a system level constraint that will affect the geometry and material choices for the components within that system.

Spatial constraints refer to the physical dimensions and shape of the system and its parts. For example, a bicycle has a spatial constraint at the system level, which is the overall size and location of assemblies. These constraints affect the assembly and component level, such as the frame, wheels, and gearing.

Sequence of operations constraints refer to the order and timing of events that occur within the system. For example, a coffee machine has a sequence of operations constraint at the system level, which is the process of brewing coffee. This constraint affects the assembly level, such as the water tank and the filter, which have to work in sync. The component level, such as the valves and the sensors, also have to meet the sequence of operations constraint by having accurate control and feedback.

CONFIGURATION AND ARCHITECTURE

Define the system architecture refers to how the assemblies and components are arranged and connected. The system architecture decision should take into account the constraints that apply to the product, such as size, weight, functionality, safety, cost, etc.

A common mistake that beginner designers make is to create designs that have too many separate parts. This can lead to problems such as increased complexity, difficulty in manufacturing and assembly, higher cost, lower reliability, and more waste. A better approach is to try to design parts that are complex but elegant, meaning that they have multiple functions or features integrated into one piece. This can reduce the number of parts, simplify the assembly process, lower the cost, improve the performance, and enhance the aesthetics of the product.

For example, consider a bicycle frame. A novice designer might design a frame that consists of many tubes and joints that are welded or bolted together. This would result in a heavy, bulky, and weak frame that is hard to produce and maintain. A more experienced designer would design a frame that is made of fewer tubes that are shaped and curved to fit together smoothly and securely. This would result in a lighter, sleeker, and stronger frame that is easier to produce and maintain.

Modules

Modules are self-contained units that perform specific functions or provide a specific feature. Modules can be designed independently, tested separately, and integrated easily into larger systems. Modules can also be modified, replaced, or upgraded without affecting the rest of the system. This reduces the complexity, cost, and time of product development and maintenance.

An example of a modular product design, smartphone consists of several modules, such as the screen, camera, battery, processor, etc. These modules can be swapped or upgraded to improve the performance or functionality of the phone. This can also enable the development of product families, where similar modules are used to generate similar products with different features.

Here are some of the good reasons for chunking components into modules:

1. Enabling standardization: Standard modules can help reduce the number of different parts and interfaces in a product, which simplifies the design, manufacturing, and maintenance processes. For example, a modular power supply can be used for different electronic devices with different voltage and current requirements.
2. Precise geometric location requirements: Modules can help achieve precise alignment and positioning of components that are critical for the function or appearance of the product. Specifically, when one or more

components needs to be precisely located with respect to another, it often is helpful to combine those parts into a single module.

3. Sharing of functions: Modules can help avoid duplication of components or assemblies that perform similar or multiple functions in a product. For example, a mechanism for moving product on a manufacturing line can be constructed as a single module to more precisely control movement and clamping.

4. When vendors are limited to specific capabilities or expertise: Modules can help outsource some parts of the product design or manufacturing to external vendors who have specialized skills or equipment. For example, a modular battery pack can be purchased from a vendor who has expertise in battery technology and safety. Power conversion modules like motors will have a different underlying expertise for development.

5. Similarity of the manufacturing or assembly process: Modules can help streamline the production process by grouping components that have similar fabrication or assembly methods. For example, a vehicle chassis can be made from the same material and process as other structural components of a car.

6. Localization of future changes: Modules can help reduce the impact of design changes or updates on the rest of the product by isolating the affected components in one module. For example, a display screen can be upgraded to a higher resolution or size without affecting the other parts of a device.

7. Enabling variety or customization: Modules can help increase the diversity and flexibility of the product by allowing different combinations or configurations of components to suit different user needs or preferences. For example, a furniture system can be assembled into different shapes and sizes according to the available space and style.

CONNECTIONS AND INTERFACES

Interfaces control the flow of energy, material, and signal or information between components. They should be designed to consider equilibrium and equivalency of flows. For example, the interface between a power system and power using component should be specified to a consistent power level (voltage and current). Additionally, the same type of flow must be consistent. It may seem obvious that if a liquid exits one component it should not be considered a thermal energy by the next component. However, heat exchangers do this exact behavior. The concept of primary and secondary flow can be useful to ensure that designers are considering all aspects. Using this example, the interfaces must consider both a flow rate, pressure, and thermal energy carried by that flow. Failure to consider all properties of the flow can lead to unexpected failure.

Interfaces and the connections between components is the course of much of the complexity and required design hours for a product. There are a few principles that can help reduce the time and risk of needed redesign.

- *Work from the outside in.* It is generally best to begin with external interfaces and work your way into the details of the product. Consider the input and output flows of material, energy and information. Things like the power to a product as well as any human interaction interfaces. Next, it is helpful to consider primary flows or primary functions. These are the flows or functions that you as the designer deem are most critical.
- *Be prepared for the generation of new functions and requirements.* When specifying an interface, it can often lead to identifying new functions and requirements. For example, excess heat or vibration from two mating parts needs to be controlled – a new function introduced by the interface.
- *Leverage interface design to support functional independence of components and assemblies.* By keeping assemblies functionally independent, designers reduce the risk of change propagation. That is, if a flow must travel between to component or assemblies to perform a single function, then consider redesigning the component or assembly.

Consider how the complexity of a product grows with the interactions between components. We can describe these interactions using a design structure matrix. This is a special matrix with all of the components listed in both the columns and rows. This is also called an adjacency matrix in domain of math known as graph theory. The most complexity is when every component is connected with every other component. Imagine a densely interconnect graph or network. Ideally, we want to minimize the number of connections and implied interfaces. One approach to doing this comes from a design theory known as Axiomatic Design.

Axiomatic Design

Axiomatic Design is a systems design methodology that uses matrix methods to systematically analyze the transformation of customer needs into functional requirements, design parameters, and process variables. It is based on two design principles or axioms that govern the analysis and decision-making process in developing high quality product or system designs. The two axioms are:

Axiom 1: The Independence Axiom. Maintain the independence of the functional requirements (FRs).

Axiom 2: The Information Axiom. – Minimize the information content of the design.

The Independence Axiom states that the FRs should be satisfied independently of each other by the corresponding design parameters (DPs). This ensures that changing one DP does not affect multiple FRs, which would cause coupling or interference among them. The Information Axiom states that the design should have the minimum probability of not satisfying the FRs, which is measured by the information content of the design. This ensures that the design is robust and reliable under various conditions.



One or more interactive elements has been excluded from this version of the text. You can view them online here: <https://uark.pressbooks.pub/mechanicaldesign/?p=135#oembed-1>

Types of Physical Interfaces

A physical interface is the way that two or more components are connected or attached to each other. There are different types of physical interfaces depending on the function and design of the components.

- Fixed and non-adjustable interfaces are used when the components need to be rigidly attached and aligned, and there is no need for adjustment or movement. For example, a bolt and nut can create a fixed and non-adjustable interface between two metal plates.

- Adjustable interfaces are used when the components need to have some degree of flexibility or variability in their position or orientation. For example, a screw and a slot can create an adjustable interface between a bracket and a wall, allowing the bracket to slide along the slot.

- Locator interfaces are used when the components need to be positioned or aligned in a specific way, but not necessarily attached. For example, a pin and a hole can create a locator interface between a lid and a box, ensuring that the lid fits snugly on the box.

- Hinged or pivoting interfaces are used when the components need to have some degree of rotation or

angular movement. For example, a hinge can create a hinged or pivoting interface between a door and a frame, allowing the door to swing open and close.

The Principle of Exact Constraints

The principle of exact constraints states that a component should be designed with the minimum number of constraints necessary to ensure its proper functioning. This means that the product should have no redundant or overconstrained elements that could cause stress, deformation, or failure. For example, a table with four legs is exactly constrained, as each leg supports one corner of the table. A table with five legs is overconstrained, as one leg is redundant and could create instability or unevenness. A table with three legs is underconstrained, as it could wobble or tip over.



One or more interactive elements has been excluded from this version of the text. You can view them online here: <https://uark.pressbooks.pub/mechanicaldesign/?p=135#oembed-2>

DEFINE COMPONENTS

After defining the interfaces between components, the next step is to define the components themselves. This involves the following major steps:

- Define the major function of each component. This is the primary purpose or role of the component in the product, such as providing support, transmitting power, or controlling motion.
- Determine if your company will make or buy the component. This depends on factors such as availability, quality, cost, and lead time of existing components in the market, as well as your company's core competencies and strategic goals.
- If buying, source the component based on its properties and cost. You should consider the technical specifications, performance, reliability, and compatibility of the component with your product and other components. You should also compare the prices and delivery times of different suppliers.
- If making parts in-house, perform engineering analysis to design the component. You should use the interfaces with other components to help define the shape of the part that can achieve its major function. You should also perform stress and other failure analysis to determine the optimal geometry, material, and manufacturing method for the component. You should consider the trade-offs between performance, durability, weight, and cost of the component.

The Make/Buy Decision

One of the key challenges in this stage is choosing between custom-made and commercial off-the-shelf (COTS) components. Custom components can offer more flexibility, functionality, and differentiation, but they also entail higher costs, risks, and lead times. Off-the-shelf components can reduce complexity, expenses, and time to market, but they may limit the product's performance, features, and uniqueness.

Mechanical springs are a great example. Spring manufacturers can provide custom springs for nearly any application. They also produce a very large catalog of standard springs. Consider what factors justify the time needed to design, test, and validate a custom spring versus choosing a standard spring that is close, but not exactly the performance level desired.

To make an informed decision, product designers should follow some best practices:

- Define the product's value proposition and target market. What are the main benefits and problems that the product solves for the customers? Who are the ideal customers and what are their needs, preferences, and expectations? How does the product compare to the existing alternatives and competitors? If your main proposition is that the current products on the market cannot achieve a level of performance, this is an indication that a more unique approach is needed and may justify pursuing custom part manufacturing.

- Identify the critical components and functions of the product. What are the essential parts and features that enable the product to deliver its value proposition? What are the technical specifications and quality standards that these components and functions must meet? How do they interact with each other and with the external environment?

- Evaluate the feasibility and availability of custom and standard components. What are the technical, financial, and operational requirements and constraints for developing or sourcing custom or standard components? How easy or difficult is it to find, test, integrate, and maintain them? How reliable and scalable are they? How do they affect the product’s cost structure and profitability?

- Assess the trade-offs and risks of custom and standard components. What are the advantages and disadvantages of each option in terms of performance, functionality, differentiation, cost, time, risk, and customer satisfaction? How do they align with the product’s value proposition and target market? What are the potential pitfalls and challenges that could arise from choosing one option over the other?

- Make a data-driven decision based on multiple criteria and scenarios. Use a decision matrix or a similar tool to compare and rank custom and standard components based on multiple factors and weights. Consider different scenarios and assumptions that could affect the outcome of the decision. Seek feedback from stakeholders, experts, and customers to validate and refine the decision.

Many products use a combination of both custom and off the shelf components. In the following chapters, we will discuss the approach to specifying common mechanical components (off the shelf or minimal customization). Unfortunately, for designing novel custom parts, the guidelines are less clear. Instead, designers use best practices like “universal design” principles and best practices for “design for manufacturing and assembly”.

ITERATE AND REFINE

The process of moving from constraints to architecture to interfaces and finally components is not linear but recursive. That is, we start at the system level and define major assemblies or modules. Then work through the same process to work towards individual component specification within an assembly. Unfortunately, decisions made in one assembly often affect the constraints or interfaces in another. The same is true even within an assembly where component specification affects other components. This leads to one of the major efforts of engineering design: Patching, Fixing and Satisficing.

Patching – Fixing – Satisficing

It is unlikely that a designer can develop a custom component or specifying a commercial off the shelf component in a single sitting. Rather, the parts and specification become more refined as the concept becomes less abstract.

Finding the gaps between component and assembly interfaces leads to refinements called patching. Patching is also used a means to implement needed secondary functionality. For example, a component may need attachments to a housing or other component. Defining the location, type and size of those attachment points is a patching process.

A major pain point in engineering design is discovering conflicts in the design specifications or requirements. These are often unexcepted and cost time and resources to solve. For example, when a material choice for the strength of a component leads to unacceptable total weight or stiffness. Resolving these conflicts is precisely what makes elegant and novel products. Sometimes there are ways to solve a conflict through innovative thinking. One powerful tool for this is call the “Theory of Inventive Problem Solving” or TRIZ.

Here is one implementation of TRIZ that you can try to solve a design conflict:

TRIZ 40

Finally, we aim to work through the detailed design stage with a goal of satisfying stakeholder needs. A well refined product is well suited for detailed optimization. However, in the development process, the designer’s goal should be to find satisfactory solutions. That is, when all stakeholder’s needs are satisfied.

WRAP UP - DETAILED DESIGN

Summary and Key Concepts

Embodiment design is an iterative process that involves balancing constraints and trade-offs. It can feel difficult to know where to start when you have a concept but not sure how to get that refined enough to develop functional prototypes and plan the manufacturing process. One of the most productive approaches is to work from constraints to product architecture to interfaces and finally component or subsystem specification. This is both an iterative process and requires addressing conflicts and analysis to find ideal solutions which satisfy stakeholder needs.

Questions



An interactive H5P element has been excluded from this version of the text. You can view it online here:

<https://uark.pressbooks.pub/mechanicaldesign/?p=305#h5p-7>

PART VII

SPECIFICATION OF STANDARD MECHANICAL COMPONENTS

Learning Objectives

In this part we will look at some best practices and guidelines for specifying and buying common mechanical components from suppliers. By the end of this section, readers will be able to:

- Understand and describe the process for selecting off the shelf components from suppliers
- Utilize common best practices for identifying the ideal range of values for specifying a component
- Utilize supplier tools to identify parts based on the specification

It is very common in most machine and mechanical design applications that at least some of the components that form the product will be off the shelf components from a supplier. Economies of scale dictate that it is far more economical to purchase standard parts or have customized parts made by a supplier that already has the required manufacturing equipment, expertise, and supply chains established. These types of parts are known as **COTS** or commercial off the shelf components.

COTS of common mechanical products such as gears, bearings, pins, springs, etc., are widely available from various manufacturers and suppliers, and can offer advantages such as lower cost, shorter lead time, higher reliability, and easier maintenance. However, finding and specifying the right off-the-shelf components can be a complex and time-consuming process that involves multiple steps and considerations.

Some of the steps involved in the process of specifying and finding off-the-shelf components are:

- Define the design criteria and constraints for the component, such as size, load, speed, temperature, environment, service life, etc.
- Identify the possible types and categories of components that can meet the design criteria and constraints, such as spur gears, ball bearings, cotter pins, helical springs, etc.
- Search for available products from different manufacturers and suppliers that match the type and

category of the component, using online catalogs, databases, websites, etc.

- Compare and evaluate the products based on their specifications, features, ratings, costs, availability, etc., and select the most suitable ones for further analysis.
- Perform detailed calculations and simulations to verify that the selected products can satisfy the design criteria and constraints under the expected operating conditions.
- Check for compatibility and interference issues with other components and parts of the system and make any necessary adjustments or modifications.
- Document the component selection process and results and prepare a bill of materials (BOM) that lists the part numbers, quantities, descriptions, prices, etc., of the selected components.

GENERALIZED PROCESS FOR STANDARD SPECIFICATIONS

Primary and Secondary Functions

The first step in specification of a COT component is the identification of the type of component. This will depend on the primary function of the component. However, there are many components that can implement similar high-level functions. The decision often comes down to secondary functionality. For example, the primary function of “transmit power” can be accomplished with many different types of components such as belts, various types of gearing etc. However, if secondary functionality like changing the direction of the power is also needed, then components like bevel gears make more sense than belts and pulley systems.

The table below details the primary functional categories for many common mechanical components. Most of these components are COTs but some will require significant work with suppliers to design. The following pages will detail the specification process for some of these components but not all. We will focus on the components that can be readily purchased without needing to work closely with suppliers to customize the component.

Table of the High-Level Common Mechanical Component Types and their Primary Functionality

Locate	Energy Storage	Energy Conversion	Energy Transmission
Threaded Fasteners <ul style="list-style-type: none"> • Bolts • Nuts and locking nuts • Grub screws • Studs • Screws • Expanding bolts 	Springs <ul style="list-style-type: none"> • Compression • Extension • Torsion • Helical • Leaf • Flat • Belleville • Rubber • Spiral • Garter • Torsion bar • Wire form 	Turbo Machinery <ul style="list-style-type: none"> • Gas turbine • Rotodynamic pumps and compressors • Fans • Propellers • Turbines 	Gearing <ul style="list-style-type: none"> • Spur • Helical • Herringbone • Bevel • Miter • Worm • Conformal
Cylindrical <ul style="list-style-type: none"> • Washers, spacers • Retaining rings • Grooves • Tolerance rings • Snap Rings • Circlips 	Thermal/fluid <ul style="list-style-type: none"> • Fluid accumulator • Gas spring • Reservoir • Pressure vessel 	Chemical <ul style="list-style-type: none"> • Rotary • Reciprocating • Fuel cells • Rockets 	Other Rotary <ul style="list-style-type: none"> • Cranks • Cams • Ball screws • Power screws
Pins <ul style="list-style-type: none"> • Cylindrical • Taper • Spring 	Chemical <ul style="list-style-type: none"> • Battery 	Thermal <ul style="list-style-type: none"> • Boilers • Heat exchangers 	Belts and Chains <ul style="list-style-type: none"> • Flat belt • Vee belt • Wedge belt • Round belt • Synchronous belt • Roller chain • Leaf chain • Conveyor chain • Silent

<p>Non-Threaded Fastening</p> <ul style="list-style-type: none"> • Rivets • Nails • Adhesives • Welds 	<p>Mechanical</p> <ul style="list-style-type: none"> • Fly Wheel • Solid mass 	<p>Electrical</p> <ul style="list-style-type: none"> • Motors • Solenoids • Alternators and generators 	<p>Structures</p> <ul style="list-style-type: none"> • Linkages • Pipes and hoses
<p>Keys and Keyways</p> <ul style="list-style-type: none"> • Flat • Round • Profiled • Gib head • Woodruff 		<p>Mechanical</p> <ul style="list-style-type: none"> • Dampers and shock absorbers • Pumps • Pneumatic and hydraulic actuators • Brakes 	
<p>Shape</p> <ul style="list-style-type: none"> • Shoulders • Grooves • Fits 			

Motion Support	Stationary Support	Sense	Switch or Control	Seals
<p>Rolling Element Bearings</p> <ul style="list-style-type: none"> • Deep groove ball • Angular contact ball • Cylindrical roller • Needle roller • Tapered roller • Self aligning • Thrust • Recirculating ball 	<p>Housings</p> <ul style="list-style-type: none"> • Frame • Casings • Enclosures 	<p>Fundamental Properties</p> <ul style="list-style-type: none"> • Motion • Dimension • Mass • Force • Torque • Power • Strain • Stress • Sound • Humidity 	<p>Clutches</p> <ul style="list-style-type: none"> • Square jaw • Multiple serration • Sprag • Roller • Drum • Disk • Magnetic • Synchromesh 	<p>Dynamic Seals</p> <ul style="list-style-type: none"> • Mechanical face • Lip ring • Bush • Labyrinth • Brush • Ferrofluidic • Rim seals • O Rings • Packings • Piston rings
<p>Sliding Bearings</p> <ul style="list-style-type: none"> • Plain rubbing • Hydrodynamic • Hydrostatic 	<p>Structures</p> <ul style="list-style-type: none"> • Grips • Guides • Clamps • Jigs • Hooks • Handles • Levers 	<p>Pressure</p> <ul style="list-style-type: none"> • Pitot tubes • Static tapping • Manometers • Piezoelectric 	<p>Mechanical</p> <ul style="list-style-type: none"> • Valves • Levers • Ratchet Pawl • Geneva and other index mechanisms • Triggers • Ballistic strips • Latches 	<p>Static Seals</p> <ul style="list-style-type: none"> • Gaskets • O Rings • Sealants

Wheels, Rollers, Brushes, Pulleys		Temperature and Heat Flux <ul style="list-style-type: none">• Thermocouples• Resistance• Thermometers• Pyrometers• Thermopile• Gardon gauge		
Hinges, Pivots, Joints		Mass Flow <ul style="list-style-type: none">• Laser Doppler• Hot wire• Ultra sonic		

FASTENERS

Introductory Video



One or more interactive elements has been excluded from this version of the text. You can view them online here: <https://uark.pressbooks.pub/mechanicaldesign/?p=551#oembed-1>

Mechanical Fasteners

Mechanical fasteners are devices that use force and deflection to implement locating functions, which means they align and secure the parts of a mechanical system. Mechanical fasteners can be classified into two categories: integral fasteners and discrete fasteners. **Integral fasteners** are formed as part of the components they join, such as tabs, slots, and snap-fits. **Discrete fasteners** are separate pieces that are added to the components, such as threaded fasteners, rivets, and pins.

Threaded fasteners are discrete fasteners that achieve locating by joining two parts together with a helical ridge called a thread. Threaded fasteners enable assembly and disassembly of the parts without damaging them. A common type of threaded fastener is a bolt, which is a cylindrical rod with a head at one end and a thread at the other end. Bolts are used with nuts, which are also threaded devices that fit onto the bolts and tighten them. Bolts and nuts have different grades, which indicate their strength and resistance to various loads and environments. The grades are defined by standards organizations such as the Society of Automotive Engineers (SAE), the Society for Testing and Materials (ASTM), and the International Organization for Standardization (ISO). A great comparison of Grades and their specification can be found here. Some examples of bolt types are round head bolts, which have a dome-shaped head, and studs, which have threads on both ends. Some examples of nut types are square nuts, which have four flat sides, and hex nuts, which have six flat sides. Nuts can also be single-threaded or double-threaded, depending on whether they have one or two threads per inch.

Another type of threaded fastener is a screw, which is similar to a bolt but has a pointed tip and is usually driven into a pre-drilled hole in the component. Screws can also be used with nuts or washers to increase their clamping force or prevent loosening. Screws have various types, depending on their function and design. Some examples are machine screws are: cap screws, which have a cylindrical head with a hexagonal or socket shape; set screws, which have no head and are used to secure a shaft or collar; Sems screws, which have a washer attached

to the head; and tapping screws, which create their own threads in the component as they are driven in. Screws also have various heads and tip end conditions, depending on how they are driven and what kind of hole they fit into. Some examples of screw heads are slotted, Phillips, hexagonal, and Torx. Some examples of tip end conditions are blunt, pointed, self-drilling, and self-tapping.

Terminology

The **pitch** of a thread is the distance between two adjacent threads measured along the axis of the fastener. The **lead** of a thread is the distance that the fastener advances along its axis in one turn. The diameter of a thread is the distance between the crests or roots of two opposite threads measured perpendicular to the axis of the fastener. For example, a 1/4-20 UNC bolt has a nominal diameter of 1/4 inch, a pitch of 1/20 inch, and a lead of 1/20 inch. UNC stands for Unified National Coarse, which is one of the standards for imperial units of measurement. Another standard is UNF, which stands for Unified National Fine, which has smaller pitches than UNC. For metric units of measurement, there are different standards such as ISO metric screw threads, which use millimeters as the unit of length. For example, an M6x1 bolt has a nominal diameter of 6 mm, a pitch of 1 mm, and a lead of 1 mm.

Rivets

A rivet is another type of discrete fastener that consists of a cylindrical shaft with a head at one end and a tail at the other end. Rivets are used to join two or more components together by inserting them through holes in the components and deforming the tail to form another head on the opposite side. Rivets can be made of various materials such as steel, aluminum, copper, or plastic. Rivets have some advantages over threaded fasteners such as being cheaper, lighter, more resistant to vibration and corrosion, and more aesthetically pleasing. However, rivets also have some limitations such as being permanent (cannot be disassembled without damaging them), requiring access to both sides of the components (cannot be used in blind holes), requiring special tools for installation and removal (such as hammers or rivet guns), and having lower strength than some threaded fasteners.

PINS AND JOINTS

One of the common types of joints used in machine design is the pin joint, which is a type of fastener that connects two or more parts by passing a cylindrical or tapered pin through holes in the parts. These are often the physical component that makes a revolute joint in a planar mechanism. The pin can be fixed or removable, depending on the application and the design requirements. Some of the advantages of pin joints are that they are simple, cheap, easy to assemble and disassemble, and can accommodate some misalignment and relative motion between the parts. Some of the design challenges for pin components include creating stress concentrations in the parts, requiring accurate hole alignment, and avoiding wear and corrosion.

When designing pin joints, some of the factors that need to be considered are the size, shape, material, and location of the pins, as well as the loading conditions and the service environment of the joint. The pins should be strong enough to resist shear and bending stresses, both from static load and fatigue loading (cycles of load). The pins should also have a suitable fit with the holes to prevent excessive clearance or interference, which can affect the performance and durability of the joint. The pins should be made of materials that are compatible with the parts they connect, and that have good resistance to wear and corrosion.

To specify a pin component from a supplier, some of the design parameters that need to be provided are:

- The type of pin (cylindrical, taper, or spring)
- The nominal diameter of the pin
- The length of the pin
- The tolerance and fit of the pin
- The material and surface finish of the pin
- The quantity and delivery time of the pin

Some of the common types of pins used in machine design are cylindrical pins, taper pins, and spring pins. Cylindrical pins have a constant diameter and are usually driven into reamed holes. They can be solid or hollow, depending on the weight and stiffness requirements. Taper pins have a slightly conical shape and are driven into tapered holes. They have a self-locking feature that prevents them from loosening due to vibration or thermal expansion. Spring pins are hollow cylindrical pins that have a slit along their length. They are inserted into slightly smaller holes and exert a radial force on the walls of the holes. They have a flexible and resilient nature that allows them to accommodate variations in hole size and alignment.

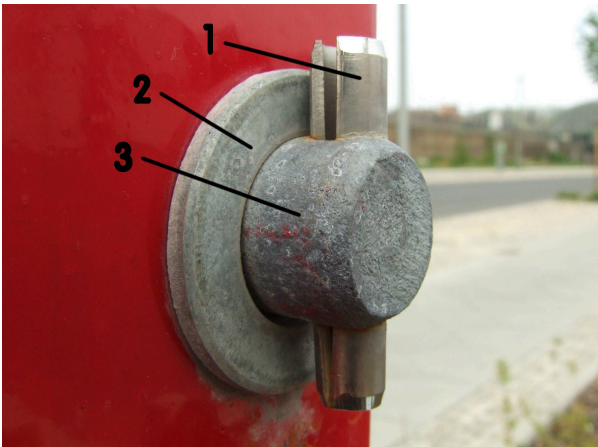

Spring Pin uses the elastic property of the pin material to hold the shaft in place.

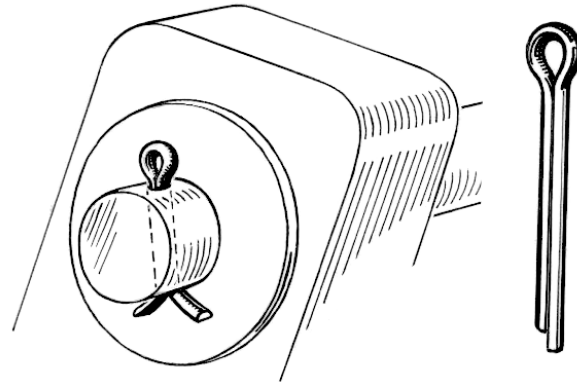

Cotter pins (also called split pin) are used for accurately locating and securing components together.

Some of the common applications of pin joints are cantilever joints, straddle mount joints, and pin and block joints. Cantilever joints are used to connect two parts that are perpendicular to each other, such as a lever and a shaft. The pin is inserted through one part and projects beyond it to support the other part. Straddle mount joints are used to connect two parts that are parallel to each other, such as two shafts or two plates. The pin is inserted through both parts and is supported by bearings or bushings at both ends. Pin and block joints are used to connect two parts that have relative sliding motion along a straight line, such as a piston rod and a crosshead. The pin is inserted through one part and slides in a slot or groove in the other part.

Various types of pins can be purchased from fastener suppliers and general suppliers. If purchasing many pins for a mass manufacturing context, it usually is more cost effective to order directly from a fastener supplier. For small lots, a general part supplier such as McMaster-Carr.

Look at the online catalog for McMaster-Carr for pins here:

[pins | McMaster-Carr](#)

For an example of a fastener supplier catalog, see Spirol products here:

[Innovative Fastening Products | SPIROL.](#)

BEARINGS

Types of Bearings

Mechanical bearings are devices that reduce friction and wear between moving parts by providing a smooth contact surface. Bearings can be classified into two main types: journal bearings and rolling element bearings.

Journal bearings are bearings that support a rotating shaft by allowing it to slide along a lubricated surface. The lubricant, usually oil or grease, forms a thin film that separates the shaft and the bearing, preventing metal-to-metal contact. Journal bearings can be further divided into plain bearings, which have a simple cylindrical shape, and hydrodynamic bearings, which have a curved shape that creates a pressure wedge of lubricant.

Rolling element bearings are bearings that use balls, rollers, or needles to support a rotating shaft. The rolling elements reduce friction by rolling instead of sliding along the contact surface. Rolling element bearings can be further divided into ball bearings, which use spherical balls, and roller bearings, which use cylindrical or tapered rollers. Ball bearings can handle both radial and axial loads, while roller bearings can handle higher radial loads but lower axial loads.

Watch the following CAE video to understand the type of rolling element bearings and their uses:



One or more interactive elements has been excluded from this version of the text. You can view them online here: <https://uark.pressbooks.pub/mechanicaldesign/?p=157#oembed-1>

Questions:

Can you answer the following questions after watching the video:

1. What are the main parts of rolling element bearing?
2. What is the advantage of a roller bearing versus a ball bearing?
3. When selecting a bearing, what factors would influence you to select a roller versus a ball bearing?
4. What is the difference between axial loads and radial loads, what type of bearings are used depending on the load levels?

Bearing Selection

Bearing manufacturers provide useful tools on their website to help identify a bearing. In order to use these tools, you will first need to identify the loads that the bearings will need to support using static force analysis, the speed at which the bearing or shaft will be rotating, and the anticipated service life and desired reliability for the bearing. These parameters will help you determine the size, type, and configuration of the bearing that best suits your application.

The dynamic and static load ratings for bearings are important parameters that indicate the load-carrying capacity and durability of the bearings. The dynamic load rating is the maximum load that a bearing can support under a given speed and operating condition, while the static load rating is the maximum load that a bearing can withstand without permanent deformation. The dynamic and static load ratings are usually expressed in newtons (N) or kilonewtons (kN), and they depend on factors such as the material, geometry, design, lubrication, and cleanliness of the bearings. The dynamic and static load ratings are used to calculate the fatigue life and safety factor of the bearings, respectively.

Try it yourself!

Assume you have found the reactions forces (the radial force) that a bearing needs to support from a static analysis. Use that value to select a rolling element bearing using SKF's selection tool and see how life, reliability and many other factors are calculated based on your loading situation.

Find the SKF bearing selection online tool here:

<https://www.skfbearingselect.com/>

MECHANICAL SPRINGS

As Many Different Types of Springs as any Designer Could Want!

Mechanical springs are devices that store and release energy by undergoing elastic deformation when subjected to external forces. They are widely used in machines and mechanisms for various purposes, such as cushioning, damping, controlling, supporting, lifting, or protecting. Depending on the direction and magnitude of the force and deflection, springs can be classified into four main types: compressive springs, tensile springs, radial springs, and torque springs.

Spring Type – Based on Force or Displacement Direction

- Compressive springs are designed to resist axial compressive forces and shorten when loaded. They are commonly used in shock absorbers, valves, switches, and clutches.
- Tensile springs are designed to resist axial tensile forces and elongate when loaded. They are commonly used in door handles, locks, scales, and toys.
- Radial springs are designed to resist radial forces and expand or contract radially when loaded. They are commonly used in seals, bearings, and brakes.
- Torque springs are designed to resist rotational or twisting forces and produce angular displacement when loaded. They are commonly used in clocks, watches, hinges, and wind-up toys.

Spring Types by Shape

Springs can also be classified based on their shape and geometry.

Helical Extension

Spring

Helical extensions
spring with mass.

- Helical springs are the most common type of springs and consist of a wire coiled into a helix shape. They can be further divided into compression springs, extension springs, drawbar springs, and torsion springs based on their function. Compression springs are helical springs that resist compressive forces and have a gap between the coils when unloaded. Extension springs are helical springs that resist tensile forces and have hooks or loops at the ends to attach to other

components.

- Drawbar springs are a special type of extension springs that have a rigid rod running through the center of the coils and limit the maximum extension. These can help ensure safety by limiting over extension. For example.
- Torsion springs are helical springs that resist twisting forces and have two arms or legs at the ends to apply torque.
- Leaf springs are flat strips of metal stacked together and clamped at the center. They are used to support heavy loads and absorb shocks in vehicles.
- Belleville springs are conical washers that can be stacked together to create different load-deflection characteristics. They are used to maintain a constant force or preload in bolts, valves, clutches, etc .

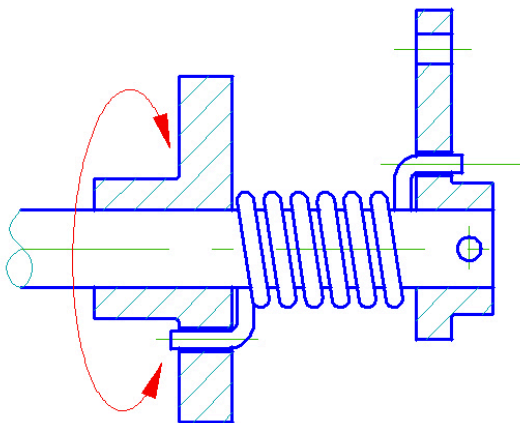

Torsion springs resist torques and generate angular displacement.



Leaf springs are often used in automotive applications to support the wheel axles.

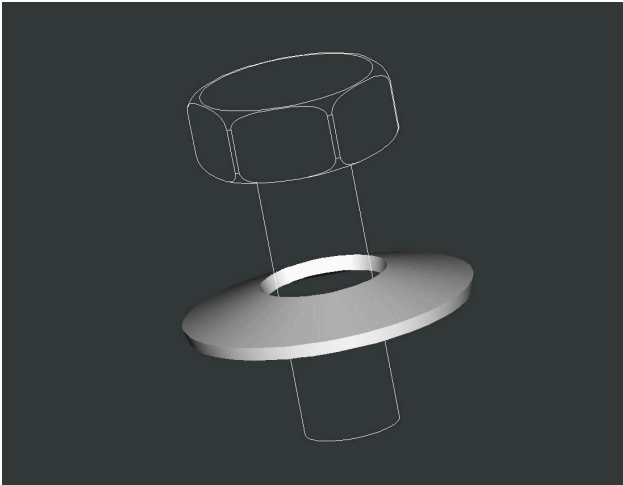

A Belleville washer or spring adds force to a bolt to help keep the nut from loosening.

Spring Selection from a Supplier

When designing a spring for a specific application, it is essential to select the appropriate spring parameters that match the design requirements and constraints. These parameters include the material, wire diameter, spring index, spring rate, free length, number of coils, maximum force or deflection.

- The material affects the strength and durability of the spring, as well as its resistance to corrosion and fatigue. Common spring material.
- The wire diameter determines the cross-sectional area of the spring wire, which influences the stiffness and weight of the spring.
- The spring index is the ratio of the mean coil diameter to the wire diameter. It affects the stability and manufacturability of the spring.
- The spring rate is the stiffness of the spring, which determines how much force is needed to deform the spring by a certain amount.
- The free length is the length of the spring when it is not under any load. It affects the initial position and preload of the spring.
- The number of coils is the number of turns in the spring coil. It affects the length and weight of the spring.
- The maximum force or deflection is the limit of the load or displacement that the spring can withstand without permanent deformation or failure.

Springs can be purchased from a supplier either as standard parts from a catalog or as special ordered parts for unique applications. Standard springs are mass-produced springs that have standard dimensions and

specifications. They are usually cheaper and readily available than custom-made springs. However, they may not meet all the design requirements or fit well in some situations. Special ordered springs are custom-made springs that have specific dimensions and specifications according to the customer's request. They are usually more expensive and take longer to produce than standard springs. However, they can offer better performance and compatibility for some applications.

Many spring manufacturer produce catalogs of products that also include helpful information on how to select the right spring for your application.

Look at the catalog here: [Compression Spring Stock Catalog – Over 40,000 Springs in Stock](#)

Questions:

- What are the parameters that you would need to know to find a set of suitable springs?
- What is the relationship between the material you select and force limits for springs made of that material?

Process for Spring Selection

The process for selecting a spring depends first on the type of force and motion. Selecting between compression, tensile or torque springs depends on the desired force and deflection direction. Then a designer needs to find the spring or springs that will satisfy the constraints of their design situation. Hopefully this results in multiple possible solutions and the designer selects the best cost for performance spring. However, sometimes a custom spring needs to be ordered to meet very tight design constraints.

Let's look at specifying a helical compression spring as an example. To find a compression spring from a catalog based on the maximum force (or deflection) and largest coil size allowable (housing size):

1. Determine the maximum force that the spring will be subjected to in your application. This is the load that the spring must support without exceeding its elastic limit or buckling. The maximum deflection and maximum load should not be the absolute maximum of the spring. Rather, you will also need to include a small allowance to ensure that under extreme or unexpected situations the spring does not go solid (all coils in contact).
2. Determine the largest coil size that can fit in your design space. This is the outer diameter of the spring plus the clearance needed for installation and operation.
3. Look for springs in the catalog that have a load rating equal to or greater than the maximum force and an outer diameter equal to or smaller than the largest coil size.

4. Compare the other specifications of the springs, such as free length, solid length, spring rate, material, finish, etc., and choose the one that best suits your needs and preferences.

For example, suppose you need a compression spring that can support a maximum force of 100 N and fit in a space with a diameter of 20 mm. You can look for springs in the catalog that have a load rating of 100 N or more and an outer diameter of 20 mm or less. You may find several options, such as:

- A spring with a load rating of 105 N, an outer diameter of 18 mm, a free length of 50 mm, a solid length of 25 mm, a spring rate of 7 N/mm, made of stainless steel and coated with zinc.
- A spring with a load rating of 110 N, an outer diameter of 19 mm, a free length of 40 mm, a solid length of 20 mm, a spring rate of 9 N/mm, made of carbon steel and painted black.
- A spring with a load rating of 120 N, an outer diameter of 20 mm, a free length of 60 mm, a solid length of 30 mm, a spring rate of 6 N/mm, made of alloy steel and plated with nickel.

Depending on your application requirements and preferences, you can choose one of these springs or look for other alternatives in the catalog.

Some of the other choices include the coatings on the exterior or treatments that help increase the fatigue life of the spring and how the ends are shaped to ensure consistent contact and force distribution between surfaces. For example, compression springs with ground and flat ends have two parallel planes at the consequence of losing some of the spring capacity. Additionally, there can be some limits on the material choice based on application that need corrosion resistance or other properties.

Wrapping Up Spring Selection:

What are spring coatings and treatments and what do they do? – [Read On](#)

How does the application context influence spring material choice? – [Read On](#)

Can you differentiate between: coil diameter and mean diameter? How about length, coils, and end treatments? – [Read On](#)

MOTORS AND CONTROLLERS

Motors are devices that convert electrical energy into mechanical energy, or vice versa for generators. There are two main types of motors: AC and DC powered motors. AC motors operate on alternating current, which changes its direction and magnitude periodically, while DC motors operate on direct current, which has a constant direction and magnitude.



AC Motors are commonly used in industrial applications such as manufacturing lines.

DC motors are widely used in various applications that require precise control, high torque, or variable speed. There are different types of DC motors, such as geared motors, stepper motors, and servos.

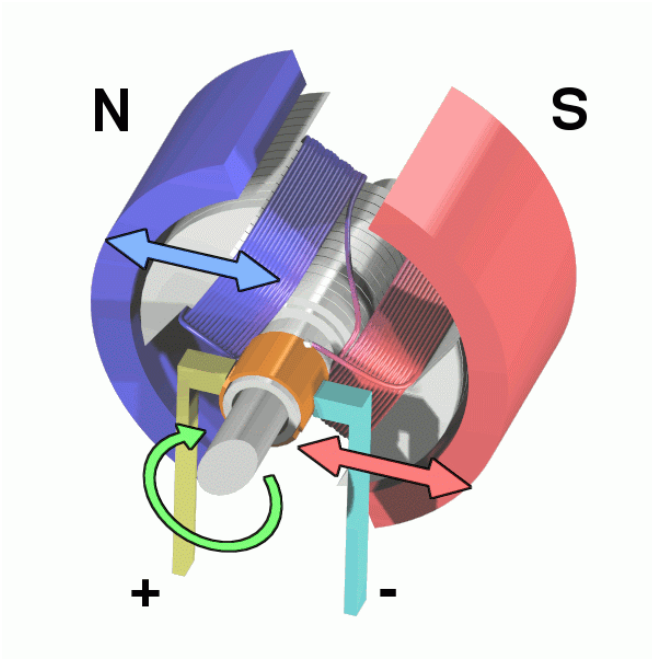

A DC motor works by an alternating magnetic field which generates a torque.

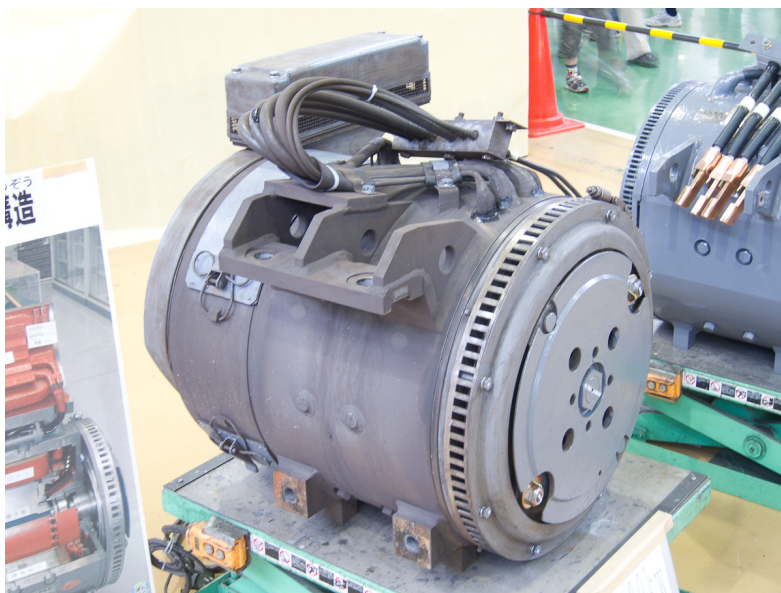
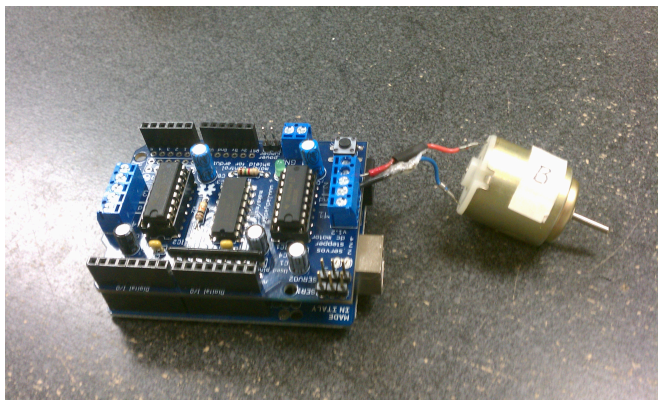

Large kW DC motors are used in industrial and transportation domains.

Geared motors are DC motors that have a gearbox attached to them, which reduces the speed and increases the torque of the output shaft. Geared motors are suitable for applications that require high torque at low speed, such as conveyor belts, elevators, or robots.

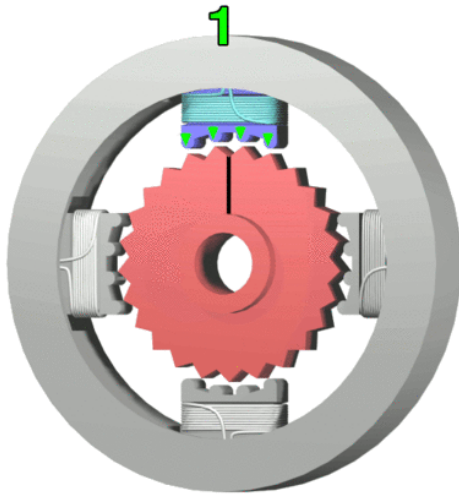

Stepper motors provide precise rotational control.

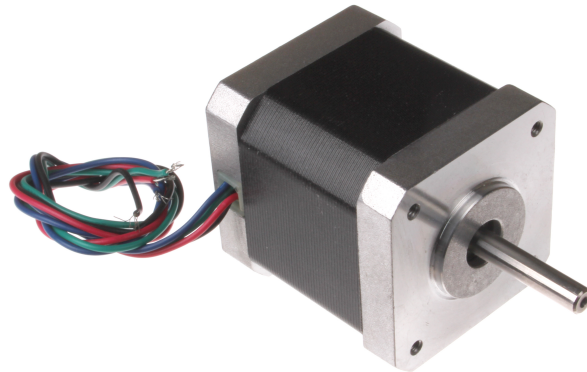

Stepper motors can be found on many manufacturing machines such as 3D printers, linkages systems and other manufacturing lines.

Stepper motors are DC motors that rotate in discrete steps, which can be controlled by pulses of current. Stepper motors are ideal for applications that require accurate positioning, such as printers, scanners, or CNC machines.

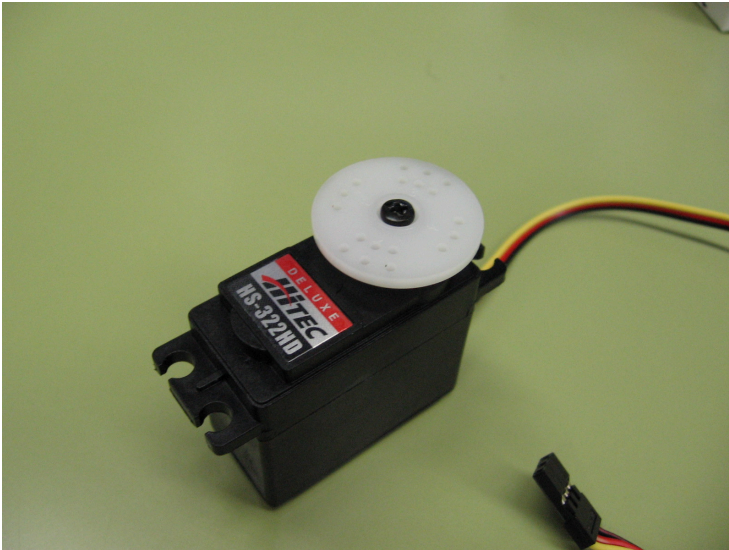

Servo motors are used for precise motions in many robotic applications.

Servos are DC motors that have a feedback mechanism that allows them to adjust their position and speed according to a signal from a controller. Servos are commonly used for applications that require precise angular movement, such as robotic arms, cameras, or antennas.

When selecting a motor for a mechanical design, there are several factors to consider, such as the required speed, torque, power, efficiency, size, shape, cost, and reliability. Depending on the application and the specifications, different types of motors may be more suitable than others. Therefore, it is important to understand the principles of motor selection and compare the advantages and disadvantages of each motor option.

- AC Motors – Large applications, high efficiency, precise control of continuous rotational speed.
- DC Geared Motors – Smaller sizes, within product or system, precise control of continuous rotation
- Stepper Motors – High torque holding capacity, precise control of rotation angle or rotational position.
- Servo Motors – Inexpensive limited rotational motion, precise control of limited range of motion (commonly 180 degrees).

How Do Motors Even Work?



One or more interactive elements has been excluded from this version of the text. You can view them online here: <https://uark.pressbooks.pub/mechanicaldesign/?p=161#oembed-1>

Motor Specification

DC Geared Motors

The speed and torque of a DC motor are determined by its voltage, current, resistance, and armature constant. The armature constant for a dc motor is a parameter that relates the torque produced by the motor to the current flowing through the armature. The armature constant is also known as the torque constant or the motor constant. The armature constant can be calculated by dividing the torque by the current, or by multiplying the back emf constant by the motor efficiency. The armature constant depends on the design and construction of the motor, such as the number of turns, the length and cross-sectional area of the wire, and the magnetic flux density.

The following formula can be used to calculate the speed and torque of a DC motor:

$$\text{Speed (in rpm)} = (\text{Voltage} - \text{Current} * \text{Resistance}) / \text{Armature constant}$$

$$\text{Torque (in Nm)} = \text{Current} * \text{Armature constant}$$

To select a DC motor, we need to know the desired speed and torque of the system, as well as the available voltage and resistance. Then, we can use the formula to find the current and armature constant of the motor. Alternatively, we can look up the specifications of different motors and compare them with our requirements.

A supplier or manufacturer can provide you with the specific speed/torque curves for a

particular motor. See the guide from ISL here: [How To Read DC Motor & Gear Motor Performance Curves | ISL Products](#)

For example, suppose we want to design a system that needs a speed of 3000 rpm and a torque of 0.5 Nm. We have a voltage source of 12 V and a resistance of 1 ohm. Using the formula, we can find that the current and armature constant of the motor should be:

$$\text{Current} = (\text{Voltage} - \text{Speed} * \text{Armature constant}) / \text{Resistance}$$

$$\text{Armature constant} = (\text{Voltage} - \text{Current} * \text{Resistance}) / \text{Speed}$$

Plugging in the values, we get:

$$\text{Current} = (12 - 3000 * \text{Armature constant}) / 1$$

$$\text{Armature constant} = (12 - \text{Current} * 1) / 3000$$

Solving for Current and Armature constant, we get:

$$\text{Current} = 0.004 \text{ A}$$

$$\text{Armature constant} = 0.004 \text{ Nm/A}$$

Therefore, we need to select a DC motor that has a current rating of 0.004 A and an armature constant of 0.004 Nm/A. We can search for such a motor online or in a catalog and check its other features, such as size, weight, efficiency, etc.

Stepper Motors

A stepper motor is a type of electric motor that can rotate in discrete steps, which makes it suitable for precise positioning and speed control. To select a stepper motor for a machine application, you need to consider the following factors:

- The torque and speed requirements of the load. The torque is the force that the motor can exert on the load, and the speed is the number of revolutions per minute (RPM) that the motor can achieve. The torque and speed are inversely proportional, meaning that as one increases, the other decreases. Therefore, one needs to find a balance between the two that meets the performance criteria of the application.
- The power supply and driver circuit of the motor. The power supply provides the voltage and current that the motor needs to operate, and the driver circuit controls the switching of the coils inside the motor to create the desired motion. The power supply and driver circuit should match the specifications

of the motor, such as the rated voltage, current, phase, and step angle.

- The size and mounting of the motor. The size of the motor determines how much space it occupies in the machine, and the mounting refers to how the motor is attached to the load or the frame. The size and mounting should be compatible with the design and layout of the machine, as well as the environmental conditions, such as temperature, humidity, and vibration.

Supplier websites will help you find the appropriate stepper motor for your application. For example, see: [Selection Guide for Stepper Motors | Motion Control Products](#)

Servos

To select a servo motor for an application, the primary selection factors are: the required torque, speed, accuracy, and feedback. The torque is the rotational force that the motor can produce, and it depends on the load and the inertia of the system. The speed is the rotational velocity that the motor can achieve, and it is related to the voltage and the frequency of the power supply. The accuracy is the degree to which the motor can match the desired position or velocity, and it is influenced by the resolution and the linearity of the feedback device. The feedback device is a sensor that measures the actual position or velocity of the motor and sends it back to the controller, which adjusts the output accordingly. A common feedback device is an encoder, which can be incremental or absolute. An incremental encoder counts the pulses generated by the motor rotation, while an absolute encoder provides a unique code for each position.

Servo motors can be selected from small hobby size to significant holding torques for industrial applications. See an example supplier here: [Shop Industrial Servo Motors – MRO Electric and Supply](#)

Linear Actuation

An electrical linear actuator is a device that converts the rotational motion of an electric motor into linear motion, allowing it to move objects in a straight line. Electrical linear actuators typically consist of an electric motor and a screw mechanism, such as a lead screw, a ball screw, or a roller screw, that translates the rotary motion of the motor into linear displacement. Electrical linear actuators are widely used in various applications, such as industrial machinery, medical equipment, robotics, and automation systems.

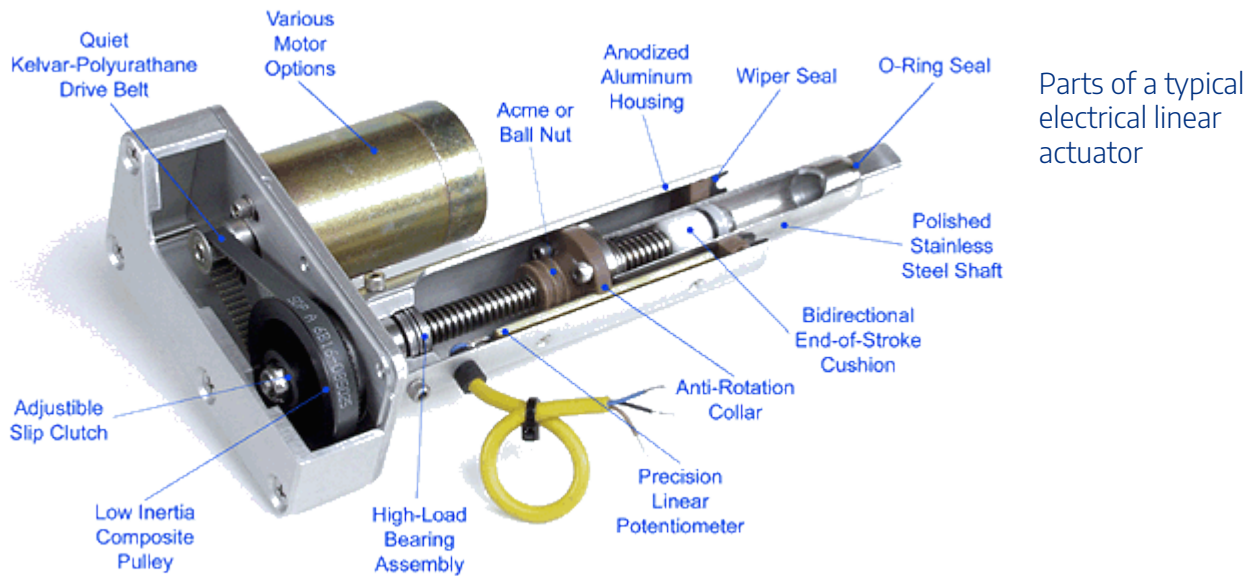

To select an electrical linear actuator for a machine, the controlling factors are: the required force, speed, stroke length, accuracy, repeatability, duty cycle, environmental conditions, and control options.

- The force of an electrical linear actuator is determined by the torque of the motor and the pitch of the screw.
- The speed of an electrical linear actuator is inversely proportional to the force.
- The stroke length of an electrical linear actuator is the maximum distance that the actuator can travel.
- The accuracy and repeatability of an electrical linear actuator depend on the precision and backlash of the screw mechanism.
- The duty cycle of an electrical linear actuator is the percentage of time that the actuator can operate without overheating.
- The environmental conditions of an electrical linear actuator include the temperature, humidity, dust, vibration, and corrosion resistance.
- The control options of an electrical linear actuator include the type of motor (AC or DC), the feedback device (encoder or potentiometer), and the communication protocol (analog or digital).

Electrical linear actuators offer many advantages over other types of actuators, such as hydraulic or pneumatic actuators. They are more energy-efficient, precise, reliable, quiet, clean, and easy to install and maintain. However, they also have some limitations, such as lower force capacity, higher cost, and higher complexity. Therefore, one should carefully evaluate the needs and specifications of the machine before choosing an electrical linear actuator.

Hydraulic or pneumatic linear actuators use pressurized fluid (air or liquid) to drive a piston and achieve linear motion. These actuators can be more powerful and cheaper but come with the added complication

of the supporting hydraulic or pneumatic pressure system. Some examples of where pneumatic or hydraulic linear actuators are used are:

- **Valves:** Pneumatic or hydraulic actuators can control the opening and closing of valves in pipelines, pumps, tanks, etc. They can provide fast and accurate valve positioning, as well as high torque and pressure resistance.
- **Robotics:** Pneumatic or hydraulic actuators can provide smooth and flexible movement for robotic arms, grippers, joints, etc. They can also offer high load capacity, speed, and durability.
- **Automotive:** Pneumatic or hydraulic actuators can operate various components in vehicles, such as brakes, clutches, steering, suspension, etc. They can ensure reliable and safe performance, as well as energy efficiency and noise reduction.

Motor Control

Motor control boards or control drivers are used to regulate the operation of motors. These devices are separate from the control logic boards that provide the instructions for the motor, because high power motors require high power supplies which would be too much for sensitive logic control boards. Motor control is usually accomplished with a packaged motor control board and software solution.

WARP UP - COMMON MECHANICAL COMPONENT SPECIFICATION

Summary of Key Concepts

- Often to achieve a desired function, standard types of components can be used and selected.
- Components Off the Shelf (COTS) are purchased from suppliers and component catalogs are used to specify parameters of the desired component.
- We covered several common mechanical component types, however, there are many different types. The best approach is to find a particular supplier and look at their website and physical or digital catalog to find what you need.

Part 8 Questions



An interactive H5P element has been excluded from this version of the text. You can view it online here:

<https://uark.pressbooks.pub/mechanicaldesign/?p=309#h5p-9>

PART VIII

ASSEMBLIES FOR MOTION AND POWER DELIVERY

Learning Objectives

By the end of this section, students should be able to:

- Understand the terms associated with mechanisms, linkages, gearings and cam systems
- Apply synthesis techniques to develop the form of a useful machine
- Apply analysis techniques to determine the required control needed to achieve a machine's functionality

Summary

Machine design is the process of creating systems that can convert energy into useful work. Engineers design both simple and complex machines for various purposes. A simple machine is a device that changes the direction or magnitude of a force, such as a ramp or a lever. A complex machine is a device that uses movement to perform work, such as a transmission or a robot arm. In this chapter, we will explore some principles and methods of machine design.

For the detailed design stage, one of the first tasks of machine design is to synthesize a machine that can perform a specific function under certain constraints. Synthesis means finding the best possible form and arrangement of the machine elements, such as linkages, gears, springs, etc., to achieve the desired output. For example, if we want to design a machine that can lift a heavy load, we need to consider what type of mechanism can provide enough force and displacement, and how to connect the components to form a stable structure.

The next task of machine design is to analyze the behavior and performance of the machine under various conditions. Analysis means finding the optimal way to control the machine, such as input power and speed, to

achieve the required functionality without violating any other constraints, such as safety, reliability, efficiency, etc. For example, if we want to design a machine that can move parts in a manufacturing process from one area to another, we need to consider how to regulate the motion and speed of the machine, and how to avoid collisions and failures.

The first step in machine detail design is to identify the functions and constraints of the problem. For instance, we may need to specify the size and weight of the parts, the distance and direction of the movement, the time and accuracy required, the available space and resources, etc. The second step is to generate multiple possible solutions that can satisfy the functions and constraints. For instance, we may consider different types of mechanisms, such as linkages, gears, belts, chains, etc., that can provide the necessary movement and force. The third step is to evaluate and compare the solutions based on some criteria, such as cost, feasibility, simplicity, etc., and select the best one. ***Finally, we get to the main point of this chapter;*** to fully define and refine the solution by applying the techniques of synthesis and analysis. For instance, we may need to determine the dimensions and shapes of the machine elements, and the parameters and settings of the control system.

The final outcome of machine detail design is a detailed specification of a machine that can perform the desired work in an efficient and reliable manner.

In this chapter we will explore in detail the three most common types of machines used in mechanical systems, how to synthesize their form and perform analysis to ensure they achieve the desired function within constraints.

MACHINES AND THE CONTROL OF WORK

Franz Reuleaux (1829-1905) was a German mechanical engineer and kinematician. He is considered to be one of the founders of modern kinematics, the study of the motion of mechanisms. Reuleaux made significant contributions to the design and analysis of machines, including the development of new theories and methods for kinematic synthesis. He also wrote extensively on kinematics and machine design, and his books are still considered to be classics in the field. Much of the terms for machines come from Reuleaux work. Reuleaux define a machine as a “combination of resistant bodies so arranged that by their means the mechanical forces of nature can be compelled to do work accompanied by certain determinate motions.”

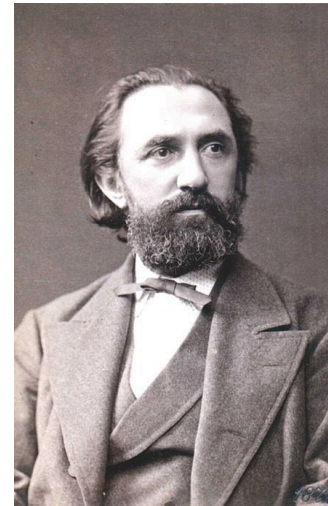

Franz Reuleaux
https://en.wikipedia.org/wiki/Franz_Reuleaux

Intro to Machine/ Mechanism Design

Machine design is the process of creating systems that can convert energy into useful work. Engineers design both simple and complex machines for various purposes. A simple machine is a device that changes the direction or magnitude of a force, such as a ramp or a lever. A complex machine is a device that uses movement to perform work, such as a car or a robot. In this chapter, we will explore some principles and methods of machine design, using examples from different fields of engineering.

One of the main tasks of machine design is to synthesize a machine that can perform a specific function under certain constraints. Synthesis means finding the best possible form and arrangement of the machine elements, such as linkages, gears, springs, etc., to achieve the desired output. For example, if we want to design a machine that can lift a heavy load, we need to consider what type of mechanism can provide enough force and displacement, and how to connect the components to form a stable structure.

Another important task of machine design is to analyze the behavior and performance of the machine under various conditions. Analysis means finding the optimal way to control the machine, such as input power and speed, to achieve the required functionality without violating any other constraints, such as safety, reliability,

efficiency, etc. For example, if we want to design a machine that can move parts in a manufacturing process from one area to another, we need to consider how to regulate the motion and speed of the machine, and how to avoid collisions and failures.

To illustrate the process of machine design, let us consider a motivating example: We need to design a machine that can move parts in a manufacturing process from one area to another. The first step is to identify the functions and constraints of the problem. For instance, we may need to specify the size and weight of the parts, the distance and direction of the movement, the time and accuracy required, the available space and resources, etc. The second step is to generate multiple possible solutions that can satisfy the functions and constraints. For instance, we may consider different types of mechanisms, such as linkages, gears, belts, chains, etc., that can provide the necessary movement and force. The third step is to evaluate and compare the solutions based on some criteria, such as cost, feasibility, simplicity, etc., and select the best one. The fourth step is to refine and optimize the solution by applying the techniques of synthesis and analysis. For instance, we may need to determine the optimal dimensions and shapes of the machine elements, and the optimal parameters and settings of the control system.

The final outcome of machine design is a detailed specification of a machine that can perform the desired work in an efficient and reliable manner. Machine design is an iterative and creative process that requires both theoretical knowledge and practical skills. In this chapter, we will introduce some fundamental concepts and methods of machine design that can help engineers solve various engineering problems.

LINKAGES AND MECHANISMS

Watch and Follow Along with Dr. Slocum – FUNdaMENTALS of Design – Links

Watch Dr. Slocum's Video below. You can follow along with the slides and images here.

FUNdaMENTALS of Design – Links

A Wide World of Mechanisms

Ready to be blown away by what is possible out there?

Explore Dr. Nguyen Duc Thang Youtube channel to see all the 1000's of mechanisms he has generated and animated.

<https://www.youtube.com/@thang010146/videos>

Links, Joints, and Terminology of Linkages

The study of the mathematics of machines, sometimes called theory of machines, focusses on how to generate

linkages to achieve a desired conversion of power to achieve a desired function. As with any field of study there are specific terms we will need to cover.

Kinematic chain	A kinematic chain is a group of links connected by joints. A kinematic chain can be open or closed. An open kinematic chain has at least one free link, meaning that it is not connected to any other links. A closed kinematic chain has no free links.
Mechanism	A mechanism is a kinematic chain with at least one fixed link. A kinematic chain is a group of links connected by joints. A link is a rigid body that can move relative to other links. A node is a point where two or more links are connected.
Links	Links are the rigid bodies that make up a kinematic chain. Links can be any shape or size, but they must be rigid enough to withstand the forces that are applied to them.
Nodes	Nodes are the points where two or more links are connected. Nodes can be simple, such as a pin joint, or they can be complex, such as a cam and follower joint.
Binary links	Binary links are links that are connected to two other links. Most links in a kinematic chain are binary links. A link with two nodes is the least number a link can have and still be considered a link.
Trinary links	Trinary links are links that are connected to three other links. Trinary links are less common than binary links, but they can be used to create more complex mechanisms. There are other named links (for example quaternary links) based on the number of nodes as well.
Joints	Joints are the connections between links. Joints allow links to move relative to each other. There are many different types of joints, each of which allows a different type of motion.
Degrees of freedom	The degrees of freedom of a mechanism are the number of independent motions that the mechanism can make. The degrees of freedom of a mechanism are determined by the number of joints and the type of joints in the mechanism.
Planar Mechanism	A planar mechanism is a system of linkages whose motion is constrained to a two-dimensional plane. This means that all of the relative motions of the parts are in the same plane or in parallel planes.



A simple four-bar linkage is a mechanism with four binary links and four pin joints. It has one degree of freedom. The oil rig shown is a 4-bar mechanism.

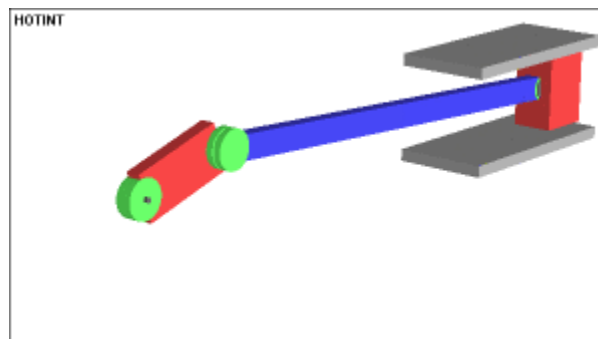

A slider-crank mechanism is a mechanism with four binary links and four joints: three pin joints and one slider joint. It has one degree of freedom.

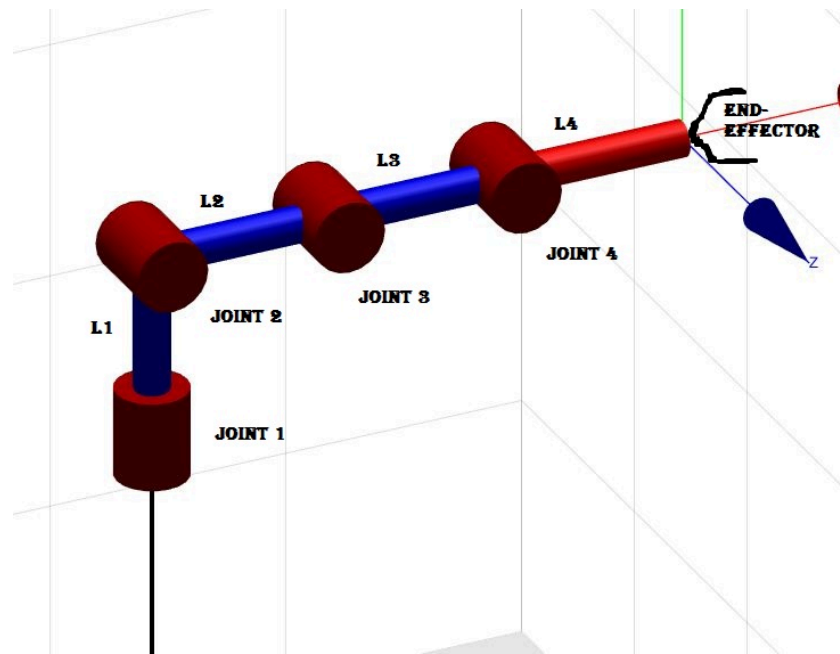

A robot arm is a complex mechanism with many links and joints. It can have up to six DOF.

Common Types of Mechanisms

Cornell University has an incredible collection of mechanisms that you should plan to visit in person someday but ALSO has freely available images and animations to view: [Reuleaux Kinematic Mechanisms Collection](#) | Cornell University Library Digital Collections.

General Model Classes (Voigt Taxonomy)

<p>From the Cornell University Kinematics Models for Design Digital Library</p> <ul style="list-style-type: none"> A. Lower Element Pairs B. Higher Element Pairs C. Simple Kinematic Chains D. Crank Mechanisms E. Excentric Slider Cranks F. Crank Chamber Mechanisms G. Simple Gear Trains H. Model Support Pedestals I. Chamber Wheel Mechanisms K. Complex Slider Crank Mechanisms L. Positive Return Constant Breadth Cams M. Screw Mechanisms 	<ul style="list-style-type: none"> N. Ratchet Mechanisms O. Planetary Gear Trains P. Jointed Couplings Q. Gear Teeth Profiles R. Cycloid Rolling Models S. Straight-line Mechanisms T. Parallel Guide Mechanisms U. Rotating Arm Guide Mechanisms V. Belt Drive Mechanisms W. Friction Wheels X. Clock Escapements Y. Reversing and Shifting Belt and Gear Mechanisms Z. Coupling Mechanisms
--	---

Special Linkage Mechanisms

There are a few common linkage mechanisms used in many different kinds of mechanical products and systems to achieve the desired functions.

Common Linkage Mechanism in Machines

Ratchet and Escapement

A ratchet mechanism is a device that allows continuous motion in one direction, while preventing motion in the opposite direction. It consists of two main parts: a ratchet wheel (or gear) with teeth on one side, and a pawl that engages with the teeth. The pawl is spring-loaded, so it presses against the teeth of the ratchet wheel and prevents it from moving backward. When force is applied to the ratchet wheel in the forward direction, the pawl slides over the teeth and allows the wheel to rotate. However, when force is applied in the backward direction, the pawl catches against the teeth and prevents the wheel from rotating. An escapement mechanism is a device that controls the release of energy in a mechanical system, such as a clock or watch. It works by allowing the system's timekeeping element (usually a pendulum or balance wheel) to oscillate back and forth, while transferring energy from the system's power source (usually a spring or weight) to the timekeeping element at a regular pace. This keeps the timekeeping element oscillating at a constant frequency, which allows the system to keep accurate time.



One or more interactive elements has been excluded from this version of the text. You can view them online here: <https://uark.pressbooks.pub/mechanicaldesign/?p=143#oembed-1>

Indexing

An indexing mechanism (like the Geneva mechanism shown) is a device that allows a shaft or other rotating element to be positioned in precise increments. It works by using a series of evenly spaced teeth or slots to engage with a follower pin or other indexing element. As the rotating element turns, the follower pin engages with the teeth or slots and indexes the element forward one step at a time.



One or more interactive elements has been excluded from this version of the text. You can view them online here: <https://uark.pressbooks.pub/mechanicaldesign/?p=143#oembed-2>

Swinging or Rocking

A swinging or rocking 4-bar mechanism is a type of linkage that converts rotary motion into oscillating motion. It consists of four links connected together by four joints, with one of the links fixed to a frame. The other three links are free to move, and the link that oscillates is called the rocker. When the input link is rotated, it drives the other links to move, causing the rocker to swing or rock. The angle of the rocker is determined by the lengths of the links and the input angle.

In windshield wipers, the swinging or rocking 4-bar mechanism is used to convert the rotary motion of a motor into the back-and-forth motion of the wiper blades.



One or more interactive elements has been excluded from this version of the text. You can view them online here: <https://uark.pressbooks.pub/mechanicaldesign/?p=143#oembed-3>

Reciprocating

A reciprocating mechanism is a device that converts rotary motion into linear motion. It consists of a rotating element (such as a crank or cam) and a sliding element (such as a piston or plunger). The rotating element drives the sliding element back and forth, creating reciprocating motion. Quick-return is a design feature of some reciprocating mechanisms that allows the return stroke (the stroke in which the sliding element moves back to its starting position) to be completed faster than the working stroke (the stroke in which the sliding element performs its useful work). This is achieved by designing the mechanism so that the sliding element travels a shorter distance and/or at a higher speed during the return stroke.

The advance-to-return ratio is a measure of how much faster the working stroke is than the return stroke. It is calculated by dividing the distance traveled during the working stroke by the distance traveled during the return stroke. A ratio greater than 1 indicates a quick-return mechanism.



One or more interactive elements has been excluded from this version of the text. You can view them online here: <https://uark.pressbooks.pub/mechanicaldesign/?p=143#oembed-4>

Curve Generator

A curve generating mechanism is a device that converts rotary motion into a curved path. It consists of a number of interconnected links that move the end of one link in a curved path as the input link is rotated. Curved path guiding is often needed in manufacturing machines to guide product through operations at a constant rate.



One or more interactive elements has been excluded from this version of the text. You can view them online here: <https://uark.pressbooks.pub/mechanicaldesign/?p=143#oembed-5>

Straight-Line Generator

A straight line generating mechanism is a device that converts rotary motion into linear motion with very little deviation from a straight line. It does this by using a system of linkages to constrain the motion of a point to a straight line.

One common type of straight line generating mechanism is the Peaucellier-Lipkin inversor. This mechanism consists of four links connected together by four joints. The input link is rotated by a motor, and the other three links are constrained to move in a straight line. The point at which the three links intersect traces out a straight line as the input link is rotated.

Another common type of straight line generating mechanism is the Watt's linkage. This mechanism is similar to the Peaucellier-Lipkin inversor, but it is simpler to design and manufacture. However, it does not produce as accurate of a straight line as the Peaucellier-Lipkin inversor.



One or more interactive elements has been excluded from this version of the text. You can view them online here: <https://uark.pressbooks.pub/mechanicaldesign/?p=143#oembed-6>

MOTION AND CONTROL OF MECHANISMS

Degrees of Freedom and Mobility

Joints

Mechanisms and other kinematic chains are made of linkages that are connected together at joints. The type of joint defines how the bodies are allowed to move with respect to each other. A free-floating object in space has six degrees of freedom (DOF), meaning that it can translate in three directions and rotate about three arbitrary orthogonal axes. When bodies or links are joined together, they impose restrictions on the motions that are allowed, reducing the DOF of the entire object.

Joints are described based on the DOF they allow. There are six types of joints called **lower pairs**:

- **Revolute joint:** Allows one DOF, rotation.
- **Prismatic joint:** Allows one DOF, translation.
- **Screw or helical joint:** Allows one DOF, a combination of rotation and translation.
- **Cylindrical joint:** Allows two DOF, rotation and translation along a common axis.
- **Spherical joint:** Allows three DOF, rotation about three orthogonal axes.
- **Flat surface joint:** Allows two translations and one rotation.

Common **higher-order pairs** involve objects with rolling contact, such as gear teeth meshing, cam and follower action, and other rolling elements. There is an unlimited number of possible higher-order pairs, and thus no standard classification for them.

Planar and Spatial Motion

Planar and spatial mechanisms are two broad categories of mechanisms that are distinguished by the dimensionality of their motion. Planar mechanisms are constrained to move in a single plane or in parallel planes, while spatial mechanisms can move in three dimensions.

Planar Mechanisms

Planar mechanisms are very common in engineering applications, and they can be used to create a wide variety of machines and devices. Planar mechanisms are often simpler to design and analyze than spatial mechanisms, and they can be more efficient and reliable in operation. All motion in planar mechanisms is

restricted to two translation directions and one rotation direction. This means that planar mechanisms can be readily synthesized and analyzed using graphical or computational methods in a plane (such as by hand on a piece of paper).

Spatial Mechanisms

Spatial mechanisms are more complex than planar mechanisms, but they offer greater flexibility and versatility. Spatial mechanisms are often used in applications where three-dimensional motion is required, such as robotics, aerospace engineering, and machine tools.

Characteristic	Planar Mechanism	Spatial Mechanism
Dimensionality of motion	Constrained to a single plane or in parallel planes	Free to move in three dimensions
Complexity	Simpler to design and analyze	More complex to design and analyze
Efficiency and reliability	More efficient and reliable	Less efficient and reliable
Versatility	Less versatile	More versatile

While planar mechanisms are constrained to move in a single plane or in parallel planes, there are ways to use them to achieve three-dimensional motion. For example, scissor lifts use two planar four-bar linkages in parallel planes to create a stable lifting platform. Another example is a parallel manipulator, which uses four planar four-bar linkages to create a six-DOF robot arm.

Mobility

The mobility of a linkage mechanism is the number of independent inputs required to define the configuration of all the links. In other words, it is the number of degrees of freedom of the mechanism. The mobility of a linkage mechanism can be determined using the Chebychev–Grübler–Kutzbach equation, which is given by:

$$M = 3(L - 1) - 2J - H$$

where:

- M is the mobility of the mechanism
- L is the number of links in the mechanism
- J is the number of joints in the mechanism
- H is the number of higher-order pairs in the mechanism

Higher-order pairs are joints that allow more than one degree of freedom, such as gear teeth meshing and cam and follower action.

Example

Consider a simple four-bar linkage, which has four links and four revolute joints. The Chebychev–Grübler–Kutzbach equation for this mechanism is:

$$M = 3(4 - 1) - 2(4) - 0 = 1$$

Therefore, the mobility of the four-bar linkage is one, meaning that it has one degree of freedom.

Why does the mobility of a mechanism matter to the machine designer? Because the DOF of the mechanisms is exactly the same as the number of independent drivers needed to control the motion. Can I achieve the motion I want with only 1 motor? Yes, if and only if the degrees of freedom of the machine using the mobility equation is equal to 1.

What if you apply the above mobility equation and come up with a number that you do not want? A mobility of zero means you have designed a structure. A mobility greater than 1 may be acceptable. You can utilize additional controlled actuation like motors or add some forcing element such as a spring. This latter approach is often used to ensure that a follower stays in contact with a cam as the otherwise the DOF would be greater than 1.

By studying the mobility equation, the designer can see that there are some principles that can be used to achieve a desired mobility. These principles are:

1. You can replace joint types without affecting the mobility of the mechanism as long as the joints have the same DOF. For example, you can replace a revolute joint with a prismatic joint to go from a rocking motion to a sliding motion and still drive the machine with one actuator. However, for a planar mechanism, there must be at least 2 revolute joints in order for the mechanism to move at all.
2. If you replace lower pair with a higher order pair you will increase the total DOF by 1. For example, replacing a pin in a hole (revolute) with a pin in a slot moves from just rotation to rotation and translation.
3. Removing a link result in decreasing the mobility by 1 DOF. Thus, if you change a joint to a higher order and remove a link this results in mechanism with the same mobility.
4. If you decrease the number of nodes on a link that has 3 or more nodes by having 1 node connect 2 or more links together, there is no change to the mobility. This means that a link shape can be changed to combine links to join together at the same location. Note, this will change the resulting motion of the machine.
5. If you take the step above to the extreme and combine all links together at 1 joint, you have effectively eliminated a link and the result is a decrease in mobility by 1 DOF.

Grashoff and Mechanism Actuators

Four-bar linkages are one of the most common types of linkage mechanisms. They are composed of three links

(crank, coupler, and follower) and a ground link (the distance between ground points). The link names are shown in the figure below.

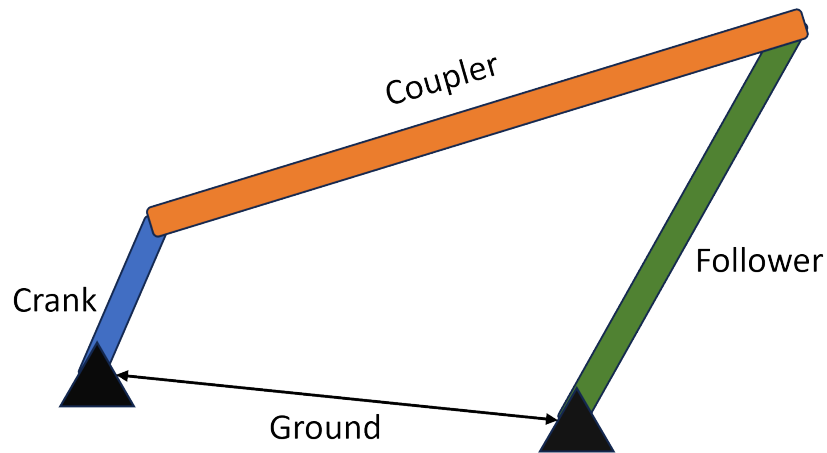

The terms for a 4-bar mechanism. Usually the mechanism is driven by the “crank” but not always.

Open the following and try changing the link lengths. You can drag any of the end points of the links and see how it moves.

1. Find a combination of link lengths where one of the links draws a full circle. Then change the link lengths so that none of the links show complete circles (only arcs).
2. What do you notice about the mechanisms that fully rotate and ones that don't?

<https://www.geogebra.org/classic/BueCGgch>

Many linkage mechanisms are used for consistent, reliable, and repeated actions at a constant rate. One way to achieve this is to drive or actuate the mechanism with something that is consistent and reliable such as a motor operating a constant speed.

The Grashof criterion is a mathematical test that can be used to determine whether a four-bar linkage can achieve continuous rotation. It is named after its inventor, Franz Grashof, a German engineer who lived in the 19th century.

The Grashof criterion states that for a four-bar linkage to be capable of continuous rotation, the sum of the

shortest and longest link lengths must be less than or equal to the sum of the remaining two link lengths. In mathematical terms, this can be expressed as follows:

$$S + L \leq P + Q$$

where:

- S is the shortest link length
- L is the longest link length
- P is the medium link length
- Q is the remaining link length (it doesn't matter which is which for P and Q)



If the Grashof criterion is not satisfied, then none of the links can fully rotate. From a practical control standpoint, that means you cannot easily drive the motion using a continuous rotating motor. Instead, you might need something that oscillates from one position to another, an electrical servo for example.

The different classes of Grashof mechanisms are:

- **Crank-rocker:** In a crank-rocker mechanism, the shortest link is the crank, and the longest link is the rocker. This type of mechanism is used to convert rotary motion into oscillating motion. Examples of crank-rocker mechanisms include the crank-slider mechanism and the slider-crank mechanism.
- **Double-crank:** In a double-crank mechanism, both the shortest and longest links are cranks. This type of mechanism is used to convert rotary motion into rotary motion. Examples of double-crank mechanisms include the parallelogram linkage and the Watt's linkage.
- **Double-rocker:** In a double-rocker mechanism, both the shortest and longest links are rockers. This type of mechanism is used to convert oscillating motion into oscillating motion. Examples of double-rocker mechanisms include the butterfly linkage and the contraparallelogram linkage.

A 4-Bar mechanism that is Not-Grashof is known as a **Tripple Rocker**. There are variations of the tripple rocker as well based on which link is shorted.

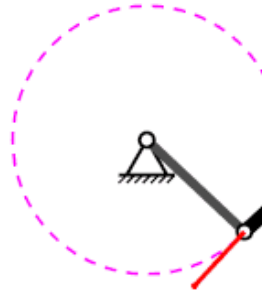
The following table shows how the different classes of Grashof mechanisms are achieved by which link is shortest:

Class	Shortest link	Examples	Animation
Crank-rocker	Crank	Crank-slider mechanism, slider-crank mechanism	
Double-crank	Ground	Parallelogram linkage, Watt's linkage	
Double-rocker	Coupler	Butterfly linkage, contraparallelogram linkage	

It is important to note that the Grashof criterion only applies to four-bar linkages. For five-bar linkages and higher, there is no single criterion that can be used to determine whether the linkage is capable of continuous rotation. However, it is a common practice to make a non-Grashof mechanism into a Grashof mechanism by adding a short crank link and a connector link to a mechanism to drive it. This is called adding a **driver dyad** and will be discussed in the mechanism synthesis section next.

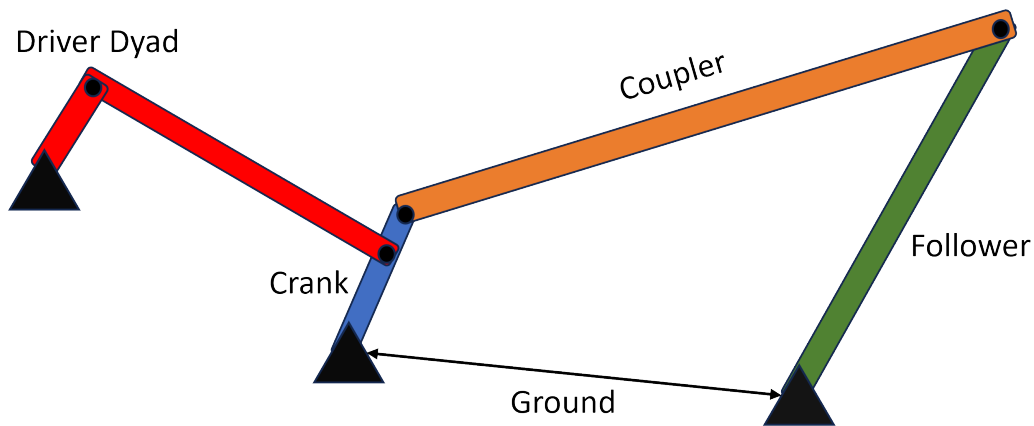

Adding a driver dyad can turn a non-Grashof mechanism into one that can be driven with continuous rotation.

Kinematic Inversion

All for the mechanisms that can be made by keeping the link lengths constant but changing which link is held stationary (the ground link) are known as **kinematic inversions**. Since each link can be held stationary, there are as many inversions as there are links in any given mechanism. Each kinematic inversion of a mechanism will exhibit different motion of the links.



One or more interactive elements has been excluded from this version of the text. You can view them online here: <https://uark.pressbooks.pub/mechanicaldesign/?p=403#oembed-1>

MECHANISM SYNTHESIS

Synthesis of Linkage Mechanisms

Linkage synthesis is the process of designing a linkage mechanism to achieve a desired motion or path. It involves identifying the type of linkage, the desired position of the links, and the length and arrangement of the links. The goal is to create a mechanism that is efficient, accurate, and reliable. It is usually the first step when designing a machine where motion or work is accomplished with a linkage mechanism.

The desired position of the links is determined by the specific task that the linkage mechanism is designed to perform. For example, a linkage mechanism that is used to move a robotic arm will have different position requirements than a linkage mechanism that is used to open and close a door. For spatial mechanisms, the synthesis involves using **Inverse kinematics** to identify what angles of control and link lengths can achieve desired positions. Additionally, a concept called **path planning** is important to avoid collision with other objects. Spatial mechanisms and control are a key topic in robotics. For planar mechanisms, graphical and analytical techniques can be used to synthesize a mechanism.

A secondary goal for synthesis is ensuring the desired type of mechanism actuate is possible. The type of actuator that is used to drive the linkage mechanism depends on the specific requirements of the application. Continuous rotating motors (DC, AC, and stepper motors as an example) are commonly used for applications where the mechanism is Grashof and the driving link can fully rotate. Servos are used for applications where partial rotations are required (often non-Grashof). Linear actuators are used for applications where linear motion is required.

General Synthesis Process

The process of planar mechanism synthesis usually involves the following steps:

1. **Identify the path or location for a link or part of a link.** For example, a grasping component attached to a coupler must move a product on a manufacturing line from one machine to another. The exact location of the desired positions is needed to determine link lengths and grounding locations.
2. **Make design choices for ground location based on the positions or path constraints.** Any four-bar mechanism can be solved as a system of equations based on ground locations and link positions. Therefore, the design freedom to choose where the linkage will be grounded depends on how completely the path must be planned. For example, in “two-position synthesis,” there are an infinite

number of places along two lines where the ground link can be located, while “three-position synthesis” fully constrains the ground locations to two precise points.

3. **Determine the link lengths and ground locations.** Once the link lengths and ground locations are determined, the mechanism is defined. Analysis is then needed to ensure that the mechanism moves as desired, to determine what type of actuation is needed to achieve the desired motion, and to define the shape of the links to avoid interference and meet any performance goals. Recall that links can have any desired shape as long as the distance between nodes stays the same. The linkage will have the same kinematic performance regardless of the shape of the links.

Watch Dr. Slocum’s lecture on Mechanism synthesis below. Follow along on the same document provide on the previous page.

FUNdeMENTALS of Design – Links 2

Graphical Linkage Synthesis

All planar mechanisms can be synthesized (solved) using graphical tools. Paper based methods work well but digital drawing tools allow for more flexibility and accurate drawing.

The following video will provide you with a step-by-step instructions for how to synthesize a mechanisms for various situations. You can either use digital drawing tools like CAD or a pencil, compass, and protractor to follow along on paper. You should follow along, as this is very hard skill to acquire without doing it yourself.



— One or more interactive elements has been excluded from this version of the text. You can view them online here: <https://uark.pressbooks.pub/mechanicaldesign/?p=145#oembed-1>

Computational Synthesis

Analytical methods for planar linkage mechanism synthesis are based on the mathematical relationships between the link lengths and the position and orientation of the links. These methods can be used to synthesize linkage mechanisms for a variety of tasks, such as function generation, path generation, and motion amplification.

There are many tools available to accomplish analytical mechanism synthesis.

One very user friendly one is: MotionGen Pro. The video tutorial series for this software can be found here.

MECHANISM POSTURE AND POSITION ANALYSIS

Critical Position Location Analysis

Position analysis, also called posture analysis is for understanding what combination of angular position of the links lead to positions or postures that are of interest to the designer. Position analysis can be accomplished graphically or analytically. Both methods are about as fast. However, it is recommended that designers always sketch out solutions to verify any computational results.

Minimum Transmission Angle

The **minimum transmission angle** for a planar mechanism is the smallest angle between the input and output links. It is an important measure of the efficiency and performance of a mechanism. A high minimum transmission angle indicates that the mechanism is efficient at transmitting power from the input link to the output link. A low minimum transmission angle can lead to power losses and increased wear and tear on the mechanism. As a general design principle, if the primary objective of the mechanisms is transmitting power or force, than a minimum transmission angle of 45 degrees is best.

For non-Grashof mechanisms, the angle between coupler and follower links can be zero (or 180 degrees). This is an important toggle position that will be discussed below. Thus, the minimum transmission angle is not usually a useful figure of merit for non-Grashof mechanisms. For Grashof mechanism, the minimum transmission angle occurs at one of two postures. The minimum transmission angle can be found when the crank or driver link is at either 0 degree or 180 degrees with respect to ground. Worded another way, when the driver link is colinear with the ground link.

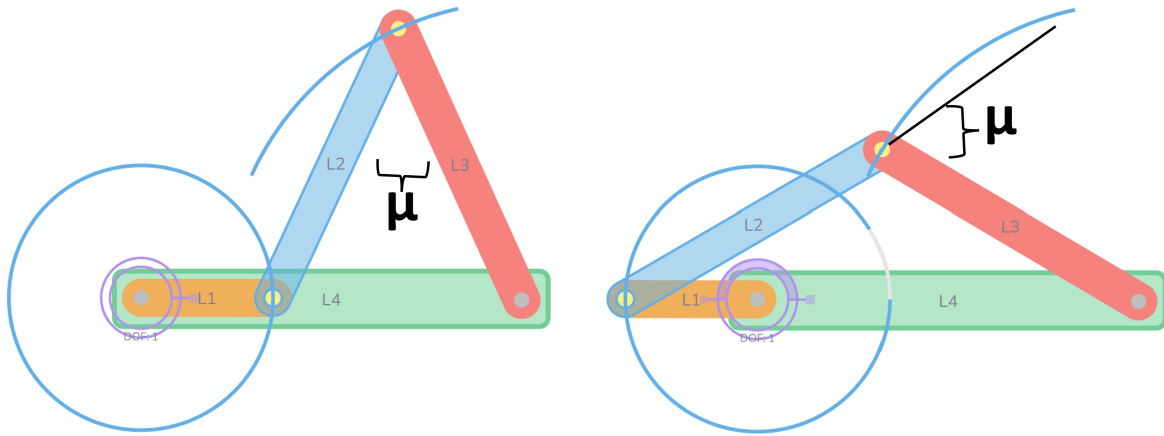

The minimum transmission for a Grashof mechanism is when the driver is at 0 or 180 degrees. The minimum transmission angle (μ) for the mechanism shown is when the driver is at 0 degree with respect to the ground link.

To find the minimum transmission angle, you can utilize graphical techniques such as hand drawing the linkage at a scale or software like MotionGen or CAD. Additionally, you can use the law of cosines if link lengths are known. When links of a 4-bar mechanism are colinear, the resulting shape is a triangle. The law of cosines is usually written as:

$$c^2 = a^2 + b^2 - 2ab * \cos(C)$$

where the **a**, **b**, and **c** are the sides of the triangles and **C** is internal angle across from side c. For a Grashof mechanisms with the driver link colinear with the ground link, the minimum transmission angle can be found by solving the internal angle. Using the labels in the figure above the two possible solutions are:

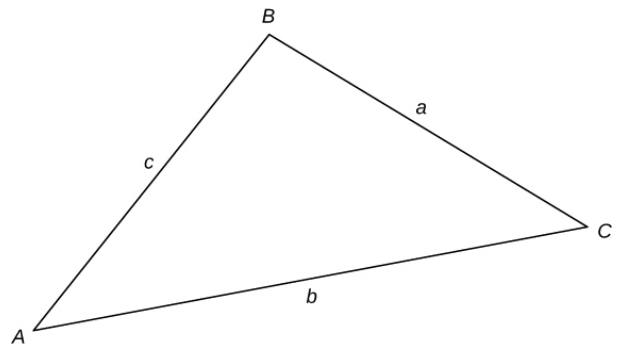

Triangle for the law of sines and law of cosines

$$\cos^{-1}(\mu) = \frac{(Ground - Driver)^2 - L_2^2 - L_3^2}{-2L_2L_3}$$

or

$$\cos^{-1}(\theta) = \frac{(Ground + Driver)^2 - L_2^2 - L_3^2}{-2L_2L_3}$$

$$\mu = 180 - \theta$$

If the minimum transmission angle is larger than about 45 degrees, then changing the link lengths such as increasing the driver length or decreasing the ground link can improve the efficiency of the power transfer of the mechanism.

Toggle Positions

Another special mechanism posture occurs when links are colinear. These positions are called toggle positions. The reason you as machine designer should about toggle positions is that toggle positions are the positions where a mechanism can get stuck and need force to overcome. Additionally, toggle positions can be used to enable a locking type of behavior. For a Grashof mechanism, the toggle position is when the driver and coupler (labeled links 2 and 3 below) are co-linear. If a mechanism is moving slowly it is possible that this posture might result in high amounts of friction. This can be overcome by ensuring that enough force or momentum is provided to the mechanism to pass through this toggle position.

What is often more useful for machine design is toggle positions for non-Grashof mechanisms. The toggle position of coupler and follower (or link 3 and 4 from the image below) can be intentionally designed to provide a locking feature for the mechanism. For example, this is used in linkage mechanisms that support folding table legs and locking pliers. If you have put away a folding table or used a pair of locking pliers you may be familiar with the force needed to knock the mechanism out of the toggle position.

Once again, the law of sines and the law of cosines is useful to determine at what position angle the mechanism will be in a toggle position. Additionally, you can use hand or software tools to draw the mechanisms at toggle position and then measure the angles. These will be very useful when determining how to control and drive the mechanism.

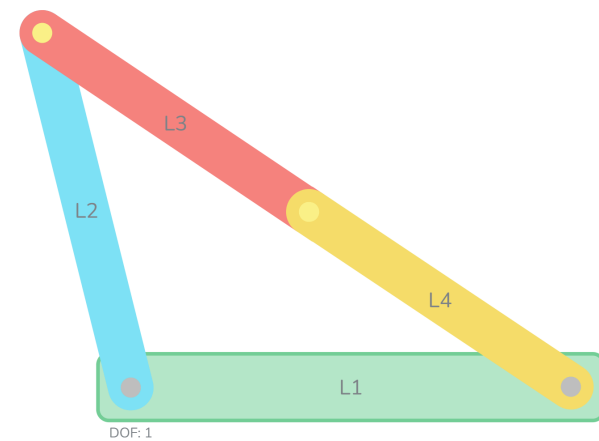
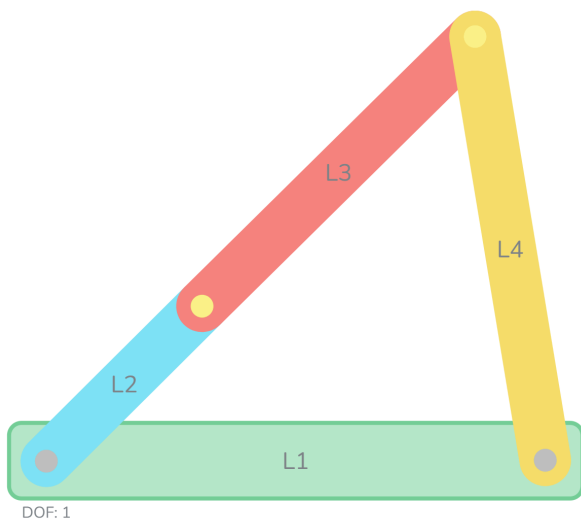

Toggle position for a non-Grashof mechanism

Toggle position for a Grashof mechanism.



Vice grip or locking pliers are an example of a non-Grashof linkage that utilizes the toggle position for functionality.

Link Position and Displacement

Position or displacement analysis for planar mechanisms is the process of determining the position of every link and joint of a mechanism relative to a fixed reference frame. This is an important step in the design and analysis of machines, as it allows the calculation of velocities, accelerations, forces, torques, and other dynamic parameters. Position or displacement analysis can be performed using various methods, such as graphical, analytical, or numerical techniques. Graphical methods involve drawing the mechanism and its links to scale and measuring the position of each point of interest. Analytical methods involve deriving equations that relate the position of each link and joint to the input variables, such as angles or lengths. Numerical methods involve using iterative algorithms or computer software to solve the equations obtained from analytical methods.

Drawing mechanisms by hand to solve for positions is a useful tool for early analysis and enables a designer to see the mechanism shape and anticipate potential trouble areas. Usually, the mechanism is drawn at the extreme positions of interest. However, if the designer wants to explore multiple positions or determine displacement, graphical methods using CAD or other drawing tools will provide more versatility and more accurate measurements. CAD based approaches are also straight forward. Given the link lengths and ground locations, the mechanisms can be virtually manipulated into the desired position and displacements can be measured by the software from those positions.

Analytical or computational position analysis is also common. In the figure below you can see that we can represent a mechanisms as a **vector loop diagram**. That is, if each link was represented as a vector, than we could move from point 0 to point B two equivalent ways. These are:

$$\vec{R}_2 + \vec{R}_3 = \vec{R}_1 + \vec{R}_4$$

This is reorganized for future solving as:

$$0 = \vec{R2} + \vec{R3} - \vec{R4} - \vec{R1}$$

The power of this vector representation is that it can support position, velocity, and acceleration analysis as a system of equations. Euler's formula allows us to represent any of those linkage vectors as:

$$\vec{R2} = R2 * e^{j*\theta_2} = R2 * (\cos \theta_2 + j * \sin \theta_2)$$

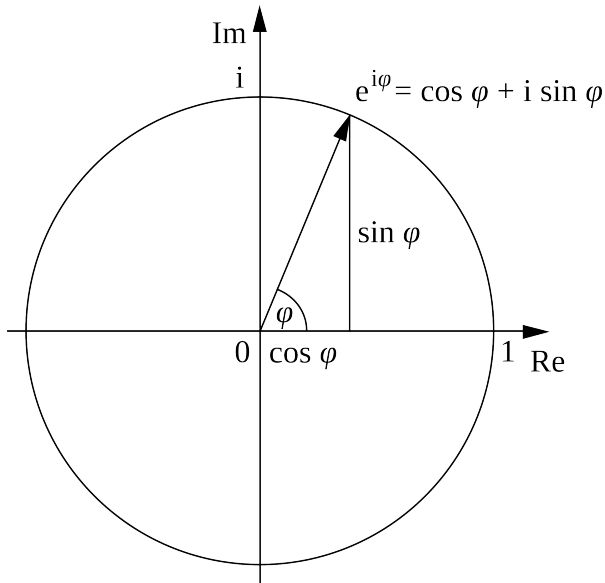

Euler formula allows for two equivalent descriptions of a vector.

Where $R2$ the length of link 2. The term j represents the imaginary component in mathematics which was actually a dismissive term supposedly made by René Descartes. Carl Friedrich Gauss described them as “lateral” which is more useful for our understanding. In this context, the lateral just represent the component in the direction orthogonal to the ground (usually a local y direction).

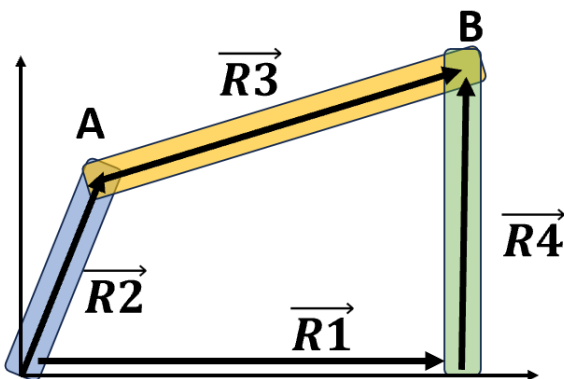

Vector representation of a 4-bar linkage.

Using this approach, an analytical solution can always be found for a mechanism by solving the system of equations for the vector loop by grouping the solutions into the local horizontal (x) and vertical (y) directions. If angle measurements for the links are made with respect to the ground link which defines the local x direction, and recalling that $\cos(0)$ is 1 and $\sin(0)$ is 0, then the two sets of equations can be written below:

In the x direction:

$$0 = R_2 * \cos \theta_2 + R_3 * \cos \theta_3 - R_4 * \cos \theta_4 - R_1 * 1$$

and in the y direction:

$$0 = R_2 * \sin \theta_2 + R_3 * \sin \theta_3 - R_4 * \sin \theta_4$$

With known link lengths (after synthesis, these should be known) and one known angle (such as the driver position angle), the other two angles can be solved and position of the links determined.

Specific solutions for common mechanism are available such as crank-slider mechanisms commonly known as piston equations and there are many general linkage calculator tools available.

As well as the MotionGen software linked above, there are a variety of calculators available to support machine and mechanisms designer.

Softintegration has a variety of web-based tools for solving for synthesis, displacement, and velocity analysis.

Four-Bar Linkage Analysis and Synthesis

The community file exchange for Matlab has many user-built tools for solving 4-bar and similar mechanisms. Additionally, the toolbox called Simscape is very useful for detail modeling when designers know properties of the linkage such as mass and shape and want detailed calculations and simulations.



One or more interactive elements has been excluded from this version of the text. You can view them online here: <https://uark.pressbooks.pub/mechanicaldesign/?p=333#oembed-1>

MECHANISM FORCE, VELOCITY AND ACCELERATION ANALYSIS

Force Analysis

There are two main objectives when considering how forces act on and through a planar mechanism. First, mechanical advantage is figure of merit for a mechanism that represents the effectiveness of turning input torque or force into output torque or forces. Secondly, static and dynamic force analysis is used to understand how forces act on each link in the mechanisms and are transferred to components such as bearings and pins. Both graphical and computational techniques are commonly used for force analysis.

Mechanical Advantage

In general, mechanical advantage related input and output torques. For a gearing system, this is the gear ratio which is constant as long as the diameter of the gears is constant. However, for a linkage mechanism, the mechanical advantage ratio changes as the mechanism moves. Consider the 4-bar linkage below as an example. Mechanical advantage is determined as the ratio of the driver length times the sine of the integral angle and the length of the follower times the sine of its internal angle. As a formula:

$$MA = \frac{L_4 * \sin\lambda}{L_2 * \sin\beta}$$

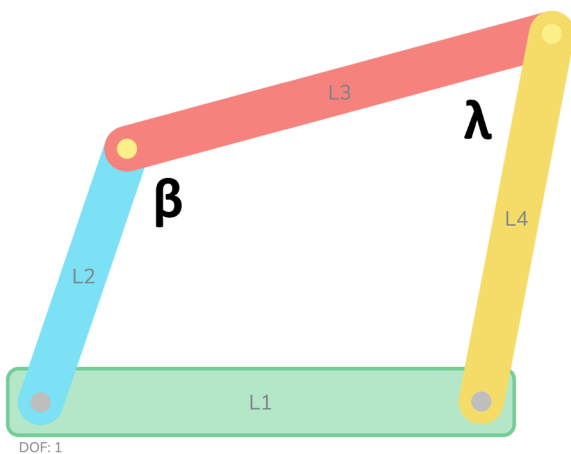

By inspection of this equation, you can see that mechanical advantage changes as the internal angles change (mechanism movement). Further, as the angle β goes towards zero, the mechanical advantage increase towards infinity (not possible with real materials but an artifact of mathematic kinematics). An angle of zero occurs when link 2 is in line with the ground link L1. This is the same position as when determining the minimum transmission angle. This is the reason that the minimum transmission angle is a good figure of merit for a mechanism. The ratio can be used to compute the ratio of

Mechanical advantage of a 4-bar linkage

input and output torque. For example, if a motor provides a known torque at a given rpm, the output or follower torque can also be determined.

Static Force Analysis

Static analysis is used by machine designers for mechanisms analysis in two general cases. First, to determine what is the required force needed to initiate the movement of a mechanisms that is intended to continuously move. Secondly, for some mechanisms the main objective of the mechanisms is to be stationary and apply some output force. Force analysis on the linkage mechanisms is based on the underlying assumption that each link is a rigid body. Force analysis requires a kinetic (relating to energy) instead of a kinematic approach. For position, velocity and acceleration, the linkage is described by link lengths, angles and time. For force analysis, we must include forces and mass. For static analysis, the governing equations for the linkage mechanism as a whole and each link is that the sum of all forces and the sum of moments are equal to zero, this is application of Newton's second law. Further, the forces one link puts on another or equal in magnitude, colinear, and opposite in directions on each other; Newton's third law.

Dynamic Force Analysis

Dynamic force analysis involves determining the centroid and mass moment of inertia of the linkage mechanism. These topics are covered extensively in dynamics textbooks in the area of rigid body kinetics. For simple problems, hand-based computation for single positions are reasonable. However, most machine design contexts, the designer is interested in the forces throughout the full range of mechanism motion. Most modern CAD software has built in motion dynamics analysis both from a kinetic and kinematic.

Velocity and Acceleration Analysis

Velocity and acceleration analysis for planar kinematic linkages is a method to determine the motion characteristics of the links and joints in a mechanism. The reasons to perform this analysis are to evaluate the performance, efficiency, and safety of the mechanism, as well as to design or optimize its parameters. For example, at what input rpm will the motor need to run to move the end of the mechanism a precise speed? Or what is the maximum acceleration of the link or a point on the link as it travels?

Both graphical and analytical solutions can be used for kinematic velocity and acceleration analysis. Graphical techniques are useful for determining velocity and acceleration at critical points, while analytical techniques are useful for solving for the whole range of motion.

Vector Loop Velocity and Acceleration Analysis

Recall that we can represent the position of each link as a vector and each vector can be described equivalently with Euler's number or sines and cosines. The value of using the Euler approach is that it is fairly trivial to take derivative of all the power of e , namely $\frac{d}{du}e^u = e^u$. Thus, a time derivative (rate of change of the angles) can be used to determine angular velocity of any in the mechanism. As with vector loop solutions for position analysis, the link lengths and at least one angular position must be known to solve for the others positions at any given time. Additionally, for velocity analysis, one angular velocity must be known. In the machine design context, this is often the known motor powering the mechanism or the desired velocity of the mechanism to find a suitable actuator. For acceleration analysis, all of the above constraints hold plus one angular acceleration must be known. However, a very common design mechanism design problem is to evaluate the acceleration of when the actuating motor is at a constant velocity (and thus angular acceleration is zero). In this situation, while the input angular acceleration is constant the other link angular accelerations are not necessarily zero.

Velocity Centers

The velocity center of a planar linkage mechanism is a point on the mechanism that has zero velocity at a given instant in time. It is also known as the instantaneous center of rotation (ICR). The velocity center can be used to analyze the motion of the mechanism and to design mechanisms for specific applications. ICR is a point at which it appears at that instant a linkage is rotating about. For a four-bar linkage, all of the revolute joints will be ICR. However, the number of instant centers in a linkage mechanism depends on the number of links in the mechanism. A linkage mechanism with n links will have $n(n-1)/2$ instant centers. For a four-bar linkage that means equals 6. So where are the other 2 centers? They can be found graphically by extending lines from the links and finding their intersection points of those lines. These points act like pivots at that point. Machine designers use the path that the instant centers travels through to evaluate the efficiency of the planar mechanism. At an critical points, the velocity centers are also useful for determining the velocity of any point on a linkage. If one velocity is known (for example the linear velocity of point A in the picture below based on known an input angular velocity and link length), then the magnitude of the velocity of point B can be readily determined by measure the distance between the ICR point and the point of interest. By equation, that is:

$$V_A = \omega_{ICR1} * Length_{ICR1toA}$$

and

$$V_B = \omega_{ICR1} * Length_{ICR2toB}$$

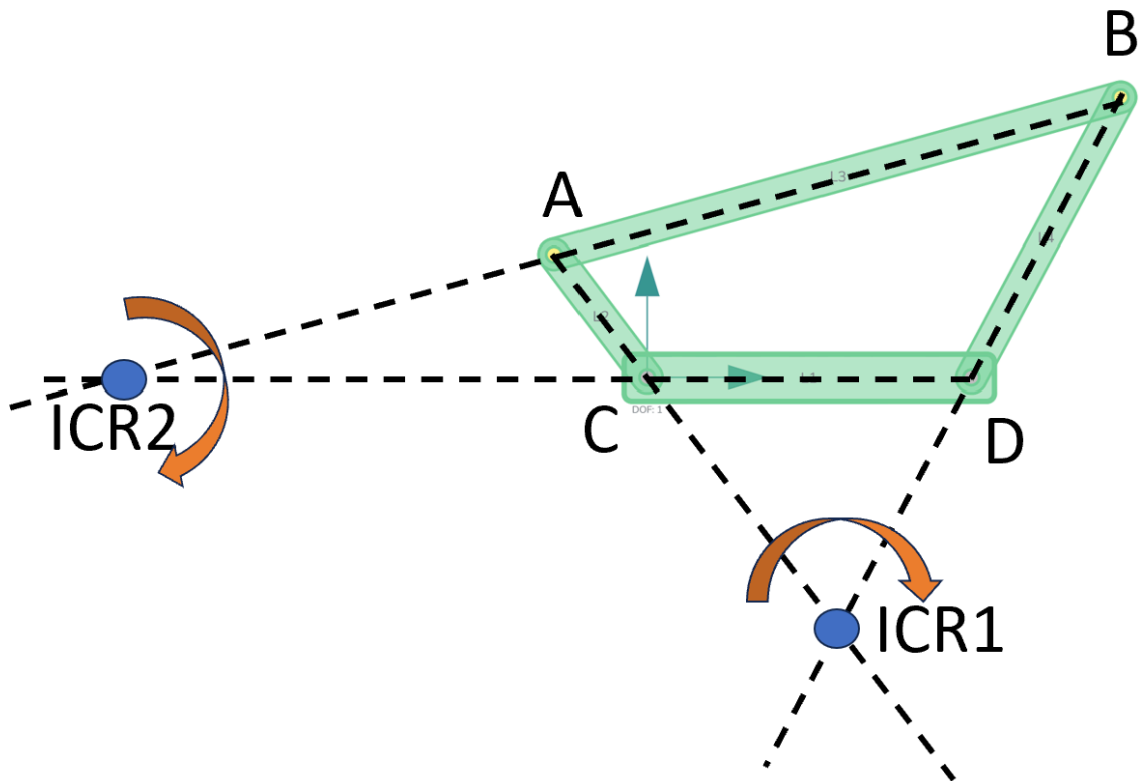

A 4-bar mechanisms has 6 instant centers.

Depending on how you prefer to learn material, you can follow along with a printed reading of analytical velocity and acceleration analysis here. Or...

Follow along as Professor Cummins explains how to do velocity and acceleration analysis on several examples.

Velocity Analysis



One or more interactive elements has been excluded from this version of the text. You can view them online here: <https://uark.pressbooks.pub/mechanicaldesign/?p=492#oembed-1>

Velocity Ratios



One or more interactive elements has been excluded from this version of the text. You can view them online here: <https://uark.pressbooks.pub/mechanicaldesign/?p=492#oembed-2>

Acceleration and Velocity Analysis



One or more interactive elements has been excluded from this version of the text. You can view them online here: <https://uark.pressbooks.pub/mechanicaldesign/?p=492#oembed-3>

CAM SYSTEMS AND CAM DESIGN

A cam and follower mechanism is a type of mechanical device that converts rotary motion into linear motion. It consists of a cam, which is a rotating disk or cylinder with an irregular shape, and a follower, which is a lever or other object that rides along the surface of the cam. The cam pushes or pulls the follower as it rotates, creating a specific motion pattern. Cam and follower mechanisms are widely used in various machines and systems, such as valves, engines, pumps, door locks, stamping machines, etc.

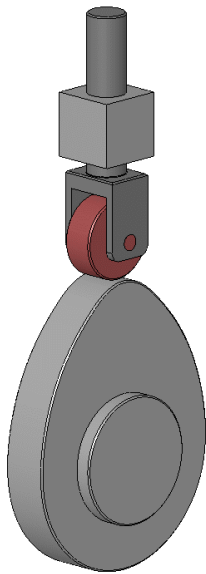

This illustrates simple cam follower action.



Cams are often used for precise timing applications since multiple cams can be used on the same shaft and will all have the exact same angular velocity.

Cams can have different shapes and profiles, depending on the desired output motion of the follower. Some of the common types of cams are disk or plate cams, wedge or flat cams, spiral cams, cylindrical or barrel cams, heart-shaped cams, translating cams, snail drop cams, conjugate cams, globoidal cams, and spherical cams. Each type of cam has its own advantages and disadvantages, and can

produce different types of follower motions, such as rise, dwell, return, or oscillation.

Followers can also have different shapes and designs, such as rollers, levers, slides, or knife edges. The shape of the follower affects the contact stress and friction between the cam and the follower. The follower can be constrained by gravity, springs, or positive drive. Gravity followers rely on the weight of the follower to maintain contact with the cam. Spring followers use a spring force to keep the follower in contact with the cam. Positive drive followers use a mechanical linkage or a groove to ensure positive engagement with the cam.

Follower Shape Specification

There are different types of cam follower shapes and their usages, advantages or disadvantages depend on the design and application of the cam mechanism. Some of the common types of cam follower shapes are:

Roller follower: A roller follower has a cylindrical shape that rolls on the cam surface. It reduces friction and wear between the cam and the follower, and provides smooth and continuous motion. However, it may have problems with alignment and stability, especially at high speeds or heavy loads.

Spherical follower: A spherical follower has a spherical shape that slides on the cam surface. It can accommodate angular misalignment and radial displacement between the cam and the follower, and can operate in any direction. However, it has more friction and wear than a roller follower, and may require lubrication and maintenance.

Knife-edge follower: A knife-edge follower has a sharp edge that slides on the cam surface. It is simple and inexpensive to manufacture, and can follow complex cam profiles. However, it has high friction and wear, and may cause noise and vibration.

Flat-faced follower: A flat-faced follower has a flat surface that slides on the cam surface. It can withstand high axial forces and loads, and can follow cams with abrupt changes in profile. However, it also has high friction and wear, and may require lubrication and maintenance.

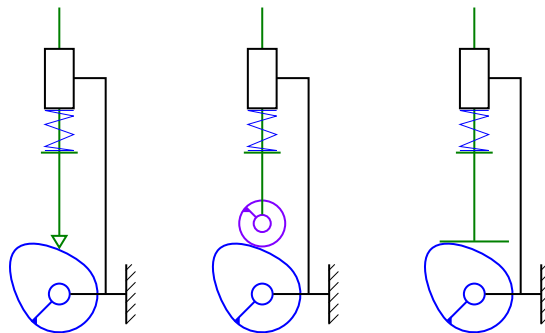

The type of follower affect the motion of the cam follower mechanisms. Shown here are point, roller and flat face (left to right) followers.

Cam Profile Specification

The profile of the cam is defined by specifying the extreme critical positions of the follower using position, velocity, acceleration, and jerk. These parameters are used to determine the shape and size of the cam, as well as the motion characteristics of the follower.

The position of the follower is the distance between its center and a reference point on the cam. The

position determines the displacement of the follower from its initial position. The velocity of the follower is the rate of change of its position with respect to time. The velocity determines the speed of the follower along its path. The acceleration of the follower is the rate of change of its velocity with respect to time. The acceleration determines the force required to move the follower. The jerk of the follower is the rate of change of its acceleration with respect to time. The jerk determines the smoothness or roughness of the follower motion.

The extreme critical positions of the follower are the points where its position reach the maximum or minimum values. . The cam profile can be obtained by connecting these points with suitable curves, such as circular arcs, polynomials, or splines.

Fundamental Law of Cam Design

The fundamental law of cam design is that the follower motion must be continuous and smooth, without any abrupt changes in velocity or acceleration. This is because any discontinuity in the follower motion would cause impact, vibration, noise, wear and tear, and reduced performance of the cam-follower system. To ensure smooth follower motion, the cam profile must be designed with certain geometric constraints, such as curvature, pressure angle, and contact stress. The cam profile can be generated by various methods, such as graphical, analytical, or numerical techniques, depending on the type and complexity of the follower motion desired.

The profile of the cam is divided into regions of rise, dwell and fall, which correspond to the portions of the cam rotation where the follower moves up, stays at the same level, or moves down. For example, a cam may have a rise region for 20 degrees of rotation, followed by a dwell region for 40 degrees, and then a fall region for 300 degrees. To ensure smooth and continuous motion of the follower, and to avoid violating the fundamental law of cam design, the position function that describes the rise or fall region must be either a polynomial function, a harmonic function, or a combination of both. A polynomial function is a function that involves only powers of the independent variable, such as x^2 or x^3 . A harmonic function is a function that involves trigonometric functions, such as $\sin(x)$ or $\cos(x)$. The potential combination of harmonics and polynomials enables a vast array of possible motions, speeds, and accelerations.

Cam Specification Example

Watch Professor Cummin's detailed cam-follower example below.



One or more interactive elements has been excluded from this version of the text. You can view them online here: <https://uark.pressbooks.pub/mechanicaldesign/?p=149#oembed-1>

Cam Specification in CAD

Below is a brief tutorial on defining the profile of a cam using the built in cam designer in the Solidworks toolbox. Other CADsoftware have similar features to support cam and follower design.



One or more interactive elements has been excluded from this version of the text. You can view them online here: <https://uark.pressbooks.pub/mechanicaldesign/?p=149#oembed-2>

GEARING SYSTEMS

Nomenclature

Gearing systems are mechanisms that use gears to transmit motion, force, or power from one shaft to another. Gears are wheels with teeth around their circumference that mesh with other gears to create a rotational relationship between their axes. Gears can be used to change the speed, torque, or direction of rotation of an output shaft, as well as to transfer motion to non-parallel axes.

There are different types of gears that have different shapes, sizes, and arrangements of teeth. Some common types of gears are:

- **Spur gears:** These are the simplest and most common type of gear. They have straight teeth that are parallel to the axis of rotation and mesh with other spur gears on parallel axes.
- **Helical gears:** These are similar to spur gears, but their teeth are cut at an angle to the axis of rotation. This makes them quieter and smoother than spur gears, but also creates an axial thrust force along the shaft.
- **Bevel gears:** These are gears that have teeth cut on a conical surface. They are used to transfer motion between intersecting axes, such as in a car differential.
- **Worm gears:** These are gears that have teeth shaped like a screw thread. They mesh with a worm wheel, which is a gear with helical teeth. Worm gears can reduce the speed and increase the torque of an output shaft by a large amount, but they also have high friction and wear.

Some important terms related to gearing systems are:

- **Pitch:** This is the distance between two adjacent teeth on a gear, measured along the pitch circle.
- **Pitch circle:** This is the imaginary circle that passes through the points where the teeth of two meshing gears contact each other. The pitch circles of two meshing gears are tangent to each other.
- **Module:** This is the ratio of the pitch to the number of teeth on a gear. It is a measure of the size of the teeth and determines how well two gears mesh together. The module of two meshing gears must be the same.
- **Gear ratio:** This is the ratio of the number of teeth on the output gear to the number of teeth on the input gear. It determines how much the speed and torque of the output shaft change compared to the input shaft. A gear ratio greater than one means that the output shaft rotates slower and has more torque than the input shaft. A gear ratio less than one means that the output shaft rotates faster and has less torque than the input shaft.
- **Gear train ratio:** This is the overall ratio of the speed and torque of the final output shaft to the initial input shaft in a system of multiple gears. It is equal to the product of the individual gear ratios of each pair of meshing gears in the system.
- **Pressure angle:** This is the angle between the line of action and the common normal at the point of contact

between two meshing teeth. The line of action is the line along which the force is transmitted between two meshing teeth. The common normal is the line perpendicular to both pitch circles at the point of contact. The pressure angle affects how much force is transmitted along the radial and axial directions of the shafts.

– Helical angle: This is the angle between the tooth face and an element of the pitch cylinder in a helical gear. It determines how much axial thrust force is generated by a helical gear pair.

Watch Professor Cummings provide a detailed example of each of these terms.



One or more interactive elements has been excluded from this version of the text. You can view them online here: <https://uark.pressbooks.pub/mechanicaldesign/?p=147#oembed-1>

Specifying a Gear Train

To design a gearing system, one needs to follow these steps:

1. Identify the input and output specifications, such as speed, torque, power, direction and type of motion.
2. Choose the type of gears that suit the application, such as spur, helical, bevel, worm, planetary, etc. Consider the advantages and disadvantages of each type, such as efficiency, noise, strength, size, etc..
3. Calculate the gear train ratio, which is the ratio of the number of teeth on the output gear to the number of teeth on the input gear. The gear ratio determines how much the speed or torque changes from the input to the output. Use the formula: $\text{gear ratio} = \text{output speed} / \text{input speed} = \text{input torque} / \text{output torque}$. If the gear train ratio is greater than about 1:10 you will likely need to use a compound gear train (multiple gear mates and shafts) to achieve the desired ratio.
4. For each gear mesh in the ratio, select: pitch (or module), number of teeth (according to ratio determined earlier), and material for the gears, based on the required load capacity, wear resistance, durability, cost, etc. Use standard tables or formulas to find the pitch diameter, module, pressure angle, face width, etc. of the gears. Note, most gear manufacturers have calculators on their websites for finding appropriate gears strengths.
5. Arrange the gears in a suitable configuration, such as parallel, intersecting or non-intersecting axes. Ensure that the gears mesh properly and have enough clearance and lubrication. Use sketches or CAD software to visualize and optimize the layout of the gearing system.
6. Test and evaluate the performance of the gearing system, using analytical methods or experimental methods. Check if the output speed and torque meet the specifications, and if there are any problems such as vibration, noise, overheating, etc. Make adjustments or improvements as needed.

For example, suppose we want to design a gearing system that converts a high-speed low-torque input from an electric motor to a low-speed high-torque output for a conveyor belt. We can use the following steps:

1. The input specifications are: speed = 1800 rpm (revolutions per minute), torque = 10 Nm (newton meters), power = 1885 W (watts), direction = clockwise, type of motion = rotary. The output specifications are: speed = 60 rpm, torque = 300 Nm, power = 1885 W (assuming 100% efficiency), direction = clockwise, type of motion = rotary.
2. We can choose spur gears for this application, because they are simple, cheap and efficient. Spur gears have parallel axes and straight teeth that mesh along a line.
3. We can calculate the gear ratio using the formula: gear ratio = output speed / input speed = input torque / output torque. Plugging in the values, we get: gear ratio = 60 / 1800 = 10 / 300 = 0.0333. This means that for every revolution of the input gear, the output gear makes 0.0333 revolutions. Note – This should be accomplished using a compound gear set with several gear mates not one. However, for the purposes of explanation we will consider a poor design with just one mate.
4. We can select standard spur gears with a module of 2 mm (millimeters) and a pressure angle of 20 degrees. The module is the ratio of the pitch diameter to the number of teeth, and it determines how big or small the gears are. The pressure angle is the angle between the line of action and the tangent to the pitch circle, and it affects how much force is transmitted between the gears. Using standard tables or formulas, we can find that the pitch diameter of the input gear is 40 mm and it has 20 teeth. The pitch diameter of the output gear is 1200 mm and it has 600 teeth. The face width of both gears is 20 mm. Here, you can see why a compound gear is needed. For example, had we split the gear train into two meshes of 1:5 and 1:6 we could have a lot smaller total gear system. Start with gear one with 20 teeth and a module of 2 mm results in a diameter of 40 mm (20×2). This meshes with a gear of 100 teeth (1:5 ratio) and a pitch diameter of 200 mm. This second gear can be on the same shaft as the third gear which we can be the same size as gear 1 (20 teeth, 40mm diameter). Finally, this third gear meshes with a gear of 120 teeth and 240 mm diameter. The compound arrangement thus results in a total width of the gear train being much smaller than a single mesh.
5. We can arrange the gears in a simple configuration with parallel axes and one pair of meshing spur gears. The center distance between the axes is half of the sum of the pitch diameters: center distance = $(40 + 1200) / 2 = 620$ mm. We can use a sketch or CAD software to draw and optimize the layout of the gearing system.
6. We can test and evaluate the performance of the gearing system using analytical methods or experimental methods. We can use formulas or software to calculate the output speed and torque from the input speed and torque and compare them with the specifications. We can also measure them using instruments such as tachometers and dynamometers. We can check if there are any problems such as vibration, noise, overheating, etc., and make adjustments or improvements as needed.

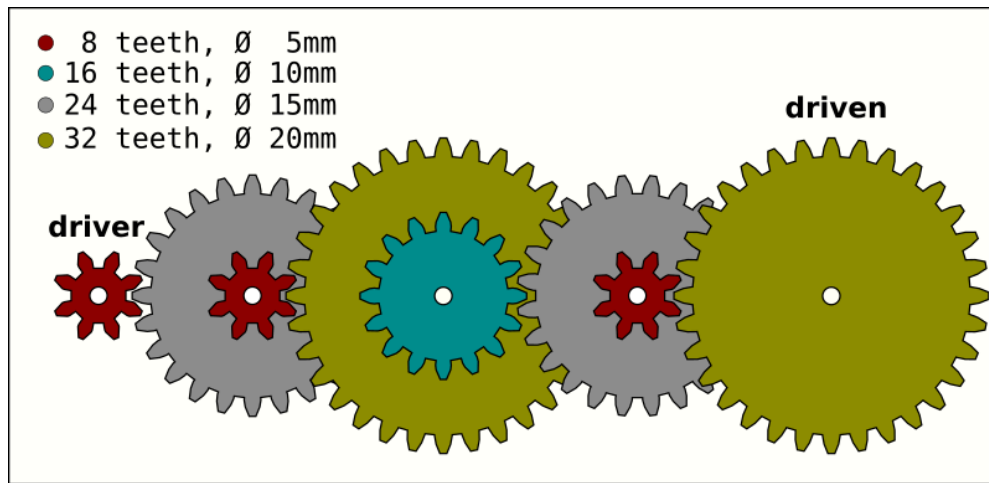

Generic example of a compound gear train.

Determining a Gear Train Ratio

Finding the correct ratio for each mesh in a gear train requires deciding which type of gear train to use.



One or more interactive elements has been excluded from this version of the text. You can view them online here: <https://uark.pressbooks.pub/mechanicaldesign/?p=147#oembed-2>

Finding Gears from a Supplier Catalog

This is a walk through of a particular gear catalog. Most suppliers have similar websites and tools to aid in gear selection.



One or more interactive elements has been excluded from this version of the text. You can view them online here: <https://uark.pressbooks.pub/mechanicaldesign/?p=147#oembed-3>

PULLEYS AND BELTS AND CHAIN AND SPROCKET SYSTEMS

Pulleys and belts and sprocket and chain systems are common methods of power transmission in machines. They are used to transfer rotational motion and torque from one shaft to another shaft, usually with different speeds or diameters.

Pulleys and belts are composed of two circular discs (pulleys) mounted on parallel shafts and connected by a flexible band (belt) that runs over them. The pulleys can have the same or different diameters, which determines the speed ratio between the shafts. The belt can be made of various materials, such as rubber, leather, fabric or metal, depending on the application. The belt can also have different profiles, such as flat, V-shaped, round or toothed, to improve the grip and reduce slippage.

The main advantages of pulleys and belts are that they are **quiet, efficient, low-cost, and easy to install**. They also allow for some flexibility in the layout of the shafts, as they can accommodate small misalignments and distances. Some disadvantages are that they are ****less durable**** than chains or gears, they ****require tensioning**** to prevent slipping or sagging, they ****can stretch or wear out**** over time, and they ****cannot transmit very high torques**** or loads.

Some examples of pulleys and belts are:

- Timing belts: These are toothed belts that mesh with toothed pulleys to ensure precise synchronization of the shafts. They are used in applications such as car engines, printers and robotics.
- V-belts: These are V-shaped belts that fit into V-shaped grooves on the pulleys. They are used in applications such as fans, pumps and compressors.
- Flat belts: These are flat belts that run on flat or crowned pulleys. They are used in applications such as conveyor belts, sewing machines and agricultural machinery.

Read the specification guide from Oris Industrial [Here](#).

Spend a few minutes exploring the part catalog from Automation Direct.

Sprockets and chains are composed of two toothed wheels (sprockets) mounted on parallel shafts and

connected by a series of links (chain) that mesh with them. The sprockets can have the same or different numbers of teeth, which determines the speed ratio between the shafts. The chain can be made of metal or plastic, depending on the application. The chain can also have different types, such as roller chain, bush chain or silent chain, to improve the performance and reduce noise.

The main advantages of sprockets and chains are that they are **robust**, **durable** and **capable of transmitting high torques** and loads. They also have a **positive engagement** between the sprockets and the chain, which prevents slipping or skipping. Some disadvantages are that they are **noisy**, **require lubrication** to prevent wear and corrosion, they **can stretch or break** under excessive stress, and they **have limited flexibility** in the layout of the shafts.

Some examples of sprockets and chains are:

- Bicycle chain: This is a roller chain that connects the pedals to the rear wheel of a bicycle. It allows the rider to change the speed ratio by shifting gears on the sprockets.
- Motorcycle chain: This is a roller chain that connects the engine to the rear wheel of a motorcycle. It allows the rider to change the speed ratio by shifting gears on the sprockets.
- Conveyor chain: This is a bush chain that connects a series of rollers or plates on a conveyor belt. It allows the movement of materials or products along a production line.

The design of pulleys and belts and sprocket and chain systems depends on several factors, such as:

- The required speed ratio between the shafts
- The required torque or power transmission
- The available space and distance between the shafts
- The expected load and service life
- The environmental conditions and maintenance requirements

Some general principles for designing these systems are:

- Choose the appropriate type and size of belt or chain for the application
- Choose the appropriate number and diameter of pulleys or sprockets for the desired speed ratio
- Ensure adequate tensioning or slackness of the belt or chain to prevent slipping or sagging
- Ensure adequate alignment and lubrication of the pulleys or sprockets to prevent wear and friction
- Ensure adequate safety factors and clearances to prevent failure or interference

Take some time and explore Martin Sprocket's guide to sprocket design and specification.

WRAP UP - ASSEMBLIES FOR MOTION AND POWER

The goal of this chapter to help you identify how to achieve motion in your mechanical product or machine. The most common motion enabling assemblies are:

- Linkage mechanisms: rigid bodies connected by joints that transmit force and motion. Linkages can be used for lots of different types of motion, such as linear, rotary, oscillating, and complex.
- Linkage synthesis and motion analysis: methods for finding the dimensions and positions of linkages that satisfy a given motion requirement. There are both graphical and analytical techniques for linkage synthesis and motion analysis.
- Cam and follower assemblies: devices that convert rotary motion into complex or irregular motion. You design the cam profile and select a follower type for the specific application.
- Gearing assemblies: sets of gears that transmit motion and torque between shafts. Choose gear types, sizes, ratios, and arrangements for various purposes, such as speed reduction, power transmission, and direction change.
- Belt and sprocket assemblies: systems that use belts or chains to transmit motion and torque between pulleys or sprockets. Select belt or chain types, sizes, lengths, tensions, and alignments for different scenarios, such as smooth or jerky motion, constant or variable speed, and high or low load.

Section Questions



An interactive H5P element has been excluded from this version of the text. You can view it online here:

<https://uark.pressbooks.pub/mechanicaldesign/?p=307#h5p-10>

PART IX

PRODUCT DESIGN PROTOTYPING

Learning Objectives

Developing prototypes is an essential part of the product design process. After this part, readers should be able to:

- Describe the purpose of different types of prototypes.
- Define a strategy for developing prototypes throughout the design process.
- Understand and utilize best practices of common prototyping technologies.

Prototyping is an essential part of the mechanical product design process, as it allows designers to test and evaluate their ideas, communicate with stakeholders, and refine their solutions. In this chapter, we will introduce the concept of prototyping and its objectives, such as feasibility, usability, and desirability. We will also explore the different types of prototypes, such as sketches, mock-ups, models, and functional prototypes, and how they can be used at different stages of the design process, such as ideation, evaluation, and validation. Moreover, we will discuss the strategies for developing effective prototypes, such as iterative prototyping, parallel prototyping, and user-centered prototyping. Finally, we will present the technologies and best practices for developing prototypes, such as 3D printing, laser cutting, CNC machining, and rapid prototyping methods.

TYPES OF PROTOTYPES AND PROTOTYPING STRATEGY

Justifying Prototype Development

Prototyping is not a trivial task and it requires careful planning and justification. Depending on the type of prototype, the expense to develop can be very high and therefore needs a good justification. The type of prototype developed depends on the overall objective of the project and the stage of the design process. Some possible justifications for developing a prototype are:

1. **Validating a concept, physical phenomenon, or user experience:** A prototype can be used to test whether the underlying idea or principle of the solution is sound and viable. For example, a prototype can be used to verify if a certain material can withstand a certain stress level, or if a certain interface can provide a satisfactory user experience.
2. **Securing feedback and buy in from stakeholders:** A prototype can be used to communicate the vision and value proposition of the solution to the potential users, customers, investors, or partners. A prototype can help elicit feedback and suggestions from the stakeholders, as well as generate interest and support for the project.
3. **Exploration of design parameters:** A prototype can be used to explore different aspects of the solution, such as the size, shape, color, functionality, performance, cost, etc. A prototype can help identify the optimal design parameters that can meet the requirements and constraints of the project.

Types of Prototypes and Uses

A prototype is a representation of a design that serves a specific purpose: to test a hypothesis or assumption about the design problem. Depending on the nature of the question that needs to be answered, different types of prototypes can be more or less suitable. In this section, we will discuss how to choose the right type of prototype for each stage of the design process, and what are the advantages and limitations of each type.

One way to classify prototypes is by their format, or how they represent the design idea in a tangible or intangible way. There are three main formats of prototypes:

1. **Physical prototypes:** These are real objects that mimic the appearance, functionality, interaction, and

fabrication aspects of the design. Physical prototypes can be used to evaluate how the design fits in the context of use, how users interact with it, how it performs its intended functions, and how it can be manufactured and assembled.

2. **Sketches, layouts, and diagrams:** These are two-dimensional drawings that illustrate the design concept from different perspectives. Sketches, layouts, and diagrams can be used to communicate the overall idea, the system architecture, the information or material flow, and the comparison between different alternatives.
3. **Digital and computational models:** These are mathematical or computer-based representations of the design that capture its behavior, performance, or optimization. Digital and computational models can be used to explore the design space, to analyze the trade-offs between different parameters, to simulate the outcomes under different scenarios, and to optimize the design for specific criteria.

Additionally, we can characterize prototypes by their primary function or type of hypothesis they can address. These are also listed generally in order of stages in the design processes. Recall that design can often be iterative in nature.

1. **Proof-of-concept prototype:** This type of prototype is used to test the feasibility of a concept or idea. It is usually a simple model that demonstrates the basic functionality of the product.
2. **Form study prototype:** This type of prototype is used to explore the physical appearance and aesthetics of the product. It is usually a non-functional model that helps designers to visualize the product.
3. **User experience prototype:** This type of prototype is used to test the usability and user experience of the product. It is usually a functional model that simulates the interaction between the user and the product.
4. **Functional prototype:** This type of prototype is used to test the functionality of the product. It is usually a working model that demonstrates the key features and performance of the product.
5. **Pre-production prototypes:** These are the final prototypes that are made with the same materials, processes, and specifications as the mass-produced product. They can be used to validate the manufacturing and assembly plan. They can also be used to verify the quality and consistency of the product, and to prepare for the transition to production. They may also be used for marketing or regulatory purposes.

Timing and Development Strategy

The three primary drivers of a prototype development strategy are the flexibility or rigidity of:

- **Prototype development cost:** High-cost prototypes tend to result in lower number of prototypes and prototypes that address only specific aspects of the design. For example, testing prototyping specific

engine types rather than the entire aircraft.

- **Time to market requirements:** If getting to market first is the main driver (such as new technology), then spending time refining prototypes is less valuable.
- **Product performance requirements:** If the market for this product already exists, then meeting performance requirements is critical to achieve sales goals. Therefore, spending extra time refining the design through prototypes is justified.

Further, prototypes can be generated sequentially to develop a single concept or in parallel to evaluate multiple concepts concurrently. If we put together these concepts of rigidity and flexibility on the above three constraints and sequential or parallel approach, then we can form the following design recommendations depending on context. 1 represents very rigid while 0 represents completely flexible. A realistic strategy will be somewhere between.

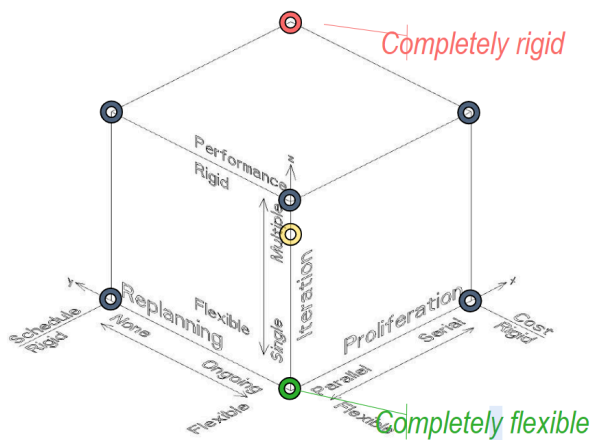

	Given these conditions:			Do the following:
	Cost Flexibility	Schedule Flexibility	Performance Flexibility	Prototype Partitioning Strategy
Cost and schedule flexible	0	0	0	No iteration of multiple investigated efforts
	0	0	1	Iteration(s) of multiple investigated efforts
Cost rigid	1	0	0	No iteration of a single investigated effort
	1	0	1	Iteration(s) of a single investigated effort
Schedule Rigid	0	1	0	No iteration of multiple intuitive efforts
	0	1	1	Iteration(s) of multiple intuitive efforts
Cost and Schedule rigid	1	1	0	No iteration of a single intuitive effort
	1	1	1	Iteration(s) of a single intuitive effort

Design strategy based on flexibility and iterations.

A strategy will be based on flexibility of cost, time and performance.

PROTOTYPING METHODS AND TECHNOLOGIES

Cost Minimization and Value Maximization

The main goal of building physical prototypes is to find the optimal trade-off between meeting the prototype's objectives and minimizing its cost and maximizing its informational value. In other words, we want to create the most affordable prototype that can give us useful feedback on the design with a reasonable degree of uncertainty. Depending on the stage of the design process, different types of prototypes may be more suitable. For example, a simple proof-of-concept prototype can be made by hand from materials like cardboard. This type of prototype can help us evaluate the size, layout of components, and general idea of the design, but it cannot tell us much about the manufacturing process or the functionality. On the other hand, a scaled functional prototype of an aircraft turbine engine can provide a lot of information about the performance, but it is very expensive to make. It would not make sense to use this kind of prototype to answer questions about the size or arrangement of components. Therefore, we need to first identify the purpose of the prototype and then choose the technology or method that will produce the prototype with the lowest cost and highest value. We also need to consider the additional costs of secondary processes, such as sanding and removing support material, and assembly that may affect the prototype development.

Rough Mock-Ups

Proof-of-concept prototypes are often built in the early design stage to explore and compare different concept solutions. Since the main goal is communication of concept and limited functionality, these types of prototypes are often made with craft materials. Cardboard, hardboard, wood, plastic and metal building blocks, and clay are common materials.

Best Practices for Mock-Ups

- Focus on communicating the key concept. If the goal is to demonstrate how the product would move, focus on the movement not necessarily the size or color.
- Be careful about unintentionally inheriting design fixation based on the material. For example, using pre-made toy building blocks may lead to inadvertent design for simple rectangular structural elements.

- Give the time needed for building an effective model. Crafting can be a longer than expected process. Invest additional time and resources if using this prototype for securing stakeholder buy-in.

See many more practical tips for mock-ups and other types of prototypes here:



One or more interactive elements has been excluded from this version of the text. You can view them online here: <https://uark.pressbooks.pub/mechanicaldesign/?p=528#oembed-1>

Additive Manufacturing Methods

Additive manufacturing (AM) is a process of creating three-dimensional objects by adding material layer by layer, following a digital model. AM can be used for both full-scale production and prototype development, depending on the design, material, and application. AM offers several advantages for prototyping, such as speed, flexibility, and cost-effectiveness.

Some of the common technologies for prototype manufacturing using AM are:

- Fused deposition modeling (FDM): This technology uses a heated nozzle to extrude thermoplastic filaments onto a build platform, forming the desired shape. FDM is suitable for prototyping functional parts that require strength and durability.
- Stereolithography (SLA): This technology uses a laser beam to selectively cure liquid resin into solid layers, creating high-resolution and smooth-surfaced models. SLA is suitable for prototyping complex geometries and fine details that require accuracy and aesthetics.
- Selective laser sintering (SLS): This technology uses a laser beam to fuse powdered material, such as nylon or metal, into solid layers, forming dense and robust parts. SLS is suitable for prototyping parts that require high mechanical performance and thermal resistance.



One or more interactive elements has been excluded from this version of the text. You can view them online here: <https://uark.pressbooks.pub/mechanicaldesign/?p=528#oembed-2>

Best Practice for Prototype Development with AM

- Consolidate multi-part assemblies into single parts whenever possible. This can reduce the number of interfaces, joints, fasteners, and supports needed, and improve the structural integrity, functionality, and aesthetics of the prototype. However, this also requires careful consideration of the design constraints, such as printability, accessibility, and assembly/ disassembly.
- Use the right design software that can handle the complexity and diversity of AM processes and materials. Traditional CAD software may not be sufficient for designing parts that exploit the full potential of AM, such as lattice structures, organic shapes, or multi-materials. Therefore, it is advisable to use software that can support AM-specific features, such as topology optimization, generative design, or slicing. Some CAD tools can simulate the manufacturing process, helping to identify potential issues such as thermal stress concentrations.
- Pay attention to the printing orientation of the part. The printing orientation can affect the dimensional accuracy, surface roughness, layer visibility, support structures, and mechanical properties of the part. For example, printing a part horizontally can minimize the need for supports and reduce the layer visibility, but it can also increase the surface roughness and decrease the strength along the layer direction. Therefore, it is important to choose the optimal printing orientation that balances these factors according to the design requirements.
- design based on the printing resolution of the chosen AM technology. The printing resolution determines how fine or coarse the layers are, and how well the part matches the digital model. Different AM technologies have different printing resolutions, depending on the type and size of the material used. For example, fused deposition modeling (FDM) uses thermoplastic filaments that are extruded through a nozzle, resulting in relatively low resolution and high layer visibility. Stereolithography (SLA) uses liquid photopolymer resin that is cured by a laser beam, resulting in relatively high resolution and smooth surface finish. Selective laser sintering (SLS) uses powder material that is fused by a laser beam, resulting in moderate resolution and rough surface texture. Therefore, it is important to design the part according to the capabilities and limitations of the chosen AM technology.

Subtractive Manufacturing Methods

Subtractive manufacturing is a process that removes material from a solid piece of raw material to create a desired shape or form. Subtractive methods are widely used in traditional or mass manufacturing, such as machining, cutting, drilling, and carving. However, some subtractive technologies are also suitable for rapid prototyping.

Laser cutting uses a high-powered beam of light to cut through various materials, such as metal, wood, plastic, and paper. Laser cutting can produce precise and complex shapes with smooth edges and fine details.

Laser cutting is also fast and efficient, as it can cut multiple layers of material at once. A similar approach is water jet cutting.

Another subtractive method that can be used for rapid prototyping is desktop milling, drilling, and turning. These are small-scale versions of the machining processes that use rotating tools to remove material from a workpiece. Desktop milling, drilling, and turning can be used for small batch production of prototypes that require high accuracy and quality. These processes can work with different materials, such as metal, wood, plastic, and composite.

BUILDING AND TESTING PROTOTYPES

Guideline for Making Prototypes

The most important guideline when it comes to making prototypes is to only make what is needed. That is, the time and effort to construct a prototype should be justified by the questions it can answer. For example, if you need to know how heavy something will be, that can be readily answered with any CAD software by specifying the material property. The question “does this feel too heavy” cannot be answered in CAD. Always build just enough to accurately address the current unknowns and move the design process forward. This concept of forward progress can also help you identify what needs to be modeled. The more the prototype moves the design process forward the more value provided and better justified is the effort in building it.



One or more interactive elements has been excluded from this version of the text. You can view them online here: <https://uark.pressbooks.pub/mechanicaldesign/?p=530#oembed-1>

Testing Prototypes

The value of a prototype in moving the design process forward is also limited by the approach used in testing that prototype to learn more information. Product usability tests are limited by the audience that test. A fairly common mistake is to rely on engineers and others who are familiar with the product and its particular evolution to test usability in the early design stages. It may make sense from a logistical point of view, but it is nearly impossible to quantify all of the biases and preconceived knowledge that we bring to a project. Usability should be tested with actual potential users of the product. This is a best practice for industrial prototypes that demonstrate the look, feel, and interface of a product. Some prototyping is focused on functional testing. That is, addressing unknown interactions and underlying physics to evaluate if a product or concept can achieve the desired function to the desired quality of performance. For these types of prototypes, users are generally not needed. Rather, a robust experimental set up.

Your testing goals may produce qualitative data, quantitative data or both. **Qualitative data** is information that cannot be measured or quantified, but can provide insights into the user’s preferences, opinions, feelings, and behaviors. An example of qualitative data collected in physical product prototype testing is the feedback

from users who interact with the prototype and share their thoughts and impressions. This feedback can help the product team understand what aspects of the prototype are appealing, confusing, satisfying, or frustrating to the users, and how they can improve the design and functionality of the product.

Quantitative data is numerical information that can be measured or counted. In physical product prototype testing, quantitative data can help evaluate the performance, usability and functionality of the product. For example, a prototype of a new smartphone can be tested by measuring its battery life, screen resolution, processing speed, memory capacity, etc. These are quantitative data that can indicate how well the product meets the design specifications and user expectations.

It is important to note that both qualitative data and quantitative data require a rigorous collection approach. Prototype testing is a scientific process, and the scientific method must be applied.

As you have likely been exposed to the scientific method in prior courses; the scientific method is a systematic process of inquiry that involves making observations, formulating hypotheses, designing experiments, collecting data, analyzing results, and drawing conclusions. For example, a designer who wants to test a new chair prototype might observe how people sit on different types of chairs, formulate a hypothesis about what makes a chair comfortable and ergonomic, design an experiment to measure the comfort and posture of the users, collect data from the experiment using sensors and surveys, analyze the data using statistical methods, and draw conclusions about the strengths and weaknesses of the prototype.

Testing of prototypes should always follow a well-structured experimental plan. This is developed using the Design of Experiments (DOE) methodology.



One or more interactive elements has been excluded from this version of the text. You can view them online here: <https://uark.pressbooks.pub/mechanicaldesign/?p=530#oembed-2>

WRAP-UP - PROTOTYPING PRODUCT CONCEPTS

Prototyping is an essential stage in the mechanical product design process, as it allows designers to test and evaluate their ideas, identify and solve problems, and communicate their concepts to stakeholders. Prototyping strategy refers to the plan and methods for creating and using prototypes throughout the design cycle. Prototyping generating technology refers to the tools and techniques for producing physical or virtual models of the product. One of the most widely used prototyping generating technologies is additive manufacturing (AM), which is a process of creating objects by depositing layers of material on top of each other. AM offers many advantages for prototyping, such as speed, flexibility, customization, and complexity. AM can also enable new design possibilities that are not feasible with traditional manufacturing methods.

Section Questions:



An interactive H5P element has been excluded from this version of the text. You can view it online here:

<https://uark.pressbooks.pub/mechanicaldesign/?p=534#h5p-11>

PART X

DESIGN FOR MANUFACTURING AND ASSEMBLY PRINCIPLES AND METHODS

Learning Objectives

In this section we will discuss the general principles of design for manufacturability and design for assembly. Also critical to achieving quality functional products is proper dimensions and tolerancing of parts. Therefore, this section also covers basics of geometric dimensions and tolerancing as well as the specification of fits. In short, how to design parts so that they can be manufactured and assembled to work well with an acceptable level of quality. After completing this section, reader should be able to:

- Define what DFMA is and why it is important for the design process.
- Apply DFMA principles and practices in different domains and contexts.
- Describe methods and tools are available for DFMA analysis and evaluation.
- Apply principles to measure and improve the performance of a product or system using DFMA metrics and criteria.
- Understand and use standard GD&T symbols in part drawings.
- Specify a desired size and tolerance for a fit using standard tables.

Design for manufacturability and assembly (DFMA) is a set of principles and practices that aim to optimize the design of a product or system for its efficient and effective production and integration. DFMA is an important part of the design process because it can reduce the cost, time, complexity, and environmental impact of manufacturing and assembling a product or system. DFMA can also improve the quality, reliability, performance, and customer satisfaction of the final product or system. In this chapter, we will introduce the concepts and benefits of DFMA, as well as the methods and tools for applying it in different domains and contexts.

Follow along with Professor Cummings' introductory lecture to understand the context of DFMA.



One or more interactive elements has been excluded from this version of the text. You can view them online here: <https://uark.pressbooks.pub/mechanicaldesign/?p=167#oembed-1>

DESIGN FOR MANUFACTURING PRINCIPLES

Design for manufacturability (DFM) is a set of engineering principles and practices that aim to optimize the design of a product or a component for its manufacturing process. DFM helps to ensure that the product can be manufactured efficiently, cost-effectively, and with high quality. DFM can be applied at different stages of the product development cycle, from conceptual design to detailed design, prototyping, testing, and production.

Effective DFM is critical for companies to reduce overall cost and meet quality goals.



One or more interactive elements has been excluded from this version of the text. You can view them online here: <https://uark.pressbooks.pub/mechanicaldesign/?p=536#oembed-1>

The main goals of DFM are:

- **Improve manufacturing feasibility:** DFM helps to avoid or minimize design features that are difficult, expensive, or impossible to manufacture, such as complex shapes, tight tolerances, excessive parts, or incompatible materials. DFM also helps to select the most appropriate manufacturing process and equipment for the product, considering factors such as production volume, quality requirements, lead time, and environmental impact. By improving manufacturing feasibility, DFM can reduce the risk of defects, delays, rework, or scrap.
- **Reduce overall cost of manufacturing:** DFM helps to reduce the cost of manufacturing by eliminating or simplifying design features that increase the material, labor, tooling, or overhead costs. DFM also helps to optimize the use of resources and materials, such as reducing waste, energy consumption, or inventory. By reducing the cost of manufacturing, DFM can increase the profitability and competitiveness of the product.
- **Improve the quality of the product:** DFM helps to improve the quality of the product by ensuring

that the design meets the functional and performance specifications and expectations of the customer. DFM also helps to enhance the reliability, durability, safety, and usability of the product by avoiding or minimizing design features that can cause failures, errors, or dissatisfaction. By improving the quality of the product, DFM can increase customer satisfaction and loyalty.

Many of the principles for DFM will be process specific. In later chapters we will discuss specific traditional manufacturing methods and the “design for ...” concerns for each method. However, there are some general principles that are applicable to most if not all manufacturing methods:

- Use common materials that are known to be effective for the application, are readily available, and compatible with the chosen manufacturing process and equipment.
- Minimize part size and weight by removing excess material or using lighter materials.
- Simplify part geometry by avoiding complex shapes or features that require special tools or processes.
- Use generous tolerances and clearances that are consistent with the functional requirements and quality standards of the product.
- Design for ease of inspection and testing by providing adequate access and visibility to critical features and functions.

DESIGN FOR ASSEMBLY PRINCIPLES

Primary Objective of DFA

Design for assembly (DFA) is a product design process that aims to optimize the product structure and the assembly process by reducing the number of components and minimizing the number of assembly operations required. The main objectives of DFA are to lower the assembly costs, improve the product quality and reliability, and shorten the time to market. DFA involves analyzing each part in an assembly and determining whether it is necessary for the product functionality, aesthetics, or maintenance. If a part does not meet any of these criteria, it should be eliminated or combined with another part. DFA also considers the ease of grasping, orienting, and inserting each part during the assembly process, and provides numerical evaluation methods to estimate the assembly time and cost for manual or automatic assembly.

Principles of DFA

DFA is a set of best practices and tools to support those best practices. While not objective physical laws that must always be followed, in general, time spent implementing these practices and analysis of the assembly process can reduce those associated costs.

Minimizing part count

This is the first and most important and effective best practice of DFA. This principle involves reducing the number of components in a product, which simplifies the product structure and the assembly process. Fewer parts also mean less material, inventory, handling, tooling and maintenance costs. For example, a plastic bottle cap can be designed as a single piece instead of having a separate seal and cap.

One of the best ways to implement this principle is to perform an analysis of **part count efficiency**. This is a process that involves defining essential and non-essential parts and calculating a part count efficiency as the ratio of essential over total parts.

Essential parts are those that are necessary for the function, performance or appearance of the product or system. **Non-essential parts** are those that can be eliminated, integrated or replaced without compromising the function, performance or appearance of the product or system. To identify essential and non-essential parts use a checklist of criteria:

- Does the part move relative to other parts?
- Does the part have to be made of a different material than other parts?
- Does the part have to be separated from other parts for maintenance or repair?
- Does the part affect the aesthetics or ergonomics of the product or system?
- Does the part have a specific regulatory or safety requirement?

Based on these criteria, classify each part as essential or non-essential and then count the number of each type. The **part count efficiency** is then calculated by dividing the number of essential parts by the total number of parts. The higher the part count efficiency, the more optimized the product or system is in terms of minimizing part count. Practically speaking, no real products have *only* essential parts based on the above criteria. Aim for efficiencies greater than 80%.

Modularize

This principle involves designing a product as a collection of independent modules that can be easily assembled, disassembled, replaced or upgraded. Modular design allows for parallel assembly, mass customization, easier testing and repair. For example, a laptop computer can be designed as a modular product with separate modules for the screen, keyboard, battery, hard drive, etc.

Built-in fasteners or Designing Self-Fastening Features

This principle involves integrating fasteners into the parts that need to be joined, eliminating the need for separate fasteners such as screws, nuts, bolts, washers, etc. Built-in fasteners reduce part count, assembly time and tooling costs. For example, a plastic case can be designed with snap-fits or tabs that lock into place without requiring any screws.

Use Symmetry Wisely

This principle involves designing parts that are symmetrical or have rotational symmetry, so that they can be oriented in any way during assembly. Symmetrical parts reduce the need for reorientation, alignment and orientation verification. For example, a cylindrical battery can be inserted into a battery holder in any direction. Anti symmetry can also be used. If it is important that parts mate in only one direction, add asymmetric features that make it impossible to miss-assemble. This is discussed more in the following principle.

Mistake-proofing (see Poka-Yoke)

This principle involves designing parts and assembly processes that prevent or detect errors and defects. Mistake-proofing can be achieved by using features such as color coding, shape coding, keying, interlocking, etc. that ensure correct part selection, orientation and insertion. For example, a USB connector can be designed with a trapezoidal shape that prevents incorrect insertion.

Use Commercially Available Standardized Parts (COTS)

This principle involves using parts that are readily available in the market and conform to industry standards, instead of customizing or making them in-house. Standardized parts reduce design time, material costs, inventory costs and compatibility issues. For example, a circuit board can be designed with standard components such as resistors, capacitors, transistors, etc.

Keep Tolerances Realistic

This principle involves specifying tolerances that are appropriate for the function and quality of the product, without being too tight or too loose. Tolerances affect the fit, function and performance of the parts and the product. Too tight tolerances increase manufacturing costs and defects, while too loose tolerances reduce product quality and reliability. For example, a shaft can be designed with a tolerance of ± 0.01 mm if it needs to fit into a bearing with minimal clearance.

Assembly Process Considerations

This principle involves designing parts and products that are easy to handle, manipulate and join during assembly. Assembly process considerations include minimizing handling steps, avoiding sharp edges or burrs that can injure workers or damage parts, using self-aligning or self-locating features that reduce alignment errors, using easy-to-access fasteners that reduce tooling costs and assembly time, etc. For example, a furniture piece can be designed with pre-drilled holes and screws that are easy to access and tighten.

See below for examples of implementing these

principles:



One or more interactive elements has been excluded from this version of the text. You can view them online here: <https://uark.pressbooks.pub/mechanicaldesign/?p=538#oembed-1>

INTRODUCTION TO GEOMETRIC DIMENSIONS AND TOLERANCES

GD&T Definitions and Basics

Geometric Dimensioning and Tolerancing (GD&T) is a system for defining and communicating engineering tolerances via a symbolic language on engineering drawings and computer-generated 3D models that describes a physical object's nominal geometry and the permissible variation thereof. GD&T is used to communicate the design intent of a part, focusing on the function of the part rather than its exact dimensions. GD&T allows the designer to specify larger tolerances for less important features, resulting in a part that is easier and cheaper to produce. GD&T is based on communication using standard symbols to define features and their allowable tolerances. There are several standards that describe the symbols and rules of GD&T, such as the American Society of Mechanical Engineers (ASME) Y14.5 Standard and the International Organization for Standardization (ISO) Geometrical Product Specifications (GPS). These standards provide a common language for engineers and manufacturers to ensure that the parts meet the functional requirements of the design.



One or more interactive elements has been excluded from this version of the text. You can view them online here: <https://uark.pressbooks.pub/mechanicaldesign/?p=553#oembed-1>

GD&T Symbols

Go through the various symbols described here:

GD&T Symbols | GD&T Basics (gdandtbasics.com)

Any use that to determine what everything on the following part drawings means:

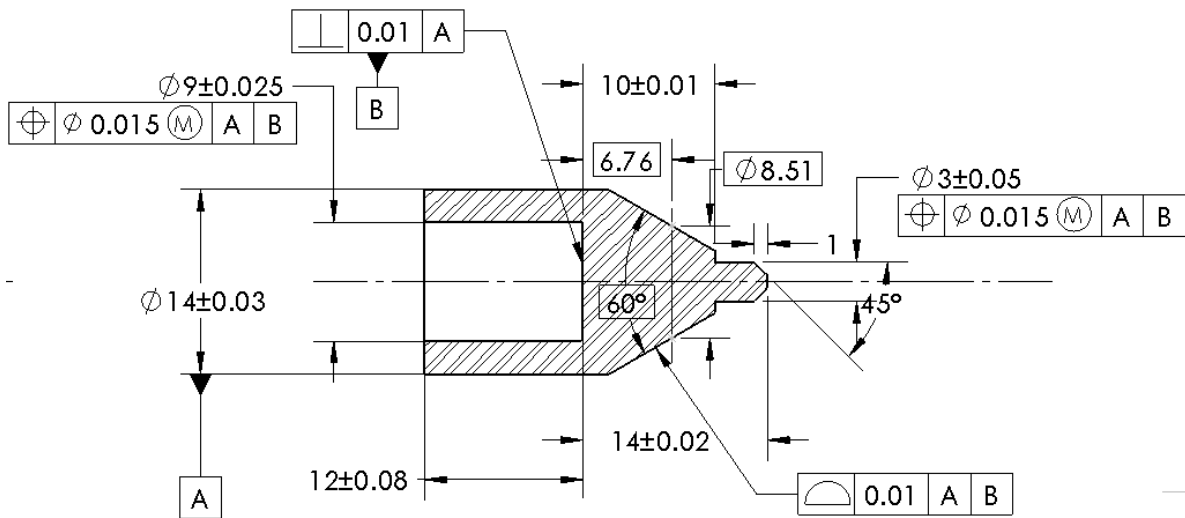

5 Steps to creating GD&T Drawings for Superior Quality (solidworks.com)

General Concepts for GD&T

A **feature** is any physical portion of a part, such as a surface, hole, slot, pin, etc. A feature can be either a feature of size or a non-size feature. A feature of size is one where the variation in its size affects the function or assembly of the part, such as a shaft diameter or a hole spacing. A non-size feature is one where the variation in its form, orientation or location affects the function or assembly of the part, such as a surface flatness or a hole perpendicularity.

A **feature control frame** is a rectangular box that contains the geometric characteristic symbol, the tolerance value, the datum references (if any), and any modifying symbols or modifiers. The feature control frame is attached to the dimension of the feature that it applies to by a leader line. The feature control frame specifies the tolerance zone for the feature and how it is related to other features or datums.

A **basic dimension** is a numerical value that defines the exact size, profile, orientation or location of a feature. It is usually shown in a rectangular box and does not have any tolerance associated with it. The tolerance for a basic dimension is specified by the feature control frame that references it. Basic dimensions are used to define the true profile or the true position of a feature.

A **datum feature symbol** is a label that identifies a physical feature of a part that acts as a datum. A datum is an imaginary plane, axis or point that serves as a reference for other features. A datum feature symbol consists

of a letter enclosed in a square frame, which is attached to the outline of the feature by a leader line. The letter indicates the order of precedence of the datum in relation to other datums.

A **feature of size** is one cylindrical or spherical feature, or two opposed elements or opposed parallel surfaces, associated with a size dimension. A feature of size has an axis (for cylinders or spheres) or a center plane (for opposed elements or surfaces) that can be used to establish a datum.

Full indicator movement (FIM) is the total movement of an indicator's measuring tip or contact point as it passes over an entire surface. FIM is used to measure surface variations such as flatness, straightness, circularity or cylindricity.

Least material boundary (LMB) is an imaginary boundary around a feature of size that represents the smallest size allowed by the tolerance. LMB is used when applying maximum material condition (MMC) modifier to an internal feature of size, such as a hole.

Least material condition (LMC) is the condition where an external feature of size (such as a shaft) contains the least amount of material within its tolerance zone, or where an internal feature of size (such as a hole) contains the most amount of material within its tolerance zone. LMC is used to specify assembly clearance between mating parts.

Maximum material boundary (MMB) is an imaginary boundary around a feature of size that represents the largest size allowed by the tolerance. MMB is used when applying maximum material condition (MMC) modifier to an external feature of size, such as a shaft.

Maximum material condition (MMC) is the condition where an external feature of size (such as a shaft) contains the most amount of material within its tolerance zone, or where an internal feature of size (such as a hole) contains the least amount of material within its tolerance zone. MMC is used to specify assembly interference between mating parts.

Projected tolerance zone is an imaginary cylinder or cone that extends beyond the surface of a hole or stud to control the position of another part that will be inserted into or over it. Projected tolerance zone is used when there is a functional requirement for alignment between mating parts beyond their mating surfaces.

Regardless of feature size (RFS) is a default condition that applies when no material condition modifier (such as MMC or LMC) is specified for a feature control frame. RFS means that the tolerance zone for the feature remains constant regardless of its actual size within its size tolerance.

Virtual condition is an imaginary boundary around a feature of size that represents the worst-case scenario for assembly with another part. Virtual condition is equal to MMB for external features and LMB for internal features when MMC modifier is applied, and equal to LMB for external features and MMB for internal features when LMC modifier is applied.

Types of Tolerances

Form Tolerances:

Flatness: A form tolerance that controls the deviation of a surface from a perfect plane. It can be applied to any surface, regardless of its size or shape.

Straightness: A form tolerance that controls the deviation of a line element or an axis from a perfect straight line. It can be applied to a feature of size (such as a cylinder) or to a non-size feature (such as a slot).

Circularity: A form tolerance that controls the deviation of a circular feature from a perfect circle. It can only be applied to circular features of size, such as holes or pins.

Cylindricity: A form tolerance that controls the deviation of a cylindrical feature from a perfect cylinder. It can only be applied to cylindrical features of size, such as shafts or bores.

Orientation Tolerance:

Parallelism: An orientation tolerance that controls the parallelism between two features or between a feature and a datum plane. It can be applied to any feature of size or non-size feature that has two parallel surfaces or elements, such as plates, blocks, slots, etc.

Perpendicularity: An orientation tolerance that controls the perpendicularity between two features or between a feature and a datum plane. It can be applied to any feature of size or non-size feature that has two perpendicular surfaces or elements, such as holes, pins, slots, etc.

Angularity: An orientation tolerance that controls the angular deviation between two features or between a feature and a datum plane. It can be applied to any feature of size or non-size feature that has two angular surfaces or elements, such as wedges, cones, slots, etc.

Runout Tolerances:

Runout: A composite tolerance that controls the variation in surface elements of a rotating part in relation to a datum axis during one full rotation. It is composed of two types: circular runout and total runout.

Circular Runout: A runout tolerance that controls the variation in circularity and coaxiality of a surface element at any given cross section of a rotating part in relation to a datum axis. It can be applied to any circular or cylindrical feature of size, such as rims, gears, shafts, etc.

Total Runout: A runout tolerance that controls the variation in circularity, coaxiality, straightness, taper, and profile of an entire surface of a rotating part in relation to a datum axis. It can be applied to any circular or cylindrical feature of size, such as drums, rollers, shafts, etc.

Profile Tolerance:

Profile of a Line: A profile tolerance that controls the variation in shape and location of an individual line element on a surface in relation to its true profile. It can be applied to any line element on any surface, regardless

of its size or shape, such as curves, contours, edges, etc.

Profile of a Surface: A profile tolerance that controls the variation in shape and location of an entire surface in relation to its true profile. It can be applied to any surface, regardless of its size or shape, such as planes, spheres, cones, etc.

Location Controls:

Concentricity: A location control that controls the coaxiality between two features or between a feature and a datum axis. It can be applied to any circular or cylindrical feature of size, such as holes, pins, shafts, etc.

Symmetry: A location control that controls the symmetry between two features or between a feature and a datum plane. It can be applied to any feature of size or non-size feature that has two symmetrical surfaces or elements, such as plates, blocks, slots, etc.

Position Tolerance: A location control that controls the variation in location of a feature or a group of features in relation to one or more datum features. It can be applied to any feature of size or non-size feature that has a defined position, such as holes, pins, slots, etc.

Follow along with the lecture below to understand how to put these concepts together.



One or more interactive elements has been excluded from this version of the text. You can view them online here: <https://uark.pressbooks.pub/mechanicaldesign/?p=553#oembed-2>

FITS AND TOLERANCES

One of the most significant parameters controlling the choice of manufacturing methods is the desired tolerance or the produced part. That is, to what exactness and allowed variance can part dimensions fluctuate such that they still perform their over-all function and can be properly assembled with other parts. Different manufacturing processes can produce parts with an expected amount of variation in their dimensions. Therefore, one of the first steps in design for manufacturing is determining the appropriate level of tolerance and correctly specifying that on part drawings and other related documentation. This section details tolerance selection in general and how to specify a desired tolerance.

Tolerancing

Tolerancing is the process of specifying the acceptable range of variation in the dimensions of a part. Tolerancing is essential for mass production, where assemblies must fit together with the goal of 100% interchangeability of parts. However, no part can be made exactly to the nominal size, which is the ideal or target dimension. Therefore, tolerancing allows for some deviation from the nominal size without compromising the functionality or quality of the product.

There are several terms and concepts related to tolerancing that a mechanical product designer should know. The **basic size** is the theoretical size used as a starting point for applying tolerances. The **limits** are the maximum and minimum permissible dimensions of a part. The **allowance** is the intentional difference between the **maximum material condition** (MMC) and the **least material condition** (LMC) of mating parts. The MMC is the condition where a part has the maximum amount of material within the specified limits. The LMC is the opposite condition, where a part has the minimum amount of material within the specified limits. These will be discussed further in the chapter on geometric dimensioning and tolerancing.

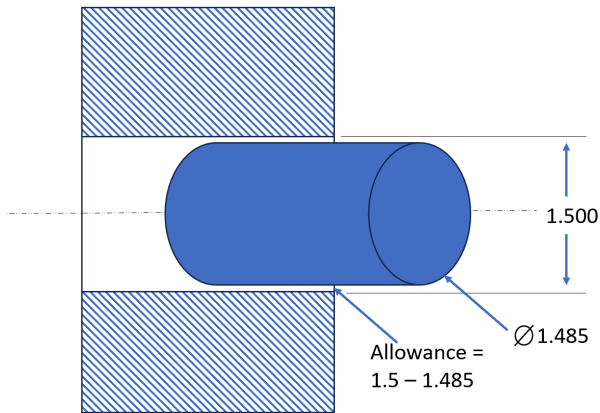

Allowance is the difference between mating parts at their material conditions.

Tolerances should be chosen very carefully by considering the requirements and constraints of the design problem. Tolerances must ensure that parts meet the desired quality standards and perform as intended. However, higher tolerances can also increase the cost of production exponentially, as they require more precise machines, tools, and inspection methods. Therefore, a good product designer should balance between quality and cost when selecting tolerances for parts. Note that default CAD modeling dimensions are often given in tighter tolerances than necessary and choosing these tolerances for no other reason can significantly increase the cost of production.

Tolerances are implemented through the manufacturing process and are specified on part drawings. There are different methods of reporting tolerance on a drawing or a model. One method is **limit dimensioning**, where the upper and lower limits are given directly. Another method is **unilateral tolerance**, where only one limit is given and the other limit is implied by adding or subtracting a tolerance value from the basic size. A third method is **bilateral tolerance**, where both limits are given by adding and subtracting a tolerance value from the basic size.

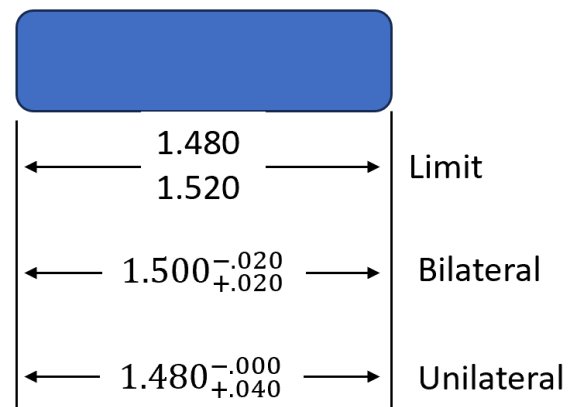

Tolerance is indicated one of three ways. Always be consistent. From Top to bottom, this show: limits, bilateral, and unilateral tolerance dimensions.

Selecting a Tolerance for Your Part

The goal of selecting a tolerance is to choose the least tight tolerance that results in acceptable quality and functionality of the part. A too tight tolerance means that the part has to be made with very high precision, which increases the cost and difficulty of manufacturing. A too tight tolerance also increases the risk of producing defective parts that do not meet the specification and have to be scrapped or recycled. On the other hand, a too loose tolerance may compromise the performance or reliability of the part, especially if it interacts with other parts in an assembly. A too loose tolerance may also affect the appearance or aesthetics of the part, which may be important for some applications.

Best practices for picking an appropriate tolerance are:

- Consider the function and purpose of the part. What are the critical dimensions that affect its performance? How does it fit with other parts in the system? What are the environmental conditions that may affect its dimensions, such as temperature, humidity, or wear?
- Use standard tolerances whenever possible. Standard tolerances are widely used and accepted in the industry and are based on empirical data and experience. They can simplify the design and manufacturing process and reduce errors and confusion. Standard tolerances can be found in various reference books, such as ANSI/ASME standards, ISO standards, or GD&T (Geometric Dimensioning and Tolerancing) standards.
- Use statistical methods to analyze the variation and distribution of dimensions. Statistical methods, such as Six Sigma, can help determine the optimal tolerance that minimizes defects and maximizes quality. Statistical methods can also help estimate the cost and benefit of different tolerance levels and compare them with customer requirements and expectations.
- Perform tolerance analysis and simulation to verify the design. Tolerance analysis is a method of calculating the cumulative effect of tolerances on a dimension or a feature. Tolerance analysis can help identify potential problems or conflicts in the design and evaluate the feasibility and robustness of the tolerance scheme. Tolerance simulation is a method of testing the design using computer models or physical prototypes that incorporate random variations in dimensions. Tolerance simulation can help validate the performance and functionality of the design under different scenarios and conditions.

Fits

A fit system is a way of specifying how much clearance or interference there is between two parts that are supposed to fit together. One of the most common fit systems is the hole/shaft system, which is based on an ANSI or ISO standard. This system applies to cylindrical parts that have a hole and a shaft that go into the hole.

There are three types of fits in the hole shaft system: clearance fits, interference fits, and transition fits. A clearance fit means that there is always some space between the hole and the shaft, even when they are pushed together as much as possible. That means when a shaft is produced at the largest of its allowed tolerance and the hole is made to the smallest of its allowed tolerance, there is still clearance between the parts. A clearance fit allows for easy assembly and disassembly, but it may result in some looseness or play between the parts. An interference fit means that there is always some overlap between the hole and the shaft, even when they are pulled apart as much as possible. An interference fit requires force or heat to assemble and disassemble, but it provides a tight and rigid connection between the parts. A transition fit means that there may be either

clearance or interference between the hole and the shaft, depending on the actual sizes of the parts. A transition fit can provide a moderate amount of tightness or looseness, depending on the application.

The ANSI and ISO standards (ANSI/ASME B4.1 and B4.2 and ISO 286-1 and 286-2) defines different classes of fits for each type of fit, based on how much tolerance is allowed for the hole and the shaft dimensions. The classes of fits are named using letters and numbers, such as RC, LC, LT, LN, and FN. The letters indicate the type of fit (R for running or sliding, L for location or alignment, F for force or shrink), and the numbers indicate the degree of tolerance (1 for very loose, 9 for very tight). For example, an RC1 fit is a very loose clearance fit, while an FN9 fit is a very tight interference fit.

The standard also uses capital letters for holes and lowercase letters for shafts. For example, a hole with an H7 tolerance means that its actual size can vary from 0 to +0.025 mm from its nominal size, while a shaft with an h6 tolerance means that its actual size can vary from 0 to -0.01 mm from its nominal size. If we want to have a transition fit between these two parts, we can use an H7/h6 fit designation. This means that the hole can have a diameter from 10 to 10.025 mm, while the shaft can have a diameter from 9.99 to 10 mm.

Using the Machinery's Handbook or online calculators (like this or this one) can help you determine the sizing and tolerancing for a desired fit.

When choosing a fit system for a design, we need to consider what we have more control over: the hole or the shaft. If we are using a standard component that has a fixed size, such as a bearing or a motor, we need to match our hole or shaft to that component. For example, if we have a bearing with an H7 tolerance, we need to make our shaft with an h6 or smaller tolerance to ensure a transition fit. If we have control over both the hole and the shaft dimensions, we may find it easier to make the shaft more precise than the hole, since it is usually easier to machine tighter tolerances on the shaft than a circular hole.

Another factor that affects our choice of fit system is the international tolerance grade (ITG) that defines how accurate our manufacturing process can be. The ITG ranges from IT01 (very high precision) to IT16 (very low precision), and it determines how much variation we can expect from our nominal dimensions. The ITG depends on the type of manufacturing method we use, such as turning, milling, drilling, etc. The higher the ITG, the larger the tolerance zone we need to allow for our parts. The ITG also helps us select the appropriate class of fit from the ANSI standard.

The hole shaft system is not limited to cylindrical parts only. We can also use it for other types of mating parts that require sliding or alignment, such as linear slides or guides. We just need to apply the same principles of clearance, interference, and transition fits to these parts as well.

The best way to understand fit systems is to physically try some fits yourself with parts and have a "feel" for the different types of fits. Second best, watch the video below to see the types of interference and best practices for specifying fit systems.

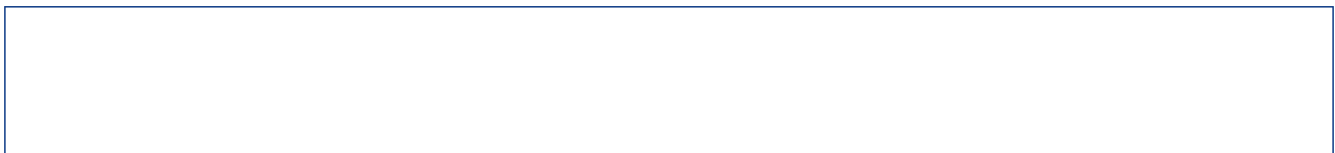



One or more interactive elements has been excluded from this version of the text. You can view them online here: <https://uark.pressbooks.pub/mechanicaldesign/?p=549#oembed-1>

WRAP-UP - DESIGN FOR MANUFACTURING AND ASSEMBLY

Design for Manufacturability (DFM) is a systematic approach to designing products that are easy and inexpensive to manufacture. It involves considering the manufacturing process at every stage of the design process, from selecting materials and processes to designing features that are easy to fabricate and assemble.

By following DFM principles, engineers can significantly reduce the cost and time it takes to bring a product to market.

Design for Assembly (DFA) is a similar approach to DFM, but it focuses specifically on making products easy to assemble. This involves considering the assembly process at every stage of the design process, from designing parts that fit together easily to minimizing the number of parts required.

Geometric Dimensioning and Tolerancing (GD&T) is a standardized language for communicating the geometric requirements of a part to a manufacturer. It uses symbols and modifiers to specify the exact shape, size, and location of features on a part, as well as the allowable tolerances for each feature.

GD&T is essential for ensuring that parts are manufactured to the correct specifications and that they will function properly when assembled.

Fit tables are tables that specify the recommended clearances and interferences between mating parts. They are based on the intended function of the joint and the materials used. Tolerances are the allowable variations in the dimensions of a part. They are necessary to account for the inherent variability of manufacturing processes.

Section Questions:



An interactive H5P element has been excluded from this version of the text. You can view it online here:

<https://uark.pressbooks.pub/mechanicaldesign/?p=606#h5p-12>

PART XI

MANUFACTURING - CASTING AND MOLDING PROCESS

Learning Objectives

This chapter discusses the design concerns for parts that are designed to be manufactured through metal casting processes. After completing this chapter, readers will be able to:

- Describe and compare metal casting processes.
- Compare expected quality and tolerance outcomes for different casting processes.
- Utilize best practices to design parts for metal casting to avoid defects and reduce costs.

Casting is a manufacturing method that involves pouring molten metal into a mold cavity and allowing it to solidify. The mold cavity is usually made of sand, metal, ceramic, or a combination of these materials. Casting can produce complex shapes that are difficult or impossible to achieve by other methods, such as machining or forging. Casting can also reduce the cost and waste of material, as the excess metal can be recycled. However, casting also has some limitations and challenges, such as defects, dimensional accuracy, surface finish, and environmental impact. Therefore, it is important to design the casting process and the cast parts carefully to optimize the quality and performance of the final product. This chapter will introduce the basic principles of casting, the types of casting processes and materials, and the design for casting best practices that can help engineers and designers to avoid common pitfalls and achieve successful casting outcomes.

METAL CASTING FUNDAMENTALS AND TERMS

Terminology

Casting metal is one of the oldest manufacturing methods known to humans. It involves creating a hollow shape or cavity, called a mold or casting, and filling it with a molten metal that solidifies into the desired part. The casting process can vary depending on the type of metal and the method of creating the mold. After the metal part is removed from the mold, it may undergo further processing such as machining, heat treatment, or surface finishing to achieve the required specifications and quality.

Designing for casting requires choosing the appropriate metal and casting method for the part. The choice depends on several factors such as the performance and material properties of the part, the dimensional accuracy and surface finish, and the production cost and time. Different metals have different melting points, fluidity, shrinkage, and mechanical properties that affect the casting process and outcome. Different casting methods have different advantages and disadvantages in terms of complexity, flexibility, repeatability, and efficiency.

Follow Along with Professor Cummings on Casting/Mold Fundamentals



One or more interactive elements has been excluded from this version of the text. You can view them online here: <https://uark.pressbooks.pub/mechanicaldesign/?p=717#oembed-1>

Metal Cast Part Properties and Behaviors

Using casting methods to generate metal parts affects the material properties and the places some restrictions on the realistically achievable dimensional tolerances. Why would you select casting compared to other ways of manufacturing a part such as machining or direct forming from blanks?

Some of the advantages of metal casting are:

- It can use metal alloys that are hard to work with using other methods, such as machining or welding. This gives more flexibility and variety in the choice of materials.
- It can produce complex shapes in large quantities cheaper than machining. This reduces the cost and time of production, especially for mass-produced parts.
- It can generate parts with internal cavity features more economically than other methods. This allows for the design of hollow or lightweight parts that can save material and improve performance.

However, metal casting also has some challenges or drawbacks, such as:

- Material properties in parts are often not anisotropic, meaning that they can be stronger in some directions than others. This can affect the performance and reliability of the parts, especially under stress or load.
- Casting can introduce defects such as poor surface finish, porosity, cracks or inclusions. These defects can reduce the quality and durability of the parts and may require additional processing or inspection to correct them.
- Achieving very tight dimensional tolerances is difficult with casting due to material shrinkage. This means that the parts may not fit well with other components or have gaps or misalignments. This can affect the functionality and aesthetics of the parts, and may require further machining or adjustment to fix them.

Watch Professor Cummings Explain What Happens to Metal When Cast



One or more interactive elements has been excluded from this version of the text. You can view them online here: <https://uark.pressbooks.pub/mechanicaldesign/?p=717#oembed-2>

TYPES OF CASTING PROCESS AND EXCEPTED TOLERANCES

Foundries

Foundries are the places where the casting process takes place. Different types of casting processes require different types of equipment and expertise. Therefore, most foundries focus on one or a few types of casting, such as sand casting, die casting, investment casting, etc.

For example, take a tour of the Lodge Cast Iron Cookware foundry and consider the investment and maintenance of the machines and support infrastructure.



One or more interactive elements has been excluded from this version of the text. You can view them online here: <https://uark.pressbooks.pub/mechanicaldesign/?p=541#oembed-1>

Material and Process Selection

One of the main factors that determines the suitability of a metal for a casting process is its melting temperature. Metals with higher melting temperatures require more energy and specialized equipment to melt and cast. Therefore, some metals are more commonly cast with processes that use lower temperatures, such as sand casting or investment casting. Other metals, such as aluminum or zinc, can be cast with processes that use higher temperatures, such as die casting or permanent mold casting. The choice of the casting process also depends on the desired properties and shape of the final product, as well as the cost and availability of the materials and equipment. The table below summarizes the typical casting processes for some common metals.

Process / Part Material	Die	Continuous	Investment	Permanant Mold	Plaster Mold	Centrifugal	Resin Shell	Sand
Ductile Iron		X	X			X	X	X
Steel			X			X	X	X
Stainless Steel			X			X	X	X
Aluminum / Magnesium	X		X	X	X		X	X
Bronze / Brass	X	X	X	X	X	X	X	X
Gray Iron		X		X		X	X	X
Malleable Iron							X	X
Zinc / Lead	X	X		X	X	X		X

Process and Tolerance Selection

Metal casting is a process of producing metal parts by pouring molten metal into a mold and letting it solidify. Different types of metal casting processes can result in different expected dimensional tolerances and surface condition tolerances. Dimensional tolerances are the allowable variations in the dimensions of a casting, while surface condition tolerances are the allowable variations in the surface roughness, defects and irregularities of a casting.

According to ISO 8062, a standard for castings dimensional tolerances and machining allowances, there are 16 tolerance grades for castings, ranging from CT1 to CT16, with CT1 being the most precise and CT16 being the least precise. The tolerance grade that can be achieved depends on several factors, such as the casting method, the metal type, the casting size, the casting complexity and the production volume.

In general, die casting and investment casting are considered precision casting methods due to the tighter tolerances that can be achieved compared to other methods. Both methods can produce castings with complex shapes, thin walls and fine details. According to SFSA Supplement 3, die casting can achieve a tolerance grade of CT4-CT6, while investment casting can achieve a tolerance grade of CT5-CT7.

Other casting methods, such as sand casting, permanent mold casting and centrifugal casting, have lower precision than die casting and investment casting. Sand casting is a process of forming a mold from sand and

pouring molten metal into it. Permanent mold casting is a process of using a reusable metal mold to produce castings. Centrifugal casting is a process of rotating a mold while pouring molten metal into it. These methods have limitations in producing complex shapes, thin walls and fine details. According to SFSA (Steel Founders of America) Supplement 3, sand casting can achieve a tolerance grade of CT9-CT13, permanent mold casting can achieve a tolerance grade of CT7-CT9 and centrifugal casting can achieve a tolerance grade of CT8-CT9.

Surface condition tolerances are also affected by the casting method, the metal type and the mold material. The surface roughness of a casting is measured by the arithmetic average deviation of the surface profile from a mean line (R_a) or by the maximum peak-to-valley height of the surface profile (R_z). The surface defects and irregularities of a casting include shrinkage, porosity, cracks, cold shuts, misruns, inclusions and flash. Different methods have different capabilities to control the surface quality of castings.

Die casting and investment casting can produce castings with smooth surfaces and minimal defects. Die casting can achieve an R_a value of 0.8-3.2 μm or an R_z value of 6.3-25 μm . Investment casting can achieve an R_a value of 1.6-6.3 μm or an R_z value of 12.5-50 μm . Both methods can reduce or eliminate shrinkage, porosity, cracks and inclusions by using high pressure, vacuum or controlled solidification.

Other methods have lower surface quality than die casting and investment casting. Sand casting can achieve an R_a value of 12.5-50 μm or an R_z value of 100-400 μm . Permanent mold casting can achieve an R_a value of 3.2-12.5 μm or an R_z value of 25-100 μm . Centrifugal casting can achieve an R_a value of 6.3-25 μm or an R_z value of 50-200 μm . These methods have more difficulties in preventing shrinkage, porosity, cracks and inclusions due to the lower pressure, higher gas content and less uniform cooling.

Therefore, different types of metal casting processes can result in different expected dimensional tolerances and surface condition tolerances. For more on various tolerance ranges consult standards associated with the material and process. For example, see: Casting Tolerances per. NADCA and ISO (engineersedge.com)

MULTIPLE USE CASTING AND MOLDS

Permanent Mold Casting

Permanent mold casting is a method of producing metal parts with molten metal under the pressure of gravity or a pressure feed system poured into a static mold. This method is very common for non-ferrous metals, such as aluminum, copper, and magnesium alloys. The advantages of permanent mold casting are that it can achieve higher dimensional and surface quality tolerance comparable to sand casting without secondary work, and that it has a lower cost per part for large run production. The main disadvantage of permanent mold casting is that the molds have high initial cost. While called permanent, molds can wear or fail over time due to thermal stress.



Molds for tin soldier toys from early 20th century. <https://upload.wikimedia.org/wikipedia/commons/6/64/Castingtinsoldiers.jpg>

Die Casting

Die casting is a method of producing metal parts by forcing molten metal into a mold or die under high pressure. This method is limited to low melting temperature metals, such as magnesium, aluminum, and zinc alloys. The advantages of die casting are that it can achieve complex feature geometry, hole tolerance comparable to drilling and boring machining process, and minimal secondary work to achieve desired surface tolerances. The main disadvantage of die casting is that the part geometry is limited in maximum thickness to allow the molten metal to fill the cavity without defects or voids.



One or more interactive elements has been excluded from this version of the text. You can view them online here: <https://uark.pressbooks.pub/mechanicaldesign/?p=543#oembed-1>

There are two major types of die casting: hot chamber and cold chamber. The difference between them is the temperature and pressure involved in the process. In hot chamber die casting, the molten metal is kept in a furnace attached to the machine, and a plunger pushes the metal into the die cavity. This method is faster and more efficient, but it can only be used for metals with low melting points that do not damage the furnace or the plunger. In cold chamber die casting, the molten metal is ladled from a separate furnace into a chamber, and then a plunger pushes the metal into the die cavity. This method is slower and less efficient, but it can be used for metals with higher melting points that would damage the furnace or the plunger in hot chamber die casting.

Hot Chamber Die Casting

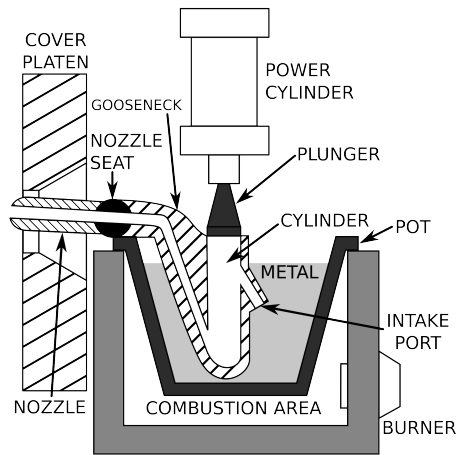

Schematic of a hot-chamber die casting machine.
https://en.wikipedia.org/wiki/Die_casting#/media/File:Hot-chamber_die_casting_machine_schematic.svg

Cold Chamber Die Casting

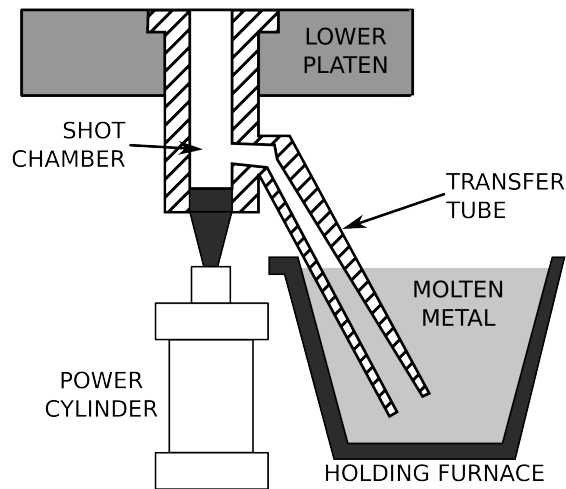

A schematic of a cold-chamber die casting machine. https://en.wikipedia.org/wiki/Die_casting#/media/File:Cold-chamber_die_casting_machine_schematic.svg

SINGLE USE MOLDS

Patterns and Molds

A pattern is a replica of the part that will be cast, with the same (or very similar) shape and dimensions. It is used to create a cavity in a mold material, where molten metal will be poured to form the part. Depending on the casting process, a pattern can be reusable or disposable. Reusable patterns are more durable and can make multiple molds, while disposable patterns are destroyed after making one mold. In sand casting and shell mold casting, the pattern is used to make many molds. While a new pattern is needed for each casting using investment and lost foam casting.

Green Sand Casting

Green-sand casting is a process in which a mold is made of moist sand mixed with clay and organic additives based on a multi-use pattern. The mold is then filled with molten metal and allowed to cool. After solidification, the mold is broken and the casting is removed.

Advantages:

- It is relatively inexpensive and easy to set up
- It can produce large and complex casting
- It can use both ferrous and non-ferrous metals

Drawbacks:

- It can produce poor surface finish and dimensional accuracy
- It can cause defects such as sand inclusion, gas porosity, and shrinkage

An example of a part commonly manufactured using green-sand casting is an engine block.



One or more interactive elements has been excluded from this version of the text. You can view them online here: <https://uark.pressbooks.pub/mechanicaldesign/?p=545#oembed-1>

Shell Molding

Shell molding is a process in which a thin shell of sand and resin is formed around a metal pattern. The pattern is then heated to cure the resin and harden the shell. The pattern is removed and the shell halves are joined together to form a mold. The mold is then filled with molten metal and allowed to cool. After solidification, the shell is broken and the casting is removed.

Advantages:

- It can produce high dimensional accuracy and surface finish
- It can produce thin and intricate castings
- It can reduce machining and cleaning costs
- It can use both ferrous and non-ferrous metals

Drawbacks:

- It is more expensive and complex than sand casting
- It can produce limited size and weight of castings
- It can cause defects such as gas porosity, hot tearing, and core shift

An example of a part commonly manufactured using shell molding is a valve body.



One or more interactive elements has been excluded from this version of the text. You can view them online here: <https://uark.pressbooks.pub/mechanicaldesign/?p=545#oembed-2>

Investment Casting

Investment casting, also known as lost wax casting, is a process in which a wax pattern is coated with refractory material to create a mold. The wax pattern is then melted out and the mold is filled with molten metal and allowed to cool. After solidification, the mold is broken and the casting is removed.

Advantages:

- It can produce high dimensional accuracy and surface finish
- It can produce complex and intricate castings
- It can produce near-net-shape castings with minimal machining

- It can use a wide range of metals, including alloys and superalloys

Drawbacks:

- It is more expensive and time-consuming than other casting methods
- It can produce limited size and weight of castings
- It can cause defects such as gas porosity, shrinkage, and cracking

An example of a part commonly manufactured using investment casting is a turbine blade.



One or more interactive elements has been excluded from this version of the text. You can view them online here: <https://uark.pressbooks.pub/mechanicaldesign/?p=545#oembed-3>

Lost Foam Casting

Evaporative casting, also known as lost foam casting, is a process in which a foam pattern is coated with refractory material and placed in a sand mold. The mold is then filled with molten metal and the foam pattern evaporates. After solidification, the sand mold is broken and the casting is removed. This type of casting can also be useful in generate small batches or single parts in the prototyping stage as well as full production.

Advantages:

- It can produce high dimensional accuracy and surface finish
- It can produce complex and intricate castings
- It can produce near-net-shape castings with minimal machining
- It can eliminate the need for cores or risers

Drawbacks:

- It can produce poor mechanical properties due to gas entrapment
- It can cause defects such as sand inclusion, gas porosity, and shrinkage

An example of a part commonly manufactured using evaporative casting is an engine cylinder head.



One or more interactive elements has been excluded from this version of the text. You can view them online here: <https://uark.pressbooks.pub/mechanicaldesign/?p=545#oembed-4>

POWDER METAL PROCESSES

Powder metallurgy is the process of manufacturing parts using metal powders. Composites can also be generated by combining metal powder with nonmetals, commonly ceramic. This enables designers to achieve specific material properties in their parts.

One of the advantages of powder metallurgy is that it can produce complex shapes with minimal material waste and high precision. However, due to process limitations, powder-based manufactured parts are size and weight limited. Typically, they are under 2 inches in thickness and under 35 lbs per part.

General Powder Metallurgy Process

Generating metal powder involves reducing the size of metal pieces or ingots into fine particles by various methods, such as atomization, mechanical milling, or chemical reduction. The size, shape, and distribution of the metal powder affect the properties and performance of the final part.

Blending is the process of mixing different metal powders or adding nonmetallic additives to create a homogeneous mixture with the desired composition and characteristics. Blending can improve the strength, hardness, corrosion resistance, or wear resistance of the part.

Compacting is the process of applying pressure to the blended powder to form a coherent mass with a specific shape and size. Compacting can be done by using a die and a punch, a roller, or an isostatic press. The compacted powder is called a green part, which has low strength and density.

Sintering is the process of heating the green part to a temperature below the melting point of the metal powder, but high enough to cause diffusion and bonding between the particles. Sintering increases the strength and density of the part, as well as reduces porosity and improves dimensional stability.



One or more interactive elements has been excluded from this version of the text. You can view them online here: <https://uark.pressbooks.pub/mechanicaldesign/?p=577#oembed-1>

Secondary Processes

The secondary processes typically used for powder metallurgy manufacturing are machining, sintering, heat treatment, and surface finishing. Machining is used to improve the dimensional accuracy and surface quality of the parts. Sintering is used to bond the metal particles together and increase the strength and density of the parts. Heat treatment is used to modify the mechanical properties and microstructure of the parts. Surface finishing is used to enhance the appearance, corrosion resistance, and wear resistance of the parts.

Other Powder Metal Methods

Isostatic Compaction

Isostatic compaction is a mass-conserving shaping process that applies uniform pressure on a powder mass in a flexible mold. The pressure can be applied by a fluid, such as water or oil, or by a gas, such as argon or nitrogen. Isostatic compaction can produce parts with high and uniform density, complex shapes, and fine details. Isostatic compaction can be performed at room temperature (cold isostatic pressing) or at elevated temperature (hot isostatic pressing).

Metal Injection Molding

Metal injection molding (MIM) is a metalworking process that combines the advantages of powder metallurgy and plastic injection molding. Finely-powdered metal is mixed with a binder material to create a feedstock that is then injected into a mold and solidified. The molded part is then removed from the mold and subjected to debinding and sintering processes to remove the binder and densify the metal particles. MIM can produce small, complex-shaped metal parts with outstanding mechanical properties, high accuracy, and excellent surface finish. MIM can use a variety of metals, such as stainless steel, titanium, copper, tungsten, and cobalt-chromium.



One or more interactive elements has been excluded from this version of the text. You can view them online here: <https://uark.pressbooks.pub/mechanicaldesign/?p=577#oembed-2>

DESIGN FOR CASTING AND MOLDING PRINCIPLES AND BEST PRACTICES

Types of Defects

Cast metal parts are prone to certain defects based on the type of process and material used. Some of the common defects are:

Misrun: A misrun is a defect where the metal does not fill the mold cavity completely, resulting in a thin or incomplete casting. It is caused by low pouring temperature, high viscosity of the molten metal, insufficient fluidity, or improper design of the gating system.

Cold Shut: A cold shut is a defect where two streams of metal do not fuse properly in the mold cavity, creating a discontinuity or a crack in the casting. It is caused by low pouring temperature, high pouring speed, insufficient fluidity, or turbulence in the molten metal.

Porosity: Porosity is a defect where there are small holes, voids, or pockets of air in the casting. It is caused by trapped gas in the molten metal, improper venting of the mold or core, excessive moisture in the mold or core, or low permeability of the sand.

Shrinkage Void: A shrinkage void is a defect where there is a cavity or a depression in the casting due to insufficient feeding of the molten metal during solidification. It is caused by high pouring temperature, large temperature gradient, improper design of the riser or feeder, or insufficient contraction allowance.

Hot tear: A hot tear is a defect where there is a crack or a fracture in the casting due to thermal stress during solidification. It is caused by high pouring temperature, high cooling rate, low ductility of the metal, or improper design of the mold or core.

Core Shift: A core shift is a defect where there is a misalignment of the core in the mold cavity, resulting in a deviation from the desired shape or dimension of the casting. It is caused by improper alignment of the core, loose core prints, insufficient support for the core, or excessive pressure of the molten metal.

Inclusion: An inclusion is a defect where there are foreign materials such as slag, sand, oxide, or metal particles embedded in the casting. It is caused by improper cleaning of the furnace or ladle, improper fluxing of the molten metal, improper gating system, or formation of insoluble compounds during solidification.

DFM for Metal Casting

The design of casting parts should consider the material properties, the casting process, and the part requirements to ensure optimal performance, quality, and cost-effectiveness.

Some of the design for manufacturing (DFM) principles for casting parts are:

- Choose the appropriate material and process for the part function, specification, and quality level. Different materials have different melting points, fluidity, shrinkage, and mechanical properties that affect the casting process and the final part characteristics. Different casting processes have different advantages and disadvantages in terms of accuracy, surface finish, production rate, and complexity.
- Design the part geometry to facilitate smooth and complete filling of the mold cavity. The part should have uniform wall thickness to avoid hot spots and cold spots that can cause warping, cracking, or porosity. The part should also have smooth transitions and rounded corners to reduce turbulence and resistance in the liquid metal flow. The part should avoid undercuts or features that require side cores or slides that can increase the mold complexity and cost.
- Design the part orientation and ejection mechanism to minimize defects and damage. The part should be oriented in the mold such that the direction of mold closure is perpendicular to the largest cross-section of the part. This can reduce the number of parting lines and improve the dimensional accuracy and surface quality of the part. The part should also have adequate draft angles and ejection pins or sleeves to facilitate easy removal from the mold without causing deformation or scratches. Additionally, the simpler the ejection system the cheaper the dies and molds will be.

More detailed DFM for Casting and Powder Metallurgy can be found in the ASM Metals Handbook.

Section Questions:



An interactive H5P element has been excluded from this version of the text. You can view it online here:

<https://uark.pressbooks.pub/mechanicaldesign/?p=547#h5p-13>

PART XII

MANUFACTURING - FORMING AND SHAPING PROCESSES

Learning Objectives

This chapter covers metal forming process common in part manufacturing and some principles of design for manufacturing for this manufacturing method. By the end of this chapter, reader will be able to:

- Describe the processes of metal forging, extrusion, rolling and drawing.
- Describe the types of sheet metal work.
- Apply principles of DFM for bulk metal forming and sheet metal work.

Metal forming is a process of shaping metal workpieces into desired geometries by applying controlled forces. Metal forming processes can be classified into bulk deformation and sheet metal forming, depending on the thickness-to-width ratio of the workpiece. Bulk deformation processes, such as forging, extrusion, and rolling, involve large plastic deformations and significant changes in the cross-sectional area of the workpiece. Sheet metal forming processes, such as bending, deep drawing, and stamping, involve relatively small thickness changes and shape the workpiece into a thin-walled shell.

Design for manufacturing (DFM) for formed metal parts involves considering the material selection, geometry, tolerances, surface finish, and process parameters of the metal forming processes. DFM can help to avoid defects, such as cracking, wrinkling, springback, and residual stresses, that may occur during metal forming. Implementing DFM can also reduce the number of operations, tools, and dies required for metal forming, thereby saving time and resources.

METAL FORMING PROCESS TYPES AND TOLERANCES

Cold, Warm, and Hot Forming

Metal forming is the process of shaping metal parts by applying temperature and pressure. The choice of forming method depends on the desired material properties, such as elasticity, strength, and hardness. Different forming methods can affect these properties in different ways. Forming can also involve multiple steps to achieve the required tolerance and desired properties. In addition, secondary machining operations are often used to refine the shape and surface of the formed parts.

Bulk metal forming is a type of forming that involves large deformations of metal. It can be classified into three categories: cold work, warm work, and hot work.

Cold work is performed at room temperature or below the recrystallization temperature of the metal, typically less than 30% of melting temperature. It has several advantages, such as producing a good surface finish, achieving tight dimensional tolerance, and inducing strain hardening in the material. Strain hardening increases the strength and hardness of the metal, but also reduces its ductility and formability. Cold work also requires high forming force, which can increase the wear and tear of the tools and equipment. Moreover, cold work has limitations on the cross-section size of the metal, as larger sections are more difficult to deform at low temperatures. Cold work is suitable for producing parts with high accuracy and surface finish, but it requires high forces and may cause cracking or fracture.

Warm work is performed above the recrystallization temperature but below the melting point of the metal, typically between 30%-60% of melting temperature. It has some benefits, such as providing a medium surface finish, maintaining medium dimensional tolerance, and causing some strain hardening in the material. Strain hardening in warm work is less than in cold work, as some of the dislocations in the metal are annealed during the process. Warm work also requires medium forming force, which can reduce the energy consumption and tool wear compared to cold work. However, warm work still has some drawbacks, such as possible oxidation and scaling of the metal surface, and potential warping and distortion of the final product. Warm work is suitable for producing parts with moderate accuracy and surface finish, but it requires lower forces and less energy than cold work. Warm work also reduces the residual stresses and improves the microstructure of the metal.

Hot work is performed above the recrystallization temperature and close to the melting point of the metal, typically between 60%-90% of melting temperature. It reduces the strength and hardness of the metal significantly but increases its ductility and formability greatly. It produces a poor surface finish and looser

dimensional tolerance than warm and cold work. However, strain hardening in hot work is negligible, as the metal recrystallizes continuously during the process. Hot work also requires low forming force, which can enable large deformations and complex shapes. Furthermore, hot work has no size limitations on the cross section of the metal, as any section can be deformed at high temperatures. Hot work is suitable for producing parts with complex shapes and large deformations, but it requires high temperatures and energy, and may cause oxidation or scaling. Hot work also reduces the residual stresses and improves the microstructure of the metal.

Watch Professor Cummings explain how work affects the microstructure and material properties.



One or more interactive elements has been excluded from this version of the text. You can view them online here: <https://uark.pressbooks.pub/mechanicaldesign/?p=555#oembed-1>

Tolerance Specification

Suppliers of stock material generated through bulk forming process often provide tolerances which are based on ASTM (American Society of Testing and Materials) standards. It is based on both the geometry of the part and the material. For example, see OnlineMetals tolerance charts for stock material: Material Dimensional Tolerances | OnlineMetals.com®

ROLLING

Rolling Temperature

Rolling is a metalworking technique that involves compressing a part between two rotating cylinders, called rollers, to reduce its thickness and make it more uniform. Rolling can be classified into three types, depending on the temperature of the part: hot, warm or cold. **Hot rolling** is performed at temperatures above the recrystallization point of the metal, which allows for large deformations without increasing the strength or hardness of the material. **Warm rolling** is done at intermediate temperatures, where some recrystallization occurs but not enough to prevent strain hardening. **Cold rolling** is done at room temperature or below, where the metal becomes stronger and harder due to work hardening, but also more brittle and prone to cracking.

One example of a rolling process is the production of billets from cast ingots. Billets are long bars with a constant rectangular cross section, which can be further processed into various shapes and products, such as I beams, tubes, rods, bars and so on. To make billets, cast ingots are first heated to a high temperature and then passed through a series of rollers that gradually reduce their thickness and width. The final product has a smooth surface and a uniform grain structure. Billets can also be rolled into different shapes by changing the shape of the rollers or by using additional tools, such as mandrels or dies.

Cold rolling can be used to create shapes that are similar to those obtained by extrusion, which is another metalworking technique that involves forcing a part through a die to create a cross-sectional profile. However, unlike extrusion, cold rolling requires that the wall thickness of the part be uniform throughout, otherwise the rollers will not be able to apply equal pressure and cause defects. Cold rolling can produce high-quality products with tight tolerances and smooth surfaces, but it also requires more energy and causes more wear on the tools.

When a part undergoes multiple stages of rolling, from hot to cold, it may develop surface oxides and scales due to exposure to air and heat. These impurities can affect the quality and appearance of the final product, as well as interfere with subsequent processes such as welding or coating. To remove them, a process called pickling is performed, which involves immersing the part in an acid solution that dissolves the oxides and scales. Pickling also helps to improve the corrosion resistance and adhesion of the metal surface.

Hot Rolling

Factory producing a variety of stocks and components using Hot rolling (and come cold work as well)



One or more interactive elements has been excluded from this version of the text. You can view them online here: <https://uark.pressbooks.pub/mechanicaldesign/?p=557#oembed-1>

Cold Rolling

Reduce sheet thickness using cold rolling:



One or more interactive elements has been excluded from this version of the text. You can view them online here: <https://uark.pressbooks.pub/mechanicaldesign/?p=557#oembed-2>

DRAWING

Drawing is the process of reducing cross sectional diameter of wire, bar or tube. This is done by applying a tensile force to the material and pulling it through a die with a smaller opening than the original cross section. Drawing usually occurs at room temperature, which induces strain hardening in the material and increases its strength and hardness. Most drawing processes are performed over several steps, with each step reducing the diameter by a certain percentage. The final product has a uniform cross section and improved surface finish. Some examples of components that are generated through drawing are nails, screws, bolts, wires, cables, rods, tubes and pipes.



One or more interactive elements has been excluded from this version of the text. You can view them online here: <https://uark.pressbooks.pub/mechanicaldesign/?p=561#oembed-1>

FORGING

Forging is the process of causing bulk plastic deformation to achieve a desired shape and material microstructure. It is usually done as hot work, meaning that the metal is heated above its recrystallization temperature before being deformed. A traditional blacksmith working an anvil and hammer is an example of forging. Forging can create directional microstructure alignment, which leads to being more ductile and stronger than casting. Thus, forged metals are more resistant to shock and fatigue failure.

There are different types of forging, depending on the shape of the die and the degree of material flow. **Open die forging** is when the metal is compressed between two flat or simple-shaped dies, allowing the metal to flow freely in all directions. **Closed die forging** is when the metal is confined within a cavity or impression that matches the final shape of the part. **Impression die forging** is a type of closed die forging that uses dies with multiple cavities or impressions to produce complex shapes. **Precision forging** is a type of closed die forging that uses dies with very high accuracy and surface finish to produce parts with minimal or no machining.

Some guidelines for part design for forging are:

- Avoid sharp corners, undercuts, and thin sections that may cause stress concentration or cracking.
- Provide generous fillets and radii to facilitate material flow and reduce die wear.
- Design parts with uniform cross-sections and symmetrical shapes to reduce forging load and avoid defects.
- Minimize the number of operations and dies required to produce the part.
- Consider the effect of forging on the grain structure and mechanical properties of the metal.

Hot Forging

The benefits of hot forging include high strain rates, homogenized grain structure, increased ductility, and reduced hardening force. The drawbacks of hot forging include less accurate tolerances and the possibility of warping during cooling.



One or more interactive elements has been excluded from this version of the text. You can view them online here: <https://uark.pressbooks.pub/mechanicaldesign/?p=753#oembed-1>

Cold Forging

Cold forging is a manufacturing process that shapes metal at room temperature by applying compressive forces. It has some advantages and disadvantages compared to hot forging. Some of the benefits of cold forging are: no waste material, little or no finishing work, high dimensional accuracy, and excellent surface quality. Some of the drawbacks of cold forging are: reduced plasticity and toughness of the metal, higher deformation force required, residual stress inside the metal, and deformation or fracture of metal grains. Cold forging is often used in the automotive industry to produce simple shapes in high volumes.



One or more interactive elements has been excluded from this version of the text. You can view them online here: <https://uark.pressbooks.pub/mechanicaldesign/?p=753#oembed-2>

EXTRUSION

Extrusions is a process of forming parts with a constant cross-sectional shape by forcing a metal through a die or a set of dies. The metal undergoes plastic deformation as it is squeezed through the opening of the die, which determines the shape and size of the final product. Extrusions can be used to produce rods, tubes, wires, and other complex shapes from metals such as aluminum, copper, steel, and titanium.

There are three main methods of extrusion: direct, indirect, and hydrostatic.

In **direct extrusion**, also known as forward extrusion, the metal billet is placed in a container and pushed by a ram through the die. The container and the die move in the same direction, creating friction between the billet and the container walls. This friction increases the force required to extrude the metal and reduces the quality of the surface finish. Direct extrusion is the most common and economical method of extrusion.

In **indirect extrusion**, also known as **backward extrusion**, the metal billet is stationary and the die moves towards it. The die is attached to a hollow ram that fits over the billet. As the ram pushes the die against the billet, the metal flows backwards through the opening in the ram. Indirect extrusion eliminates the friction between the billet and the container walls, reducing the force required to extrude the metal and improving the surface quality. However, indirect extrusion requires more complex equipment and is less suitable for producing long products.

In **hydrostatic extrusion**, the metal billet is placed in a chamber filled with a pressurized fluid, usually oil. The fluid acts as a cushion that prevents direct contact between the billet and the container walls. A ram pushes the fluid against the billet, forcing it to flow through the die. Hydrostatic extrusion reduces friction and increases ductility, allowing for higher extrusion ratios and lower temperatures. However, hydrostatic extrusion is more expensive and requires special seals and pumps to maintain the fluid pressure.

Extrusion can be performed at different temperature ranges: cold, warm, or hot. Cold extrusion is done at or near room temperature, resulting in high strength, high accuracy, and good surface finish. However, cold extrusion requires high forces and is limited by the ductility of the metal. Cold extrusions is limited in the complexity of the shape and the maximum reduction from blank to extruded shape that can be achieved without heating the metal. Warm extrusion is done at temperatures below the recrystallization temperature of the metal, which increases its ductility and reduces its strength. Warm extrusion allows for lower forces and higher speeds than cold extrusion but may compromise surface quality and dimensional accuracy. Warm and cold extrusion can also be done quickly and with less environmental impact than hot extrusions. Hot extrusion is done at temperatures above the recrystallization temperature of the metal, which reduces its strength and increases its ductility to a maximum level. Hot extrusion requires low forces and allows for high extrusion ratios and complex shapes. However, hot extrusion may cause oxidation, grain growth, and surface defects.



One or more interactive elements has been excluded from this version of the text. You can view them online here: <https://uark.pressbooks.pub/mechanicaldesign/?p=559#oembed-1>

Designing for and Using Extrusions

A very large variety of aluminum (and other metal) extrusions can be purchased from suppliers that can often meet design needs for building things like structural support members. See: T-Slot Extrusions from 80/20. These types of solutions can also include standardized components for connections and attachments, simplifying the design process.

For custom extrusion, you will work with a supplier to develop die design to meet your part specification needs. The die and the design time to develop them are high in cost and only justified if standard extrusions will not satisfy requirements and production volume is high.

SHEET METAL WORK

Sheet Metal Basics

Sheet metal is a common type of material that can be used for various applications. It is a flat and thin piece of metal that can be cut, stamped, and shaped into different forms and shapes. Some examples of products that use sheet metal are car bodies, airplane wings, kitchen utensils, and metal roofs.

Sheet metal stock is specified by the dimensions of the sheet, the type of material, and the gauge. The **gauge** is a measure of the thickness of the sheet metal, and it varies depending on the material. For example, a 14-gauge steel sheet is 1.897 mm thick, while a 14-gauge aluminum sheet is 1.628 mm thick. A table of common metal gauges and weights can be found here: <https://www.custompartnet.com/sheet-metal-gauge>.

Working with sheet metal is not a simple task. It usually involves multiple steps and processes to achieve the desired part geometry. The main challenge of sheet metal design is to choose the right process and the right order for each step. The process and order depend on factors such as the material properties, the thickness, and the available machines.

Sheet Metal Work Processes

Sheet metal forming is a manufacturing process that uses various techniques to shape thin metal sheets into desired parts. There are a large variety of processes with subtle differences that can be used to achieve a desired shape from sheet metal. Some of the most common processes are:

Shearing

This is a process that cuts sheet metal by applying shear stress along a straight line. The sheet metal is placed between two blades, one fixed and one moving, that create a shearing force to separate the metal. There are different types of shearing methods, each using a different type of tool:

- **Blanking:** This is a method that cuts out a piece of sheet metal with a desired shape and size, leaving behind a scrap. The piece that is cut out is called a blank, and it can be used for further processing. The tool used for blanking is called a punch and die, which have matching shapes to create the blank.
- **Fine Blanking:** This is a method that produces blanks with smooth edges and high accuracy. It uses a

higher pressure and a smaller clearance between the punch and die than regular blanking. It also uses a blank holder to prevent the sheet metal from bending or tearing during the cutting process.

- **Dinking:** This is a method that cuts out small and irregular shapes from sheet metal, such as washers, gaskets, or buttons. It uses a hand-operated tool called a dinking machine, which has a sharp steel punch and a rubber pad. The punch is pressed against the sheet metal on the pad, creating a hole or a cutout.
- **Lancing:** This is a method that cuts sheet metal partially, leaving one end attached to the original sheet. This creates a slit or a tab that can be bent or folded for various purposes, such as ventilation, fastening, or joining. The tool used for lancing is also a punch and die, but with a gap between them to allow the sheet metal to remain connected.
- **Punching:** This is a method that creates holes in sheet metal by removing circular pieces of metal. The tool used for punching is also a punch and die, but with circular shapes to create the holes. The pieces of metal that are removed are called slugs, and they are usually discarded as waste.
- **Nibbling:** This is a method that cuts sheet metal by making small and overlapping cuts along a contour. It can create complex shapes and curves from sheet metal without using a specific tool. The tool used for nibbling is called a nibbler, which has a reciprocating blade that moves up and down to cut the sheet metal.
- **Notching:** This is a method that removes material from the edge or corner of sheet metal by making V-shaped or U-shaped cuts. It can be used to create slots, grooves, or angles in sheet metal for various purposes, such as bending, joining, or strengthening. The tool used for notching is also a punch and die, but with V-shaped or U-shaped shapes to create the notches.

Forming

Forming is changing the sheet metal geometry to achieve shapes beyond the flat two-dimensions of the sheet. These process can require some initial stamping to support proper forming. Common types of forming include:

- **Bending:** This process involves bending the sheet along a straight line or a curved path, using a press brake or a bending machine. The tool used for bending is called a die, which has a matching shape to the bend angle and radius.
- **Drawing:** This process involves stretching the sheet into a cup or a box shape, using a punch and a die. The punch pushes the sheet into the die cavity, which has a larger diameter or depth than the sheet thickness.
- **Stretch forming:** This process involves stretching the sheet over a curved surface, using a clamp and a form block. The clamp holds the sheet at both ends, while the form block applies tension and pressure to the sheet, causing it to conform to the curved shape.
- **Spinning:** This process involves rotating the sheet at high speed around an axis, using a lathe or a

spinning machine. The tool used for spinning is called a roller, which contacts the sheet and gradually shapes it into a cone or a cylinder.

- **Flanging:** This process involves bending the edge of the sheet at an angle, using a flanging machine or a hammer. The tool used for flanging is called a flange, which has a groove or a notch that fits the edge of the sheet.
- **Hemming:** This process involves folding the edge of the sheet over itself, using a hemming machine or a press. The tool used for hemming is called a hemmer, which has a flat surface that presses the folded edge.
- **Roll bending:** This process involves bending the sheet into a circular or elliptical shape, using a roll bending machine or a roller. The tool used for roll bending is called a roll, which has a cylindrical or conical shape that rotates and bends the sheet.

When designing parts to be formed from sheet metal, you will need to consider the following:

- **Spring back:** This is the tendency of the sheet to return to its original shape after being bent or stretched. It is caused by the elastic recovery of the metal, which reduces the accuracy and consistency of the formed part. To compensate for spring back, the tooling must have an overbend or an overstretch angle that exceeds the desired angle by an amount equal to the spring back angle.
- **Minimum bend radii:** This is the smallest radius that can be achieved without causing cracks or tears in the sheet. It depends on the material properties, thickness, and grain direction of the sheet. To avoid cracking or tearing, the bend radius must be greater than or equal to the minimum bend radius for the given sheet material and thickness.
- **Required Force** (or pressure): This is the amount of force that must be applied to deform the sheet into the desired shape. It depends on the material properties, thickness, geometry, and friction of the sheet and the tooling. To reduce the force required, lubricants can be used to reduce friction, or thinner sheets can be used to reduce resistance.

The order of steps is important for sheet metal shearing and forming to achieve the desired end part. Consider the process shown below:



One or more interactive elements has been excluded from this version of the text. You can view them online here: <https://uark.pressbooks.pub/mechanicaldesign/?p=575#oembed-1>

Progressive Work and Tool & Die Design

Progressive stamping is a metal forming process that uses a series of dies to create complex parts from sheet metal. The sheet metal is fed into the press by a coil or strip, and each die station performs a different operation on the metal, such as cutting, bending, punching, or drawing. The final part is produced after the metal passes through all the die stations in one stroke of the press.

Draw die design is a subset of **tool and die design** that focuses on creating dies for deep drawing operations. Deep drawing is a process that forms sheet metal into cylindrical or box-shaped parts by pulling the metal into a die cavity with a punch. Draw die design involves determining the optimal blank shape and size, draw reduction ratios, draw depth, blank holder pressure, lubrication, and material properties to achieve the desired part geometry and quality.



One or more interactive elements has been excluded from this version of the text. You can view them online here: <https://uark.pressbooks.pub/mechanicaldesign/?p=575#oembed-2>

CAD Part Design

A sheet metal toolbox is a feature of many CAD software such as Solidworks that allows users to design and manipulate sheet metal parts. Sheet metal toolbox also helps users to flatten sheet metal parts, generate drawings, and export data for manufacturing.

For a simple example, see:



One or more interactive elements has been excluded from this version of the text. You can view them online here: <https://uark.pressbooks.pub/mechanicaldesign/?p=575#oembed-3>

DESIGN FOR FORMING PRINCIPLES AND PRACTICES

Forming is the process of achieving part shape by applying external forces to a metal material. This chapter covered different types of forming processes that can be used for bulk metal materials or sheet metal stock. Some of these processes are rolling, drawing, forging and extrusion. Each of these processes has its own advantages and limitations, and requires careful consideration of design for manufacturing (DFM) guidelines to ensure quality, efficiency and cost-effectiveness.

Design for Forming by Rolling and Drawing

- Choose a suitable material that can withstand the high compressive stresses and strains involved in these processes.
- Minimize the number of rolling or drawing passes to reduce the amount of material waste and energy consumption.
- Avoid sharp corners, abrupt changes in cross-section or complex shapes that can cause defects such as cracks, tears or wrinkles.
- Provide adequate lubrication and cooling to reduce friction, heat generation and tool wear.
- Control the rolling or drawing speed, temperature and pressure to achieve the desired dimensions, tolerances and surface finish.

For more information, see: Rolling and Drawing Manufacturing.

Design for Forming by Forging

- Choose a suitable material that has good ductility, strength and resistance to deformation at high temperatures.
- Design the part with uniform cross-sections, smooth transitions and generous fillets to avoid stress concentrations and cracking.
- Minimize the number of forging operations and use preforms or intermediate shapes to reduce the amount of material deformation and heating required.
- Provide sufficient draft angles, clearances and allowances to facilitate the removal of the part from the die

and account for shrinkage and distortion.

- Use appropriate heating, cooling and quenching methods to control the microstructure, mechanical properties and residual stresses of the forged part.

For more information, see: Forging.

Design for Forming by Extrusion

- Choose a suitable material that has good extrudability, meaning it can flow easily through the die without cracking or breaking.
- Design the part with constant cross-sections, symmetrical shapes and balanced wall thicknesses to ensure uniform material flow and extrusion pressure.
- Avoid features that can cause die wear, such as sharp edges, deep grooves or small holes.
- Provide adequate lubrication and cooling to reduce friction, heat generation and tool wear.
- Control the extrusion speed, temperature and pressure to achieve the desired dimensions, tolerances and surface finish.

For more information, see: Extrusion.

Design for Forming with Sheet Metal

- Choose a suitable material that has good formability, meaning it can bend, stretch or shear without cracking or breaking.
- Design the part with simple shapes, large radii and gentle curves to avoid excessive deformation and springback.
- Minimize the number of bends, cuts or holes to reduce the amount of material waste and processing time.
- Provide adequate bend allowances, clearances and margins to account for the material thickness, bend radius and tooling dimensions.
- Use appropriate methods for joining, fastening or finishing the sheet metal part, such as welding, riveting or painting.

For more information, see: Sheet Metal Forming.

Section Questions:



An interactive H5P element has been excluded from this version of the text. You can view it online here:

<https://uark.pressbooks.pub/mechanicaldesign/?p=563#h5p-14>

PART XIII

MANUFACTURING - MACHINING PROCESSES

Learning Objectives

Machining is a process of removing material to achieve the desired shape and surface quality of the part. After completing this chapter, reader will be able to:

- Describe the basic machining processes.
- Estimate the relative cost for machining a part.
- Describe and apply design for machining principles.

This chapter covers basic concepts and methods of machining, which is one of the most common manufacturing processes. Machining involves cutting, drilling, milling, turning and other operations that remove material from a workpiece to create a desired shape and surface finish. Machining can be done manually by skilled operators or automatically by machines controlled by computer programs. The main design for machining (DFM) principles are to minimize the machining time and cost by optimizing the part geometry, material selection, tolerance specification and machining strategy. By applying these principles, engineers can design parts that are easier and cheaper to manufacture, while meeting the required performance and quality standards.



One or more interactive elements has been excluded from this version of the text. You can view them online here: <https://uark.pressbooks.pub/mechanicaldesign/?p=176#oembed-1>

TYPES OF CUTTING AND MACHINING PROCESS AND TOLERANCES

Machining is a manufacturing method that involves removing material from a workpiece using a cutting tool. Machining can produce parts with high accuracy and surface finish, but it also requires careful design considerations to optimize the process and reduce the cost. In this chapter, we will discuss some of the important aspects of design for machining, such as cutting tool nomenclature, machining cost and tool life.

Cutting Tool Nomenclature

A cutting tool is the device that performs the actual material removal in machining. It has various features that affect its performance and suitability for different operations. The following table summarizes some of the common terms used to describe a cutting tool and their meanings.

Term	Description
Base	The part of the tool that is clamped or held by the machine
Cutting Edge	The edge of the tool that contacts and cuts the workpiece
Cutting Angle	The angle between the cutting edge and the direction of tool motion
Back-Rake Angle	The angle between the face and a plane perpendicular to the base
Side-Rake Angle	The angle between the face and a plane parallel to the base
Face	The surface of the tool that is perpendicular to the cutting edge
Flank	The surface of the tool that is adjacent to and behind the cutting edge
Size	The dimensions of the tool, such as length, width and thickness
Shank	The part of the tool that extends from the base and connects to the machine
Tool Point	The tip or end of the tool where the cutting edges meet

Machining Cost and Tolerance

The cost of machining a part depends on several factors, such as the type of machining process, the material properties, the part geometry, the surface finish and the dimensional tolerance. Generally, machining processes can be classified into two categories: roughing and finishing. Roughing processes remove large amounts of material quickly but produce low accuracy and surface finish. Finishing processes remove small amounts of material slowly but produce high accuracy and surface finish. Therefore, a trade-off exists between machining time and quality.

The tolerance is the allowable deviation from a specified dimension or feature. It reflects the degree of precision required for a part. A tighter tolerance means a higher precision, but also a higher machining cost. Therefore, designers should specify tolerances that are appropriate for the function and performance of the part and avoid over-tolerancing or under-tolerancing.

Machining Defects and Tool Life

Machining is a complex process that involves high temperatures, pressures, stresses and friction. These factors can cause various defects in the machined part or wear in the cutting tool. Some of the common machining defects and tool wear mechanisms are listed in the following table.

Defect or Wear Type	Description
Flank Wear	The gradual wear of the flank surface due to abrasion by the workpiece material
Crater Wear	The formation of a depression on the face surface due to diffusion or chemical reaction between the tool and workpiece materials
Diffusion	The transfer of atoms between the tool and workpiece materials due to high temperature and contact pressure
Adhesion/ Attrition	The welding or tearing of material from one surface to another due to high temperature and friction
Chipping	The breaking or cracking of a small portion of the cutting edge due to impact or thermal shock
Built-up Edge	The accumulation of workpiece material on the cutting edge due to adhesion or plastic deformation
Notching Wear	The formation of grooves or notches on the cutting edge due to abrasion by hard particles or inclusions in the workpiece material
Plastic Deformation	The permanent change in shape or size of the tool due to high temperature and stress

Tool life is defined as the time that a cutting tool can perform satisfactorily before it needs to be replaced or reconditioned. Tool life is affected by many factors, such as cutting speed, feed rate, depth of cut, tool geometry, tool material, workpiece material, coolant, etc. One of the empirical models used to estimate tool life is given by:

$$V * T^n = C$$

Where V is the cutting speed, T is tool life and C and n are constants that depend on various machining parameters. This equation implies that increasing the cutting speed will decrease tool life exponentially, and vice versa.

Watch Professor Cummings' Video on Cutting Tools



One or more interactive elements has been excluded from this version of the text. You can view them online here: <https://uark.pressbooks.pub/mechanicaldesign/?p=565#oembed-1>

Expected Tolerances

Read through the following helpful guide on expected tolerances for common machining processes.

Guide for Machining Tolerances

The international tolerance grades (IT grades) are a system of standardized tolerances for designing mechanical components. They specify the allowable deviation from a nominal dimension for different manufacturing processes. The IT grades range from IT01 to IT18, with lower numbers indicating higher precision and smaller tolerances. The IT grade for a given dimension can be calculated using the formula:

$$T = 0.45 \cdot D^{\frac{1}{3}} \cdot 10^{0.2 \cdot ITG}$$

where T is the tolerance in micrometers, D is the geometric mean dimension in millimeters, and ITG is the IT grade number.





One or more interactive elements has been excluded from this version of the text. You can view them online here: <https://uark.pressbooks.pub/mechanicaldesign/?p=565#oembed-2>

MILLING

What is Milling:



One or more interactive elements has been excluded from this version of the text. You can view them online here: <https://uark.pressbooks.pub/mechanicaldesign/?p=569#oembed-1>

Milling is a type of machining process that uses a rotating cutting tool to remove material from a workpiece. Milling can create a variety of shapes and features on a part, such as slots, holes, pockets, and contours.

There are different types of milling machines that can be used for different purposes.

Standard vertical milling machine: This machine has a vertical spindle that holds the cutting tool perpendicular to the workpiece. The spindle can move up and down along the column to adjust the cutting depth. The workpiece is usually mounted on a table that can move in three directions: left-right, front-back, and up-down.

Horizontal knee and column milling machine: This machine has a horizontal spindle that holds the cutting tool parallel to the workpiece. The spindle can move along the column to adjust the cutting position. The workpiece is usually mounted on a table that can move in two directions: left-right and front-back. The table can also be tilted or swiveled to create angled cuts.

CNC milling machine: This machine uses computer numerical control (CNC) to automate the movement of the spindle and the table according to a programmed code. CNC milling machines can perform complex and precise operations that are difficult or impossible to do manually. CNC milling machines can have either vertical or horizontal spindles, or both.

Machining center: This machine is a type of CNC milling machine that has additional features, such as automatic tool changers, multiple spindles, and rotary tables. Machining centers can perform multiple operations on a single workpiece without manual intervention.

Milling Operations

Slab milling: This operation uses a flat cutting tool to remove material from the surface of a workpiece. The cutting tool moves along the length or width of the workpiece, creating a flat or stepped surface.

Face milling: This operation uses a cutting tool with multiple teeth to remove material from the face or end of a workpiece. The cutting tool rotates perpendicular to the workpiece, creating a smooth or rough surface.

End milling: This operation uses a cutting tool with one or more flutes to remove material from the edge or corner of a workpiece. The cutting tool rotates parallel to the workpiece, creating a groove or profile.

The cutting in milling operations can be performed in two different ways: conventional or up milling and climb or down milling. These terms refer to the direction of rotation of the cutting tool relative to the direction of feed of the workpiece.

Conventional or up milling: This method has the cutting tool rotate against the direction of feed of the workpiece. This creates more friction and heat at the point of contact, which can cause more wear and tear on the tool and the workpiece. However, this method also provides more support for the workpiece and prevents it from being lifted by the cutting force.

Climb or down milling: This method has the cutting tool rotate in the same direction as the feed of the workpiece. This creates less friction and heat at the point of contact, which can result in better surface finish and longer tool life. However, this method also requires more rigidity and accuracy in the machine and the workpiece, as any backlash or vibration can cause chatter and damage.

Designing Parts to be Milled

Milling operations are often done with multiple passes and cutting tool changes, which add time and cost to the machining process. Therefore, it is important to design parts that can be machined using milling efficiently and effectively.

- Minimize the number of features and dimensions that require milling, especially those that require complex or angled cuts.
- Use standard sizes and shapes for holes, slots, pockets, and contours, as they can be machined using standard tools and speeds.
- Avoid sharp corners and edges, as they can cause stress concentration and cracking. Use fillets, chamfers, or radii instead.
- Avoid thin walls and deep cavities, as they can cause deflection and vibration. Use ribs, webs, or supports instead.
- Avoid undercuts, overhangs, or internal threads, as they require special tools or operations that increase complexity and cost.

DRILLING, BORING, BROACHING, AND TAPPING

Hole features are among the most common processes in machining, as they are essential for creating mating parts and installing fasteners. However, not all holes are created equal, and different methods of hole forming may be required depending on the specifications of the design.

One of the main factors that determines the method of hole forming is the desired allowable tolerance. The tolerance affects the fit, function and performance of the mating parts or fasteners. For example, a tight tolerance may be needed for a precise fit, while a loose tolerance may allow for some clearance or adjustment.

Another factor that influences the method of hole forming is the shape, size and presence of threads for fasteners. The method of hole forming must be compatible with the type and size of threads required for the fastener.

There are a number of methods for forming holes in machining, such as drilling, reaming, boring, tapping, threading and broaching. Each method has its own advantages and disadvantages, depending on the accuracy, quality and efficiency of the process. The Machinist Handbook and other similar resources can provide the typical achievable tolerance ranges for different types of hole forming.

For example, see: [Drill Tolerance: Accuracy Considerations in Engineering Design – EngineerExcel](#)

ISO 286 is an international standard that defines tolerance grades for holes and shafts. Tolerance grades are numerical values that indicate the magnitude of the permissible deviation from the nominal dimension. The lower the tolerance grade, the tighter the tolerance. For example, a hole with a tolerance grade of 6 has a smaller deviation than a hole with a tolerance grade of 10. ISO 286 also provides tables and charts that show the corresponding tolerance values for different nominal dimensions and tolerance grades.

Drilling

Drilling is a machining process that involves creating holes in a work piece by rotating a cutting tool. The cutting tool, also called a drill bit, has different sizes that are standardized by various systems, such as fractional, metric, wire gauge, and letter sizes. There are also different types of drilling operations that can produce different shapes and sizes of holes. Some examples are:

- Core drilling: This is used to enlarge an existing hole by removing the core of the material.
- Step drilling: This is used to create holes with different diameters at different depths.

- Counterboring: This is used to create a flat-bottomed hole that can accommodate the head of a screw or bolt.
- Countersinking: This is used to create a conical hole that can fit the head of a screw or bolt flush with the surface of the work piece.
- Reaming: This is used to improve the accuracy and finish of a hole by removing a small amount of material with a cutting tool called a reamer.
- Center drilling: This is used to create a small hole at the center of a work piece that can serve as a guide for subsequent drilling operations.

Read more about drill bit nomenclature and see comparative images of the above processes here: [How Drilling Machine Works? | Different Types – ExtruDesign](#)



One or more interactive elements has been excluded from this version of the text. You can view them online here: <https://uark.pressbooks.pub/mechanicaldesign/?p=571#oembed-1>



One or more interactive elements has been excluded from this version of the text. You can view them online here: <https://uark.pressbooks.pub/mechanicaldesign/?p=571#oembed-2>

Boring

Boring is a machining process that involves enlarging or finishing an existing hole with a single point cutting tool. Boring can achieve high precision and accuracy in terms of hole diameter, roundness, and surface finish. The strength of the cutting tool is the main factor that determines the speed and rate of material removal in boring. A stronger tool can withstand higher cutting forces and temperatures, and thus enable faster and deeper boring operations.





One or more interactive elements has been excluded from this version of the text. You can view them online here: <https://uark.pressbooks.pub/mechanicaldesign/?p=571#oembed-3>

Broaching

Broaching is a machining process that uses a toothed tool called a broach to create holes or slots in a workpiece. Broaching is suitable for high-precision and high-volume production of various shapes, such as circular, square, hexagonal, or keyway holes. However, broaching also poses some challenges due to the high force needed to push or pull the broach through the workpiece. The high force can cause deflection, vibration, or wear of the broach or the workpiece, affecting the accuracy and quality of the machined surface. Therefore, broaching requires careful design of the broach geometry, cutting parameters, and fixture system to ensure a smooth and efficient operation.



One or more interactive elements has been excluded from this version of the text. You can view them online here: <https://uark.pressbooks.pub/mechanicaldesign/?p=571#oembed-4>

Thread Tapping

Tapping is a process of creating internal threads in a hole using a tool called a tap. A die is a tool that creates external threads on a rod or a bolt. Taps and dies are usually standardized according to different thread standards, such as the Unified Thread Standard (UTS).

When designing for tapping, there are some factors to consider. One is to minimize the depth of the hole that needs to be threaded. According to the UTS, the recommended depth is 75% of the nominal diameter of the thread. This ensures sufficient strength and reduces the risk of breaking the tap. Another factor is the material hardness of the workpiece. Harder materials require more cutting force and may wear out the tap faster. Therefore, it is advisable to use high-quality taps and appropriate cutting fluids for tapping hard materials. Finally, it is important to use standardized dies for creating external threads that match the internal threads created by the tap. This ensures compatibility and interchangeability of threaded parts.



One or more interactive elements has been excluded from this version of the text. You can view them online here: <https://uark.pressbooks.pub/mechanicaldesign/?p=571#oembed-5>

TURNING



One or more interactive elements has been excluded from this version of the text. You can view them online here: <https://uark.pressbooks.pub/mechanicaldesign/?p=567#oembed-1>

Turning is a machining process that involves the use of a cutting tool to remove material from a rotating workpiece. The cutting tool is typically held in a fixed position and moved along one or more axes to create the desired shape and size of the workpiece. Turning is one of the most common and versatile machining processes, as it can produce cylindrical, conical, helical, or spherical shapes. The cutting tool can also be used in the center of the work piece in the case of center hole boring, a common process in gear manufacturing for example.

A **lathe** is the machine tool that performs turning operations. The main parts of a lathe are the headstock, the tailstock, the carriage, and the bed. The headstock holds and rotates the workpiece, while the tailstock supports the other end of the workpiece. The carriage moves along the bed and carries the cutting tool, which is mounted on a tool post. The carriage can be controlled by hand or by a power feed mechanism. The bed is the rigid base of the lathe that supports all the other parts.

The turning process is controlled by several factors, such as the speed of rotation of the workpiece, the feed rate of the cutting tool, the depth of cut, and the geometry and material of the cutting tool. These factors affect the quality and accuracy of the turned part, as well as the tool life and power consumption. The optimal values of these factors depend on the type and condition of the workpiece material, the desired shape and size of the part, and the machining requirements.

GRINDING AND POLISH

Grinding and polishing are common finishing processes that enhance the quality of the surface features of a workpiece. While machining can achieve the desired dimensional accuracy and tolerance, grinding and polishing can improve the surface roughness, flatness, and reflectivity.

Grinding machines use abrasive wheels that rotate at high speed to remove material from the workpiece by abrasion. The abrasive grains on the wheel act as cutting tools that create small chips on the workpiece surface. There are different types of grinding machines, such as cylindrical, surface, centerless, and internal grinding machines, depending on the shape and size of the workpiece and the desired finish.

The abrasion process can be classified into two types: ductile-mode and brittle-mode. In ductile-mode abrasion, the material is plastically deformed and removed by shear. In brittle-mode abrasion, the material is fractured and removed by tensile stress. The type of abrasion depends on the properties of the workpiece material, the abrasive grains, and the grinding conditions.

One of the main concerns in grinding is the wheel wear, which affects the performance and efficiency of the process. The wheel wear can be caused by three mechanisms: attritious wear, grain fracture, and bond fracture. Attritious wear occurs when the abrasive grains lose their sharpness due to rubbing against the workpiece. Grain fracture occurs when the abrasive grains break into smaller pieces due to excessive force or temperature. Bond fracture occurs when the bond material that holds the grains together breaks due to fatigue or thermal stress.

The material removal rate (MRR) in grinding is a measure of how much material is removed from the workpiece per unit time. The MRR depends on several factors, such as the force applied on the wheel, the wheel speed, the workpiece speed, the depth of cut, and the grinding ratio. The grinding ratio is defined as the ratio of the volume of material removed from the workpiece to the volume of material removed from the wheel. A high grinding ratio means that the wheel wears less and lasts longer.

Polishing is a process that uses finer abrasives or polishing compounds to create a smooth and shiny surface on a workpiece. Polishing can reduce or eliminate surface defects such as scratches, pits, and marks that are left by previous machining or grinding operations. Polishing can also improve the corrosion resistance, wear resistance, and aesthetic appeal of a workpiece.

There are different methods of metal polishing, such as mechanical polishing, electrochemical polishing, and chemical polishing. Mechanical polishing uses abrasive tools or media that rub against the workpiece surface to remove a thin layer of material. Electrochemical polishing uses an electric current to dissolve the surface irregularities of a workpiece immersed in an electrolytic solution. Chemical polishing uses a chemical solution to etch away the surface roughness of a workpiece.

Watch Professor Cumings' Introductory Lecture on Grinding



One or more interactive elements has been excluded from this version of the text. You can view them online here: <https://uark.pressbooks.pub/mechanicaldesign/?p=573#oembed-1>

FINISHING TREATMENT PROCESSES

Most machined parts need secondary operations including finishing to achieve tolerances and meet desired functional or behavioral requirements. Finishing operations can improve the surface quality, dimensional accuracy, and geometric accuracy of the machined parts.

Deburring

Deburring is the removal of metal fragments that are not completely removed in the machining process. These fragments, also known as burrs, can affect the performance, safety, and aesthetics of the machined parts.

Deburring can be done by different methods depending on the size, shape, and quantity of the machined parts. For small batches of simple parts, deburring can be done manually by using tools such as files, scrapers, brushes, or sandpaper. Manual deburring is labor-intensive, time-consuming, and inconsistent, but it can be suitable for low-volume production or prototyping.

For large batches of complex parts, deburring can be done by using automated or semi-automated processes that can handle a large number of parts simultaneously. Some of these processes are:

- **Tumbling:** This process involves placing the parts in a rotating or vibrating barrel along with abrasive media such as ceramic chips, steel balls, or sand. The friction and impact between the parts and the media remove the burrs and polish the surface of the parts.
- **Vibratory finishing:** This process is similar to tumbling, but instead of rotating, the barrel vibrates at a high frequency and amplitude. This creates a more gentle and uniform action on the parts and reduces the risk of damaging or deforming them.
- **Abrasive-flow:** This process involves forcing a viscous abrasive paste through the holes, slots, or cavities of the parts. The paste acts as a flexible file that conforms to the shape of the part and removes the burrs from the internal surfaces.
- **Thermal energy methods:** These methods use heat to melt or vaporize the burrs from the parts. Examples of these methods are flame deburring, plasma deburring, laser deburring, and electron beam deburring. These methods are fast and precise, but they can also affect the metallurgical properties of the parts.
- **Electrochemical methods:** These methods use an electric current to dissolve the burrs from the parts. Examples of these methods are electrochemical deburring and electrochemical machining. These methods are effective for removing burrs from hard-to-reach areas, but they can also cause corrosion or

hydrogen embrittlement of the parts.

- Wire brushing: This process involves using a rotating wire brush to scrape off the burrs from the parts. This method is simple and inexpensive, but it can also leave scratches or marks on the surface of the parts.



One or more interactive elements has been excluded from this version of the text. You can view them online here: <https://uark.pressbooks.pub/mechanicaldesign/?p=579#oembed-1>

Honing

Honing is an abrasive process that uses a rotating tool with abrasive particles to remove material from the surface of a workpiece. The purpose of honing is to achieve a precise final size and shape, and to correct any imperfections that may have occurred during the machining process. Honing can improve the surface finish, geometric accuracy, and dimensional tolerance of the workpiece.

Honing is often needed for tight tolerance fits, such as in bearings, cylinders, valves, and gears. These components require a high degree of precision and smoothness to function properly and reduce friction, wear, and noise. Honing can be used to fix various types of errors that may affect the quality of the machined surface, such as:

- Out-of-roundness: when the diameter of the workpiece varies along its length or circumference.
- Taper: when the diameter of the workpiece changes gradually from one end to another.
- Barrel shape: when the diameter of the workpiece is larger in the middle than at the ends.
- Bell-mouth shape: when the diameter of the workpiece is larger at one end than at the other.
- Ovality: when the cross-section of the workpiece is not circular but elliptical.
- Bore distortion: when the shape of the workpiece is affected by external forces or stresses.
- Surface roughness: when the surface of the workpiece has irregularities or scratches that reduce its smoothness.



One or more interactive elements has been excluded from this version of the text. You can view them online here: <https://uark.pressbooks.pub/mechanicaldesign/?p=579#oembed-2>

Lapping

Lapping is a finishing process that uses loose abrasives to smooth and refine the surface of a workpiece. Lapping can achieve **extreme accuracy** of dimensions, shape, and surface finish, as well as correct minor imperfections and produce a close fit between mating surfaces. Lapping can also reduce the internal stresses in a workpiece by lapping both sides simultaneously, resulting in improved flatness and parallelism.

Lapping involves rubbing the workpiece against a lapping plate or tool that is coated with abrasive particles. The abrasive particles can be in the form of paste, liquid, or powder. The lapping plate or tool can be either fixed or rotating, depending on the type of lapping machine. Lapping can be done manually or mechanically, depending on the size and quantity of the workpieces.



One or more interactive elements has been excluded from this version of the text. You can view them online here: <https://uark.pressbooks.pub/mechanicaldesign/?p=579#oembed-3>

Shot-Peening

Shot peening is a method of cold working that improves the mechanical properties of metals and composites by creating a compressive residual stress layer on the surface. This process involves striking the surface with shot, which are round metallic, glass, or ceramic particles, with enough force to cause plastic deformation.

One of the applications of shot peening is to remove stress concentrations that can lead to fatigue failure or stress corrosion cracking. By inducing compressive stresses on the surface, shot peening prevents the propagation of cracks that can initiate from tensile stresses or defects.

Shot peening is commonly used in mechanical springs, such as coil springs, leaf springs, and torsion bars. These components are subjected to cyclic loading and bending stresses that can cause fatigue damage over time.



One or more interactive elements has been excluded from this version of the text. You can view them online here: <https://uark.pressbooks.pub/mechanicaldesign/?p=579#oembed-4>

Electropolishing and Electroplating

Electropolishing is a process that removes a thin layer of metal from the surface of a workpiece, using an electrolytic solution and an electric current. Electropolishing treats the whole workpiece uniformly, regardless of its shape or size. Some of the benefits of electropolishing are:

- It improves the surface finish and reduces the roughness, resulting in a smooth and shiny appearance.
- It removes burrs, sharp edges, and other defects that can cause stress concentration and fatigue failure.
- It enhances the corrosion resistance and chemical stability of the metal, by removing impurities and contaminants.
- It reduces the friction and wear of the metal, by creating a lubricious and non-stick surface.
- It increases the cleanliness and hygiene of the metal, by eliminating microorganisms and organic residues.

Electropolishing is widely used in industries that require high-quality metal parts, such as aerospace, medical, pharmaceutical, food, and semiconductor.



One or more interactive elements has been excluded from this version of the text. You can view them online here: <https://uark.pressbooks.pub/mechanicaldesign/?p=579#oembed-5>

Electroplating is a process that uses an electric current to deposit a thin layer of metal on the surface of another metal. Electroplating can be done over the whole workpiece or only on selected areas, depending on the desired outcome. Some of the benefits of electroplating are:

- It can improve the appearance, corrosion resistance, and durability of the metal.
- It can modify the electrical conductivity, magnetic properties, or friction coefficient of the metal.
- It can reduce the cost of using expensive metals by applying them only on the surface of cheaper metals.



One or more interactive elements has been excluded from this version of the text. You can view them online here: <https://uark.pressbooks.pub/mechanicaldesign/?p=579#oembed-6>

Anodizing

Anodizing is a process that creates a protective oxide layer on the surface of metals, such as aluminum, titanium, and magnesium. The oxide layer is formed by applying an electric current to the metal in an electrolytic solution, which causes the metal to oxidize and form a thin, hard, and corrosion-resistant coating.

Some of the benefits of anodizing are:

- It enhances the appearance and durability of the metal, giving it a range of colors and finishes that can be customized according to the design specifications.
- It increases the resistance of the metal to wear, abrasion, corrosion, and heat, making it suitable for various applications and environments.
- It improves the adhesion of paints, glues, and other coatings to the metal surface, allowing for better bonding and performance.
- It reduces the maintenance and repair costs of the metal parts, as they are less prone to damage and degradation over time.



One or more interactive elements has been excluded from this version of the text. You can view them online here: <https://uark.pressbooks.pub/mechanicaldesign/?p=579#oembed-7>

Coating

Polymer coating is a process of applying a thin layer of polymer material on a substrate to enhance its properties and protect it from corrosion. Polymer materials are composed of large molecules that are formed by joining smaller units called monomers. Some examples of polymer materials are resins and plastics. There are different types of polymer coating materials, such as epoxy, polyester, vinyl ester, and phenolic, that have different

characteristics and applications. The methods of polymer coating can vary depending on the type of material, the substrate, and the desired performance. Some common methods are spraying, dipping, brushing, and electrostatic deposition.



One or more interactive elements has been excluded from this version of the text. You can view them online here: <https://uark.pressbooks.pub/mechanicaldesign/?p=579#oembed-8>

DESIGN FOR MACHINING PROCESSES

Design for machining is a design strategy that aims to reduce the cost and time of manufacturing a product by minimizing the amount of material removal and machining operations. Some of the best practices for design for machining include:

- Use standard shapes and sizes of raw materials whenever possible or create the desired shape by forming methods such as bending, stamping, or forging, rather than by machining.
- Specify the loosest tolerances that still meet the functional requirements of the product, as tighter tolerances increase the machining time and complexity.
- Avoid sharp internal corners and other features that require turning, as they can cause stress concentration, tool wear, and surface defects. Instead, use chamfers or radii to smooth out the transitions.
- For milling operations, round out the external corners and avoid narrow or deep features that require small or long cutting tools. Smaller tools have lower feed rates and higher deflection, which can affect the accuracy and quality of the machined part.
- Specify fillets and other radii based on the available sizes of the cutting tools, rather than arbitrary values. This can reduce the number of tools needed and simplify the machining process.



One or more interactive elements has been excluded from this version of the text. You can view them online here: <https://uark.pressbooks.pub/mechanicaldesign/?p=595#oembed-1>

Section Questions:



An interactive H5P element has been excluded from this version of the text. You can view it

online here:

<https://uark.pressbooks.pub/mechanicaldesign/?p=595#h5p-15>

PART XIV

MANUFACTURING - JOINING PROCESSES

Learning Objectives

In this chapter we talk about the joining processes of welding, soldering and brazing. Using fasteners is also a type of joining, however that was covered in previous chapters. By the end of this chapter, readers will be able to:

- Compare different welding methods and technologies.
- Describe the soldering and brazing method of joining.
- Identify cost effective methods to either avoid joining or reduce the cost of joining operations.

Putting one or more piece together to form a permanent shape is called joining. Joining methods can affect the cost, quality, performance, and reliability of a product, so they should be carefully selected based on the design requirements and constraints. In this chapter, we will introduce some of the most common joining methods, such as brazing and soldering, welding, and fasteners, and discuss their advantages and disadvantages, as well as their applications and limitations.

WELDING METHODS

Welding is a joining method that involves melting and fusing the edges of two or more metal parts together. There are different types of welding, depending on the equipment, the power source, the shielding gas, and the filler material used. Some of the most common types of welding are:

- **MIG (metal inert gas) welding:** This type of welding uses a continuous wire electrode that is fed through a welding gun and forms an arc with the workpiece. The electrode also acts as a filler metal, and a shielding gas (usually argon or carbon dioxide) protects the weld pool from atmospheric contamination.
- **TIG (tungsten inert gas) welding:** This type of welding uses a non-consumable tungsten electrode that creates an arc with the workpiece. A separate filler metal is added manually or automatically, and a shielding gas (usually argon or helium) protects the weld pool from atmospheric contamination. TIG welding produces high-quality welds but requires more skill and precision than MIG welding.
- **Stick (shielded metal arc) welding:** This type of welding uses a consumable electrode that is coated with a flux that produces a protective gas and slag when burned. The electrode forms an arc with the workpiece and melts both the base metal and the filler metal. Stick welding is simple and versatile, but it produces more spatter and slag than other types of welding.
- **Fluxcore (flux-cored arc) welding:** This type of welding is similar to MIG welding, but it uses a tubular wire electrode that contains a flux core instead of a solid core. The flux core produces a shielding gas and slag when burned, eliminating the need for an external gas supply. Fluxcore welding is suitable for outdoor applications and can weld thicker materials than MIG welding.
- **Ultrasonic welding:** This type of welding uses high-frequency vibrations to create heat and pressure at the interface of two metal parts. The vibrations cause plastic deformation and interlocking of the metal grains, forming a solid-state bond. Ultrasonic welding does not require filler metal or shielding gas, and it can weld dissimilar metals and thin materials.
- **Friction welding:** This type of welding uses rotational or linear motion to generate friction and heat at the interface of two metal parts. The friction causes plastic deformation and interlocking of the metal grains, forming a solid-state bond. Friction welding does not require filler metal or shielding gas, and it can weld dissimilar metals and complex shapes.



One or more interactive elements has been excluded from this version of the text. You can view them online here: <https://uark.pressbooks.pub/mechanicaldesign/?p=581#oembed-1>

Avoiding Welding Defects

There are many potential errors that can occur during metal welding, which can compromise the quality, strength, and appearance of the weld. Some of the common errors are:

- **Porosity:** This is the formation of gas bubbles or holes in the weld, which reduce its density and durability. Porosity can be caused by contamination, improper shielding gas, excessive welding speed, or incorrect electrode angle. To avoid porosity, it is important to clean the base metal and the filler material before welding, use the appropriate gas flow rate and type, adjust the welding parameters, and maintain a steady arc length and travel speed.
- **Inclusions:** These are foreign materials that get trapped in the weld, such as slag, flux, or oxides. Inclusions can weaken the weld and cause cracks or corrosion. Inclusions can be prevented by removing slag or flux between each pass, using a proper welding technique, and choosing a compatible filler material.
- **Undercutting:** This is a groove or notch that forms along the edge of the weld, which reduces its cross-sectional area and makes it prone to cracking. Undercutting can result from excessive heat input, high welding current, incorrect electrode angle, or poor fit-up. To prevent undercutting, it is advisable to use a lower heat input and current, hold the electrode perpendicular to the joint, and ensure a good gap and alignment between the base metal pieces.
- **Poor joint penetration:** This is when the weld does not fully fuse with the base metal, leaving gaps or voids in the joint. Poor joint penetration can affect the strength and performance of the weld. It can be caused by insufficient heat input, low welding current, improper joint design, or incorrect electrode size. To improve joint penetration, it is recommended to use a higher heat input and current, select a suitable joint type and preparation, and use an appropriate electrode diameter.
- **Burn-through:** This is when the weld melts through the base metal, creating holes or excessive reinforcement on the backside of the joint. Burn-through can weaken the weld and cause distortion or leakage. It can be caused by excessive heat input, high welding current, thin base metal, or improper electrode angle. To avoid burn-through, it is necessary to use a lower heat input and current, select a thicker base metal or use a backing plate, and hold the electrode at a low angle to the joint.

- **Overlap:** This is when the weld metal extends beyond the toe of the weld, creating an irregular shape and reducing the contact area between the weld and the base metal. Overlap can reduce the strength and appearance of the weld. It can be caused by low welding speed, high welding current, large electrode size, or incorrect electrode angle. To prevent overlap, it is important to increase the welding speed, reduce the welding current, choose a smaller electrode size, and hold the electrode at a right angle to the joint.
- **Craters:** These are depressions that form at the end of the weld when the arc is terminated abruptly. Craters can create stress concentrations and cracks in the weld. Craters can be avoided by gradually reducing the welding current at the end of the weld, filling the crater with filler metal, or using a crater-fill function on the welding machine.

BRAZING AND SOLDERING

Soldering and brazing can be used to join metals that are difficult to weld together, such as copper, brass, aluminum, and stainless steel. In this section, we will explain what soldering and brazing are, how they differ from each other, and what are their benefits and challenges.

Soldering is a joining process that uses a filler metal, called solder, to join two base metals together at temperatures below 840°F (450°C). The solder melts and flows into the gap between the base metals by capillary action, creating a bond when it solidifies. Soldering is most commonly known for use in electric circuits, where it provides electrical conductivity and mechanical strength. Soldering can also be used for plumbing, jewelry making, and other applications that require low-temperature joining.

Brazing is similar to soldering, except that the filler metal, called braze, has a higher melting point above 840°F (450°C) and below the melting point of the base metals. Brazing also relies on capillary action to fill the gap between the base metals with the molten braze, forming a strong joint when it cools down. Brazing can be used for joining dissimilar metals, such as steel and copper, or metals that have high melting points, such as tungsten and molybdenum. Brazing can also produce leak-tight joints for pipes, tubes, and other fluid systems.

Both soldering and brazing have some advantages and disadvantages compared to welding. Some of the benefits of soldering and brazing are:

- They do not require high temperatures or pressures, which reduces the risk of distortion, warping, or damage to the base metals.
- They do not affect the metallurgical properties of the base metals, such as hardness, ductility, or corrosion resistance.
- They can join thin or delicate parts that would be difficult or impossible to weld.
- They can join different types of metals that have incompatible welding characteristics.

Some of the challenges of soldering and brazing are:

- They produce weaker joints than welding, which may not withstand high stresses or temperatures.
- They require careful cleaning and preparation of the surfaces to ensure good wetting and adhesion of the filler metal.
- They may introduce contaminants or impurities into the joint, which can affect its performance or reliability.
- They may require additional steps or materials, such as fluxes or protective atmospheres, to prevent oxidation or corrosion of the filler metal or the base metals.



One or more interactive elements has been excluded from this version of the text. You can view them online here: <https://uark.pressbooks.pub/mechanicaldesign/?p=583#oembed-1>



One or more interactive elements has been excluded from this version of the text. You can view them online here: <https://uark.pressbooks.pub/mechanicaldesign/?p=583#oembed-2>



One or more interactive elements has been excluded from this version of the text. You can view them online here: <https://uark.pressbooks.pub/mechanicaldesign/?p=583#oembed-3>

PART XV

MANUFACTURING - PLASTIC PROCESSES

Learning Objectives

Many consumer goods are made with plastic parts and this chapter serves only as a summary of the many manufacturing processes available. After reading this chapter:

- Describe and compare different plastic manufacturing processes
- Understand the differences in plastic materials properties and utilize tools to select the material and manufacturing process to meet design objectives.

Plastics are synthetic materials made from polymers that can be molded into various shapes and forms. There are different types of plastics, each with its own properties and applications. Designing parts for plastic manufacturing involves selecting the right type of plastic and manufacturing method to meet your design objectives for performance and quality and cost.

Where Does Plastic Come From?



One or more interactive elements has been excluded from this version of the text. You can view them online here: <https://uark.pressbooks.pub/mechanicaldesign/?p=585#oembed-1>

PLASTIC MATERIALS

Plastics are a group of organic materials that can be shaped into various forms by applying heat and pressure. They are widely used in engineering applications because of their versatility, durability, and low cost. There are two main types of plastics for engineering purposes: thermoplastics and thermosets.

Thermoplastics are plastics that can be melted and remolded repeatedly without losing their properties. They are solid at room temperature but become soft and pliable when heated. Thermoplastics are suitable for applications that require flexibility, recyclability, and resistance to corrosion. Some common thermoplastics used in engineering are:

- Polyethylene (PE): The most widely used plastic in the world, PE is a lightweight, tough, and flexible material that can be molded into various shapes. PE is used for packaging, pipes, bottles, containers, films, and toys.
- Polypropylene (PP): A similar plastic to PE, but with higher melting point, stiffness, and strength. PP is used for automotive parts, furniture, carpets, medical devices, and textiles.
- Polyvinyl Chloride (PVC): A rigid or flexible plastic that can be blended with other additives to enhance its properties. PVC is used for pipes, fittings, cables, flooring, roofing, and window frames.
- Polystyrene (PS): A hard and brittle plastic that can be expanded into foam or extruded into sheets. PS is used for insulation, packaging, cups, plates, and disposable cutlery.
- Polyethylene Terephthalate (PET): A clear and strong plastic that can be formed into fibers or bottles. PET is used for clothing, carpets, food and beverage containers, and medical implants.
- Nylon: A synthetic polymer that can be spun into fibers or molded into shapes. Nylon is used for clothing, ropes, gears, bearings, and fasteners.
- Acetal: A strong and rigid plastic that has good resistance to wear, friction, and chemicals. Acetal is used for gears, bearings, valves, pumps, and electrical components.
- Polycarbonate (PC): A transparent and impact-resistant plastic that can withstand high temperatures and UV rays. PC is used for lenses, helmets, shields, lighting fixtures, and CDs.

Thermosets are plastics that undergo a chemical reaction during processing that makes them hard and infusible. They cannot be melted or remolded once they are cured. Thermosets are suitable for applications that require high strength, stability, and resistance to heat and chemicals. Some common thermosets used in engineering are:

- Phenolic: A dark-colored plastic that is made from phenol and formaldehyde. Phenolic is used for

electrical insulation, laminates, adhesives, and brake pads.

- Urea-formaldehydes: A white-colored plastic that is made from urea and formaldehyde. Urea-formaldehydes are used for adhesives, coatings, molding compounds, and particle boards.
- Epoxides: A plastic that is made from epoxy resin and a hardener. Epoxides are used for adhesives, coatings, composites, and electronic components.
- Polyester: A plastic that is made from polyester resin and a catalyst. Polyester is used for fiberglass reinforced plastics (FRP), boat hulls, tanks, pipes, and roofing materials.

Selecting the “Right” Plastic Material

The two things that drive the choice of plastic material for a part are 1) the desired material properties, and 2) the feasibility of manufacturing.

To start, decide on the range of properties you want and select a subset of material types that will satisfy. Consider the potential negative aspects of those properties as well. For example, resistance to chemical wear and potential for degradation in sunlight. Plastic suppliers have property tables that can help you narrow down your selection.

Try it yourself and explore the table here: [Plastic Material Properties Table | Sort & Compare | Curbell Plastics](#)

Not all manufacturing processes are possible (or commonly available) with all types of plastics. You may be limited by the manufacturing equipment you have available. This can further restrict the type of plastic you select. You can find tables in the Machinist Handbook and similar resources to find manufacturing methods and the common types of plastics available.

Look through the list of manufacturing methods and applicable plastic here: [Guide to Manufacturing Processes for Plastics | Formlabs](#)

MOLDING

Injection Molding

Plastic injection molding is a manufacturing process that involves heating plastic to a molten state and then using pressure to inject a controlled amount of it into a cold mold. The mold is usually made of metal and has cavities that correspond to the shape and size of the desired product. The plastic fills the cavities and solidifies as it cools down, forming the final product.

One of the common components of a plastic injection molding machine is a screw mechanism and a hopper. The screw mechanism rotates and pushes the plastic pellets from the hopper into a heated barrel, where they melt and become viscous. The screw mechanism also acts as a plunger that injects the melted plastic into the mold through a nozzle. When the part cools, the mold is separated and ejector pins push out the part. Most commonly, gravity is used to drop the formed part into the desired location. Designing the molds for injection molding requires that the designer consider where ejection pins will press on the part to eject it from the mold. You can often identify that a part has been manufactured using injection molding by the round marks left by the ejection pins.

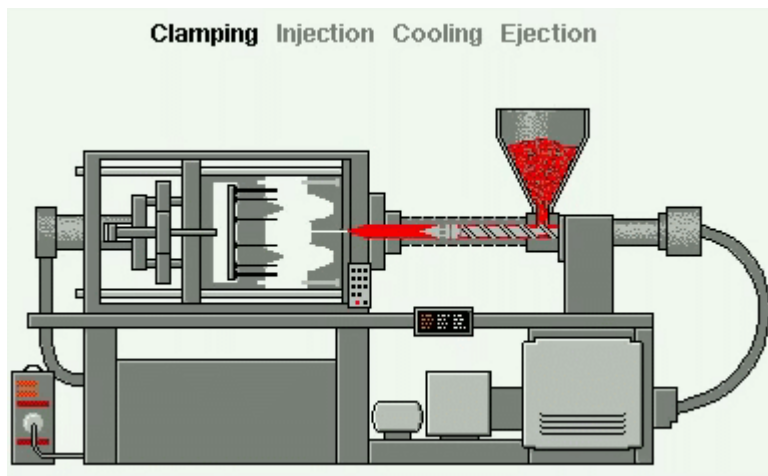

Injection Molding
Process

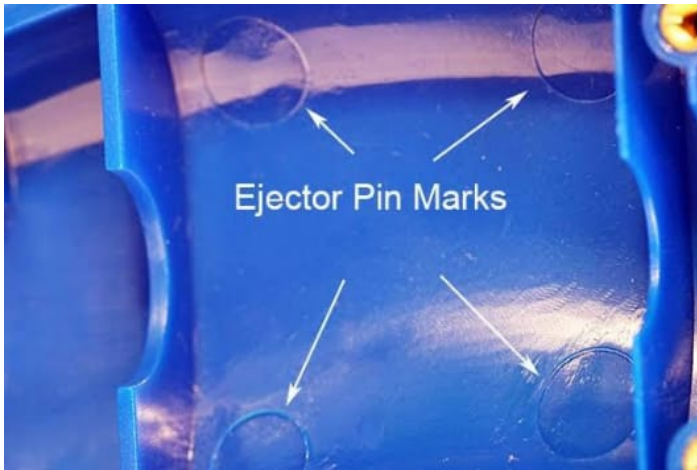

Ejector pin marks on a plastic housing part.

Plastic injection molding machines are classified by two main parameters: the shot size and the clamping tonnage. The shot size refers to the maximum amount of plastic that can be injected in one cycle, measured in grams or ounces. The clamping tonnage refers to the force that the machine can apply to keep the mold closed during the injection process, measured in tons or kilonewtons. Larger machines can produce more than 200 tons of clamping force and inject more than 20 ounces of plastic per shot.

Different types of plastic have different properties and characteristics that affect the injection molding process. One of these properties is the clamping tonnage requirement, which is the minimum force needed to prevent the mold from opening due to the internal pressure of the injected plastic. A typical value for this property is 2.5 tons per square inch of projected part area, but it can vary depending on the type and grade of plastic used.

One of the advantages of plastic injection molding is that it can produce large quantities of identical parts with high precision and accuracy. However, one of the drawbacks is that it requires a high initial investment in designing and making the mold, which can be complex and costly. Therefore, plastic injection molding is usually suitable for mass production or large-scale projects that can justify the mold cost.



One or more interactive elements has been excluded from this version of the text. You can view them online here: <https://uark.pressbooks.pub/mechanicaldesign/?p=589#oembed-1>

Blow Molding

Blow molding produces hollow parts with a thin, relatively constant thickness shell. The process involves

inflating a heated plastic tube, called a parison, inside a mold cavity until it conforms to the shape of the mold. There are two main types of blow molding: extrusion blow molding and injection blow molding.

Extrusion blow molding is the most common and versatile method of blow molding. It involves extruding a continuous parison from a die head and then clamping it between two mold halves. A blow pin is inserted into the parison and air is blown through it, expanding the parison against the mold walls. The mold is then opened and the part is ejected.

Injection blow molding is a more complex and precise method of blow molding. It involves injecting molten plastic into a preform mold, which forms the neck and base of the part. The preform is then transferred to a blow mold, where air is blown through the neck, inflating the preform into the final shape. The mold is then opened and the part is ejected.

Some examples of products made by blow molding are bottles, containers, toys, ducts, fuel tanks, and balls. Blow molded parts can be identified by the crease or seam that is formed when the mold halves separate, unless it is removed in a secondary process such as trimming or sanding.

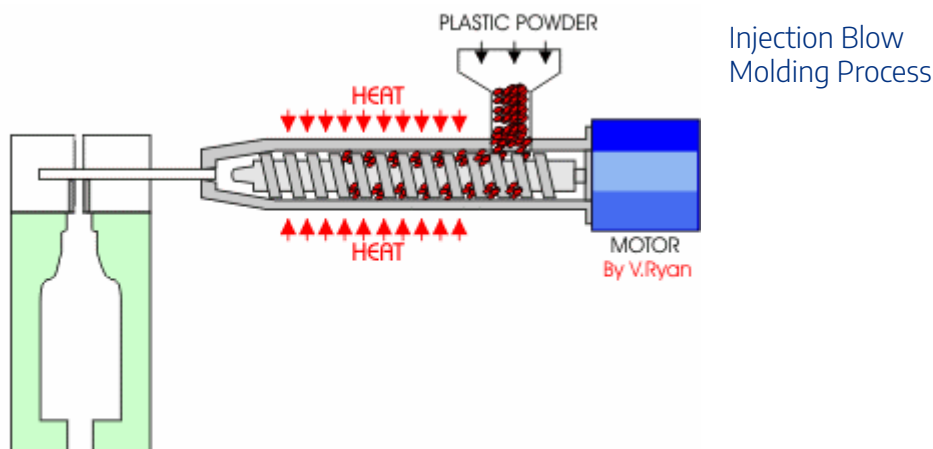

One or more interactive elements has been excluded from this version of the text. You can view them online here: <https://uark.pressbooks.pub/mechanicaldesign/?p=589#oembed-2>

Thermoforming

Thermoforming is a process of shaping a thin sheet of plastic using mechanical tools or air pressure to make it conform to the shape of a mold. The plastic sheet is heated until it becomes soft and pliable, then it is pressed against the mold by a force or a vacuum. The plastic cools down and hardens, retaining the shape of the mold.

Vacuum forming is a type of thermoforming that uses a vacuum to suck the air out between the plastic sheet and the mold. This creates a tight fit and a smooth surface on the plastic part. Vacuum forming is suitable for making large, simple and low-cost parts, such as packaging trays, containers and lids.

Advantages of thermoforming:

- It is a fast and economical method of producing plastic parts.
- It can produce parts with complex shapes and details, such as logos, textures and holes.
- It can use a variety of plastic materials, such as acrylic, polystyrene, polyethylene and PVC.
- It can produce parts with different colors, finishes and thicknesses.
- It can recycle the excess plastic material, reducing waste and cost.

Disadvantages of thermoforming:

- It requires a high initial investment in molds and equipment.
- It has a limited range of part sizes and shapes, depending on the mold design and the plastic sheet size.
- It has a lower dimensional accuracy and stability than other molding methods, such as injection molding or blow molding.
- It may produce defects such as warping, cracking, bubbles and thinning on the plastic parts.



One or more interactive elements has been excluded from this version of the text. You can view them online here: <https://uark.pressbooks.pub/mechanicaldesign/?p=589#oembed-3>

Rotational Molding

Rotational plastic molding is a process that produces hollow plastic parts by heating and rotating a mold filled with plastic resin powder. The rotation causes the plastic to melt and coat the inside of the mold evenly,

forming a uniform wall thickness. The mold continues to rotate until the plastic cools and solidifies, creating the final shape. Rotational plastic molding can be used for various types of parts or products, such as tanks, containers, bins, toys, furniture, automotive components, and more. Rotational plastic molding has several advantages, such as low mold cost, design flexibility, high durability, and minimal waste.



One or more interactive elements has been excluded from this version of the text. You can view them online here: <https://uark.pressbooks.pub/mechanicaldesign/?p=589#oembed-4>

PLASTIC EXTRUSION

Plastic extrusion is a high-volume manufacturing process that yields continuous products with uniform cross-sections. This technique involves melting thermoplastic materials and pressurizing them to force the melt through a die. A rotating screw's interaction with the barrel walls generates pressure. The die shapes the polymer into a profile that hardens during cooling. Extrusion produces items such as sheet, film, profile, pipe, and wire coating.

The plastic extrusion process begins with filling the hopper with plastic granules, which are often mixed with additives such as colorants and UV inhibitors. The feed throat transfers the granules to the barrel, where they are gradually heated by heaters and friction. The temperature of the barrel varies along its length, with higher temperatures near the die. The screw pushes the molten plastic through the feed pipe and into the die, which has a specific cross-sectional shape.

The extruded profile exits the die and enters a cooling system, which can be air, water, or a combination of both. The cooling system solidifies the profile and maintains its shape. The profile is then cut to the desired length or coiled for further processing. Extrusion shrinkage occurs when the profile contracts as it cools down, which must be accounted for in die design.

Different types of plastic have different properties and melting points, which affect their suitability for extrusion. Some common plastics used for extrusion are polyethylene (PE), polypropylene (PP), polyvinyl chloride (PVC), polystyrene (PS), and acrylonitrile butadiene styrene (ABS).



One or more interactive elements has been excluded from this version of the text. You can view them online here: <https://uark.pressbooks.pub/mechanicaldesign/?p=587#oembed-1>

PLASTIC 3D PRINTING AT LARGE SCALE



One or more interactive elements has been excluded from this version of the text. You can view them online here: <https://uark.pressbooks.pub/mechanicaldesign/?p=591#oembed-1>

One of the main challenges of mass production of 3D printed plastic parts is to ensure consistency and repeatability across multiple printers and batches. This can be affected by various factors, such as the temperature and humidity of the printing environment, the quality and age of the material, the calibration and maintenance of the printers, and the design of the parts.

The best practices for mass production using 3D printing technologies are the same as discussed in prototyping.

- Choosing the appropriate material and printing method for the desired function and quality of the parts.
- Designing the parts with minimal overhangs, supports, and infill to reduce printing time and material usage.
- Applying and minimize proper post-processing techniques, such as cleaning, curing, sanding, or painting, to improve the appearance and performance of the parts.
- Implementing quality control measures, such as testing, inspection, or feedback loops, to monitor and correct any deviations or defects in the parts.
- Optimizing the layout and orientation of the parts on the printing platform to maximize the utilization of space and minimize the need for manual intervention.

MACHINING

Machining plastic parts is different from machining metal parts in several ways. Plastic parts are more prone to deformation, melting, and cracking due to the heat and stress generated by the cutting tools. Therefore, some design considerations are necessary to ensure the quality and accuracy of the machined plastic parts.

Design considerations for machining plastic parts:

- Choosing the right type of plastic material for the desired properties and machinability. Some plastics are easier to machine than others, such as acetal, nylon, and polycarbonate. Other plastics, such as polyethylene, polypropylene, and PVC, are more difficult to machine due to their low melting point and high ductility.
- Selecting the appropriate cutting tools for the plastic material and the geometry of the part. The cutting tools should have sharp edges, high rake angles, and large relief angles to reduce friction and heat. The cutting speed, feed rate, and depth of cut should also be optimized to avoid excessive heat and stress on the plastic part.
- Providing adequate cooling and lubrication during the machining process. Cooling and lubrication can help reduce the heat and friction generated by the cutting tools, prevent melting and deformation of the plastic part, and improve the surface finish and dimensional accuracy. Water-based coolants or compressed air are commonly used for cooling and lubrication of plastic parts.
- Designing the part with sufficient wall thickness, corner radius, and tolerance to avoid cracking, chipping, or warping of the plastic part. Thin walls, sharp corners, and tight tolerances can increase the stress and strain on the plastic part during machining, leading to defects and failures. A minimum wall thickness of 0.5 mm, a corner radius of 0.25 mm, and a tolerance of 0.1 mm are recommended for machined plastic parts.



One or more interactive elements has been excluded from this version of the text. You can view them online here: <https://uark.pressbooks.pub/mechanicaldesign/?p=833#oembed-1>

DESIGN FOR PLASTIC MANUFACTURING

Qualitative Best Practices

- Choose a material that is suitable for the intended function, performance, and appearance of the part. Consider the properties of the material such as strength, stiffness, toughness, thermal stability, chemical resistance, color, and recyclability.
- Minimize the number of parts and features in the design. Simplify the part geometry and avoid unnecessary details such as sharp corners, undercuts, thin walls, and deep cavities. This will reduce the mold complexity and improve the quality and consistency of the part.
- Design the part with uniform wall thickness and avoid abrupt changes in cross-sections. This will prevent defects such as warping, sink marks, and stress concentration in the part. Use ribs, gussets, and bosses to reinforce the part and provide attachment points.
 - Design the part with adequate draft angles and smooth surfaces. This will facilitate the ejection of the part from the mold and reduce the friction and wear on the mold. Use textures or patterns to hide minor defects or scratches on the part surface.
 - Design the part with proper gate location and size. The gate is the point where the molten plastic enters the mold cavity. The gate location and size affect the flow pattern, filling time, pressure, and temperature of the plastic in the mold. The gate should be placed in a less visible area of the part and should be large enough to allow sufficient flow of plastic without causing excessive shear stress or jetting.
 - Design the part with proper venting and cooling channels. Venting allows air and gases to escape from the mold cavity during injection. Cooling channels circulate water or other fluids around the mold to control the temperature of the plastic in the mold. Venting and cooling affect the cycle time, shrinkage, warpage, and dimensional accuracy of the part.

Plastic part manufacturers are a great resource to find more guidelines and specific expert support for plastic part manufacturing.

For example, see: [8 Factors in Plastic Part Design for Manufacturability \(nicoletplastics.com\)](http://nicoletplastics.com)

Deep Dive into Specific DFM for Plastic Methods



One or more interactive elements has been excluded from this version of the text. You can view them online here: <https://uark.pressbooks.pub/mechanicaldesign/?p=593#oembed-1>

Section Questions:



*An interactive H5P element has been excluded from this version of the text. You can view it online here:
<https://uark.pressbooks.pub/mechanicaldesign/?p=593#h5p-16>*

PART XVI

TAKING THE NEXT STEPS

Final Thoughts

As we wrap up this text on product design and manufacturing there are a few important items to cover in terms of “taking the next steps.”

First, the goal of this text is to cover concepts and tools to develop product concepts to the point where they are mature enough to explore developing manufacturing prototypes. That is, this book covers content from opportunity identification, concept development, and building and testing prototypes of designs that can be manufactured. However, there is still a long way to go for a product to appear online or on a store shelf. Manufacturing engineering, tooling design, production and industrial management, sales, distribution, etc. No book or course can cover all of these. Instead, it is helpful to consider what is next for the product concept and design you have been working on and what is next for you in your education and professional development.

This last part covers the wrap up of the conceptual design process with documentation and some starting information on preliminary patent applications. Additionally, if product design is something that interests you, we have a few resources that can help define what you might want to pursue to give you an advantage in this area of engineering.

PRELIMINARY PATENT APPLICATIONS

Preliminary Patents in the USA

A provisional patent application is a type of patent application that can be filed with the United States Patent and Trademark Office (USPTO) or similar country authority to secure an early filing date for an invention. It is a low-cost and simplified way to establish the priority of an invention without having to file a formal patent claim, oath or declaration, or any information disclosure statement. A provisional patent application also allows the inventor to use the term “patent pending” in connection with the description of the invention.

A provisional patent application has a duration of 12 months from the date it is filed. During this period, the inventor can test, refine, and market the invention to determine its commercial viability. However, to obtain patent protection beyond the 12-month period, the inventor must file a corresponding nonprovisional patent application that claims the benefit of the provisional patent application. The nonprovisional patent application must contain or be amended to contain a specific reference to the provisional patent application and must be filed within the 12-month pendency period of the provisional patent application or within 14 months with a grantable petition. If the inventor fails to file a nonprovisional patent application within the required time frame, the provisional patent application will expire and the inventor will lose the benefit of the earlier filing date.

A provisional patent application can be beneficial for inventors who want to secure their position as “first to file” by submitting a simplified application that does not reveal the exact details of their invention. It can also save costs by avoiding legal fees and allowing inventors to prepare their own application. However, a provisional patent application does not guarantee that a patent will be issued from it. It is only a temporary placeholder that requires a subsequent nonprovisional patent application to obtain patent protection. Therefore, inventors should carefully consider their options and consult a patent attorney before filing a provisional patent application.



One or more interactive elements has been excluded from this version of the text. You can view them online here: <https://uark.pressbooks.pub/mechanicaldesign/?p=597#oembed-1>

US Patent and Trademark Office

Read through the USPTO's instructions on filing for a provisional patent:

[Provisional Application for Patent | USPTO](#)

European Patent Office

You can also see what the process looks like using the European Patent Office. Many large companies that plan to have an international market will file in the applicable country's patent office.

[How to apply for a patent | Epo.org](#)

PROFESSIONAL LICENSURE AND CONSULTING

An engineering student who wants to become a licensed professional engineer (PE) needs to pass two exams: the **Fundamentals of Engineering** (FE) exam and the **Principles and Practice of Engineering** (PE) exam. The FE exam is typically taken during the final year of an undergraduate engineering program or shortly after graduation. It is a computer-based exam that covers the basic knowledge and skills required for entry-level engineering work. The PE exam is taken after gaining at least four years of work experience under the supervision of a PE. It tests the ability to apply engineering principles and practices to solve complex problems in a specific discipline.

The benefits of passing both exams are significant. A PE license demonstrates competence, credibility, and ethical standards in the engineering profession. It also opens up more career opportunities, higher salaries, and greater responsibilities. A PE license is required for engineers who offer their services to the public, sign and seal engineering documents, or work as consultants or independent contractors. A PE license is also a valuable asset for engineers who work in government agencies, private firms, or academia.



One or more interactive elements has been excluded from this version of the text. You can view them online here: <https://uark.pressbooks.pub/mechanicaldesign/?p=601#oembed-1>

Working as a Design Engineer

Watch the video interviews below for a real sense of the product design experience from a mechanical engineering perspective.



One or more interactive elements has been excluded from this version of the text. You can view them online here: <https://uark.pressbooks.pub/mechanicaldesign/?p=601#oembed-2>



One or more interactive elements has been excluded from this version of the text. You can view them online here: <https://uark.pressbooks.pub/mechanicaldesign/?p=601#oembed-3>

FINAL THOUGHTS

This concludes our textbook on becoming a mechanical product designer and the mechanical design process. We hope you have learned a lot from this book and that you will apply your knowledge and skills to create innovative and sustainable solutions for real-world problems. Mechanical product design is a dynamic and rewarding field that requires constant learning and improvement. We encourage you to keep exploring new ideas, technologies, and methods to enhance your professional development and career prospects. We wish you all the best on the rest of your lifelong learning adventure.

Section Questions:



An interactive H5P element has been excluded from this version of the text. You can view it online here:

<https://uark.pressbooks.pub/mechanicaldesign/?p=881#h5p-17>